



RICOH COMPANY, LTD.

15-5, Minami Aoyama 1-chome,
Minato-ku, Tokyo 107-8544, Japan
Phone: +81-(0)3-3479-3111



RICOH LASER AP2610/AP2610N

Setup Guide

RICOH LASER AP2610/AP2610N Setup Guide

RICOH LASER AP2610/AP2610N Setup Guide

Overseas Affiliates

U.S.A.

RICOH CORPORATION
5 Dedrick Place
West Caldwell, New Jersey 07006
Phone: +1-973-882-2000

The Netherlands

RICOH EUROPE B.V.
Groenelaan 3, 1186 AA, Amstelveen
Phone: +31-(0)20-5474111

United Kingdom

RICOH UK LTD.
RicoH House,
1 Plane Tree Crescent, Feltham,
Middlesex, TW13 7HG
Phone: +44-(0)20-8261-4000

Germany

RICOH DEUTSCHLAND GmbH
Mergenthalerallee 38-40,
65760 Eschborn
Phone: +49-(0)6196-9060

France

RICOH FRANCE S.A.
383, Avenue du Général de Gaulle
BP 307-92143 Clamart Cedex
Phone: +33-(0)-821-01-74-26

Spain

RICOH ESPAÑA S.A.
Avda. Litoral Mar, 12-14,
08005 Barcelona
Phone: +34-(0)93-295-7600

Italy

RICOH ITALIA SpA
Via della Metallurgia 12,
37139 Verona
Phone: +39-045-8181500

Hong Kong

RICOH HONG KONG LTD.
21/F., Tai Yau Building,
181, Johnston Road,
Wan Chai, Hong Kong
Phone: +852-2862-2888

Singapore

RICOH ASIA PACIFIC PTE.LTD.
260 Orchard Road,
#15-01/02 The Heeren,
Singapore 238855
Phone: +65-830-5888

Model number: RICOH LASER AP2610, RICOH LASER AP2610N

Printed in China

UE (USA) G074-8617

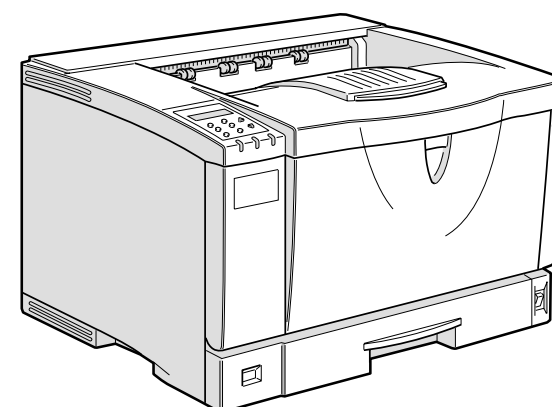

For safety, please read this manual carefully before you use this product and keep it handy for future reference.

Introduction

This manual contains detailed instructions on the operation and maintenance of this machine. To get maximum versatility from this machine all operators should carefully read and follow the instructions in this manual. Please keep this manual in a handy place near the machine.

Please read "Safety Information" in this manual before using this machine. It contains important information related to USER SAFETY and PREVENTING EQUIPMENT PROBLEMS.

Power Source

120 V, 60 Hz, 8.4 A or more

Please be sure to connect the power cable to a power source as shown above.

Operator Safety:

This machine is considered a CDRH class I laser device, safe for office/EDP use. The machine contains 7 milliwatt, 645 - 660 nanometer wavelength, AlGaInp Laser Diode. Direct (or indirect reflected) eye contact with the laser beam might cause serious eye damage. Safety precautions and interlock mechanisms have been designed to prevent any possible laser beam exposure to the operator.

Laser Safety:

The Center for Devices and Radiological Health (CDRH) prohibits the repair of laser-based optical unit in the field. The optical housing unit can only be repaired in a factory or at a location with the requisite equipment. The laser subsystem is replaceable in the field by a qualified Customer Engineer. The laser chassis is not repairable in the field. Customer engineers are therefore directed to return all chassis and laser subsystems to the factory or service depot when replacement or the optical subsystem is required.

Important

Contents of this manual are subject to change without prior notice. In no event will the company be liable for direct, indirect, special, incidental, or consequential damages as a result of handling or operating the machine.

Caution:

Use of controls or adjustment or performance of procedures other than those specified in this manual might result in hazardous radiation exposure.

Do not attempt any maintenance or troubleshooting other than that mentioned in this manual. This printer contains a laser beam generator and direct exposure to laser beams can cause permanent eye damage.

Two kinds of size notation are employed in this manual. With this machine refer to the inch version.

For good print quality, the supplier recommends that you use genuine toner from the supplier.

The supplier shall not be responsible for any damage or expense that might result from the use of parts other than genuine parts from the supplier with your office products.

Notes to users in the United States of America

Notice:

This equipment has been tested and found to comply with the limits for a Class B digital device, pursuant to Part 15 of the FCC Rules. These limits are designed to provide reasonable protection against harmful interference in a residential installation. This equipment generates, uses and can radiate radio frequency energy and, if not installed and used in accordance with the instructions, may cause harmful interference to radio communications.

However, there is no guarantee that interference will not occur in a particular installation. If this equipment does cause harmful interference to radio or television reception, which can be determined by turning the equipment off and on, the user is encouraged to try to correct the interference by one more of the following measures:

Reorient or relocate the receiving antenna.

Increase the separation between the equipment and receiver.

Connect the equipment into an outlet on a circuit different from that to which the receiver is connected.

Consult the dealer or an experienced radio/TV technician for help.

Warning

Changes or modifications not expressly approved by the party responsible for compliance could void the user's authority to operate the equipment.

Caution (in case of 100BaseTX environment):

Properly shielded cables must be used for connections to host computer (and/or peripheral) in order to meet FCC emission limits.

Network interface cable with ferrite core must be used for RF interference suppression.

Declaration of Conformity

Product Name: Laser Printer

Model Number: RICOH LASER AP2610/RICOH LASER AP2610N

Responsible party: Ricoh Corporation

Address: 5 Dedrick Place, West Caldwell, NJ 07006

Telephone number: 973-882-2000

This device complies with part 15 of FCC Rules.

Operation is subject to the following two conditions:

1. This device may not cause harmful interference, and
2. this device must accept any interference received, including interference that may cause undesired operation.

Properly shielded cables must be used for connections to host computer (and/or peripheral) in order to meet FCC emission limits.

Network interface cable with ferrite core must be used for RF interference suppression.

Note to users in Canada

Note:

This Class B digital apparatus complies with Canadian ICES-003.

802.11b Interface Unit TypeA(R-WL11):

This device complies with RSS 210 of Industry Canada.

To prevent radio interference to the licensed service, this device must be operated indoors only and should be kept away from windows to provide maximum shielding.

Remarque concernant les utilisateurs au Canada

Avertissement:

Cet appareil numérique de la classe B est conforme à la norme NMB-003 du Canada.

802.11b Interface Unit TypeA(R-WL11):

Pour empêcher que cet appareil cause du brouillage au service faisant l'objet d'une licence, il doit être utilisé à l'intérieur et devrait être placé loin des fenêtres afin de fournir un écran de blindage maximal. Si le matériel (ou son antenne d'émission) est installé à l'extérieur, il doit faire l'objet d'une licence.

In accordance with IEC 60417, this machine uses the following symbols for the main power switch:

I means POWER ON.

O means POWER OFF.

Setup Guide

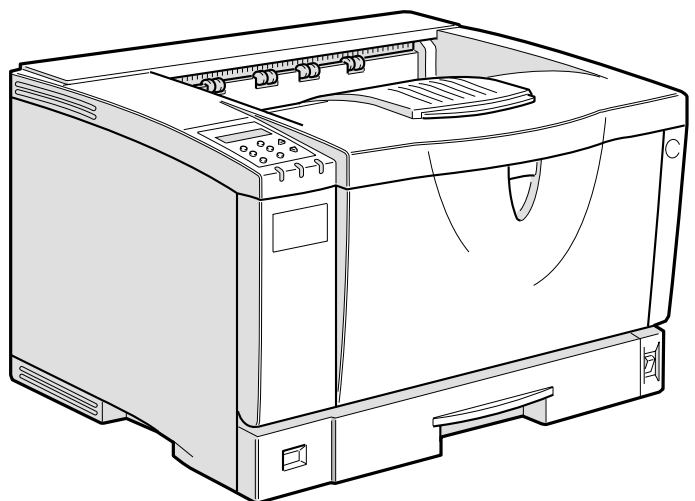

For safety, please read this manual carefully before you use this product and keep it handy for future reference.

Introduction

This manual contains detailed instructions on the operation and maintenance of this machine. To get maximum versatility from this machine all operators should carefully read and follow the instructions in this manual. Please keep this manual in a handy place near the machine.

Please read "Safety Information" in this manual before using this machine. It contains important information related to USER SAFETY and PREVENTING EQUIPMENT PROBLEMS.

Power Source

120 V, 60 Hz, 8.4 A or more

Please be sure to connect the power cable to a power source as shown above.

Operator Safety:

This machine is considered a CDRH class I laser device, safe for office/EDP use. The machine contains 7 milliwatt, 645 - 660 nanometer wavelength, AlGaInp Laser Diode. Direct (or indirect reflected) eye contact with the laser beam might cause serious eye damage. Safety precautions and interlock mechanisms have been designed to prevent any possible laser beam exposure to the operator.

Laser Safety:

The Center for Devices and Radiological Health (CDRH) prohibits the repair of laser-based optical unit in the field. The optical housing unit can only be repaired in a factory or at a location with the requisite equipment. The laser subsystem is replaceable in the field by a qualified Customer Engineer. The laser chassis is not repairable in the field. Customer engineers are therefore directed to return all chassis and laser subsystems to the factory or service depot when replacement or the optical subsystem is required.

Important

Contents of this manual are subject to change without prior notice. In no event will the company be liable for direct, indirect, special, incidental, or consequential damages as a result of handling or operating the machine.

Caution:

Use of controls or adjustment or performance of procedures other than those specified in this manual might result in hazardous radiation exposure.

Do not attempt any maintenance or troubleshooting other than that mentioned in this manual. This printer contains a laser beam generator and direct exposure to laser beams can cause permanent eye damage.

Two kinds of size notation are employed in this manual. With this machine refer to the inch version.

For good print quality, the supplier recommends that you use genuine toner from the supplier.

The supplier shall not be responsible for any damage or expense that might result from the use of parts other than genuine parts from the supplier with your office products.

Trademarks

Microsoft, Windows and Windows NT are registered trademarks of Microsoft Corporation in the United States and/or other countries.

Novell, Netware, NDS are registered trademarks of Novell, Inc.

PostScript is a registered trademark of Adobe Systems, Incorporated.

PCL is a registered trademark of Hewlett-Packard Company.

AppleTalk, Apple, Macintosh, TrueType and LaserWriter are registered trademarks of Apple Computer, Incorporated.

IPS-PRINT Printer Language Emulation Copyright© 1999-2000 Oak Technology, Inc., All rights reserved.

Ethernet is a registered trademark of Xerox Corporation.

Other product names used herein are for identification purposes only and might be trademarks of their respective companies. We disclaim any and all rights in those marks.

- The product name of Windows[®] 95 is Microsoft[®] Windows[®] 95.
- The product name of Windows[®] 98 is Microsoft[®] Windows[®] 98.
- The product name of Windows[®] Me is Microsoft[®] Windows[®] Millennium Edition (Windows Me).
- The product names of Windows[®] 2000 are as follows:
 - Microsoft[®] Windows[®] 2000 Advanced Server
 - Microsoft[®] Windows[®] 2000 Server
 - Microsoft[®] Windows[®] 2000 Professional
- The product names of Windows[®] XP are as follows:
 - Microsoft[®] Windows[®] XP Professional
 - Microsoft[®] Windows[®] XP Home Edition
- The product names of Windows NT[®] 4.0 are as follows:
 - Microsoft[®] Windows NT[®] Server 4.0
 - Microsoft[®] Windows NT[®] Workstation 4.0

Notes:

Some illustrations in this manual might be slightly different from the machine. Certain options might not be available in some countries. For details, please contact your local dealer.

Safety Information

When using your printer, the following safety precautions should always be followed.

Safety During Operation

In this manual, the following important symbols are used:

⚠ WARNING:
Indicates a potentially hazardous situation which, if instructions are not followed, could result in death or serious injury.

⚠ CAUTION:
Indicates a potentially hazardous situation which, if instructions are not followed, may result in minor or moderate injury or damage to property.

⚠ WARNING:

- **Connect the power cord directly into a wall outlet and never use an extension cord.**
- **Disconnect the power plug (by pulling the plug, not the cable) if the power cable or plug becomes frayed or otherwise damaged.**
- **To avoid hazardous electric shock or laser radiation exposure, do not remove any covers or screws other than those specified in this manual.**
- **Turn off the power and disconnect the power plug (by pulling the plug, not the cable) if any of the following occurs:**
 - **You spill something into the machine.**
 - **You suspect that your machine needs service or repair.**
 - **The external housing of your machine has been damaged.**
- **Do not incinerate spilled toner or used toner. Toner dust might ignite when exposed to an open flame.**
- **Disposal can take place at our authorized dealer.**
- **Dispose of the used toner cartridge in accordance with the local regulations.**

⚠ CAUTION:

- *Protect the machine from dampness or wet weather, such as rain and snow.*
- *Unplug the power cord from the wall outlet before you move the machine. While moving the machine, you should take care that the power cord will not be damaged under the machine. Unplug the power cord from the wall outlet before you move the machine. While moving the machine, you should take care that the power cord will not be damaged under the machine.*
- *When you disconnect the power plug from the wall outlet, always pull the plug (not the cable).*
- *Do not allow paper clips, staples, or other small metallic objects to fall inside the machine.*
- *Keep toner (used or unused) and toner cartridge out of the reach of children.*
- *For environmental reasons, do not dispose of the machine or expended supply waste at household waste collection points. Disposal can take place at an authorized dealer.*
- *The inside of the machine could be very hot. Do not touch the parts with a label indicating "⚠" (means hot surface). Touching "⚠" (means hot surface) could result in a burn.*
- *Our products are engineered to meet high standards of quality and functionality, and we recommend that you use only the expendable supplies available at an authorized dealer.*

Positions of Labels and Hallmarks for ⚠WARNING and ⚠CAUTION

This machine has labels and hallmarks for ⚠WARNING, ⚠CAUTION at the positions shown below. For safety, please follow the instructions and handle the machine as indicated.

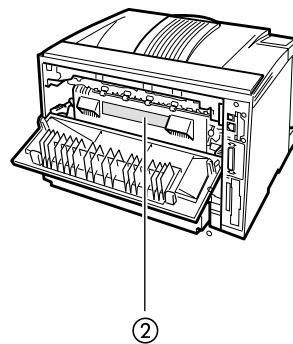
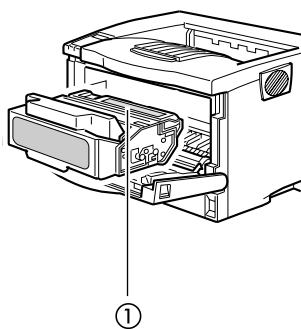

ZGDH250E

①

 <p>WARNING ATTENTION WARNUNG AVVISO AVISO ADVERTENCIA 警告</p>	 <ul style="list-style-type: none"> ● Do not incinerate toner or toner containers. Toner dust may cause flashback when exposed to an open flame. ● Ne pas incinérer les cartouches ni les boîtes de cartouches de toner. Exposée à une flamme nue, la cendre de toner peut provoquer un retour de flamme. ● Verbrennen Sie keinen Toner oder Tonerkartusche. Tonerstaub kann beim kontakt mit offenem Feuer explodieren. ● Non gettare il toner o i contenitori del toner sul fuoco. La polvere del toner si può incendiare dalla fiamma. ● No incinere el tóner ni los contenedores de tóner. El polvo de tóner puede inflamarse al ser expuesto al fuego. ● Não exponha o Toner ou a sua embalagem ao fogo. O pó de Toner poderá explodir quando exposto a chama viva. ● トナー又はトナーの入った容器を直接焼却等の火中に投入しないでください。火傷をするおそれがあります。
--	--

②

 <p>CAUTION PRECAUCIÓN ACHTUNG ATTENZIONE ATTENTION 高温注意</p>	 <ul style="list-style-type: none"> ●High temperature. ●Alta temperatura.  <ul style="list-style-type: none"> ●Hohe Temperatur. ●Temperatura elevata. ●Temperature leve. ●高温になっています。
--	--

ENERGY STAR Program

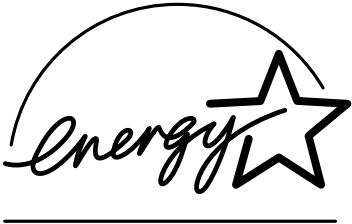
	<p>As an ENERGY STAR Partner, we have determined that this machine model meets the ENERGY STAR Guidelines for energy efficiency.</p>
---	--

The ENERGY STAR Guidelines intend to establish an international energy-saving system for developing and introducing energy-efficient office equipment to deal with environmental issues, such as global warming.

When a product meets the ENERGY STAR Guidelines for energy efficiency, the Partner shall place the ENERGY STAR logo onto the machine model.

This product was designed to reduce the environmental impact associated with office equipment by means of energy-saving features, such as Low-power mode.

- **Energy Saver mode**

This printer automatically lowers its power consumption 30 minutes after the last operation has been completed. To exit Energy Saver mode, press any key on the control panel. To change the setting of the Energy Saver mode, see “System Menu” in the Printer Reference on the CD-ROM labeled “Printer Drivers and Utilities”.

- ❖ **Specifications**

Energy Saver mode	Power Consumption	<ul style="list-style-type: none"> • Basic model: With Options: 17 W or less Printer Only: 12 W • Network standard model: With Options: 18 W or less Printer Only: 13 W
	Default Time	30 minutes

.....

- 💡 **Recycled Paper**

In accordance with the ENERGY STAR Program, we recommend use of recycled paper which is environment friendly. Please contact your sales representative for recommended paper.

.....

Manuals for This Printer

Manuals for This Printer

The following manuals describe the operational procedures and maintenance of this machine.

To enhance safe and efficient operation of this printer, all users should read and follow the instructions carefully.

❖ **Quick Installation Guide**

Describes how to install the printer.

❖ **Setup Guide (this manual)**

Provides information about setting up the printer and its options. This manual is provided as a printed manual, and also on the CD-ROM labeled "Operating Instructions".

❖ **Printer Reference**

Provides information about using the printer and its options. This manual is provided on the CD-ROM labeled "Operating Instructions".

❖ **Network Printing Guide**

Provides information about setting up and using the printer in a network environment. This manual is provided on the CD-ROM labeled "Operating Instructions".

❖ **PostScript 3 Operating Instructions Supplement**

Describes the menus and features for the PostScript 3 printer driver. This manual is provided on the CD-ROM labeled "Operating Instructions".

 **Note**

- ❑ There are three CD-ROMs that come with this printer. "Operating Instructions", "Printer Drivers and Utilities", and "Document Management Utility".
- ❑ Concerning UNIX information, please visit our Web site or consult your authorized reseller.

How to Read This Manual

Symbols

In this manual, the following symbols are used:

 **WARNING:**

This symbol indicates a potentially hazardous situation which, if instructions are not followed, could result in death or serious injury.

 **CAUTION:**

This symbol indicates a potentially hazardous situation which, if instructions are not followed, may result in minor or moderate injury or damage to property.

* The statements above are notes for your safety.

 **Important**

If this instruction is not followed, paper might be misfed, originals might be damaged, or data might be lost. Be sure to read this.

 **Preparation**

This symbol indicates the prior knowledge or preparations required before operating.

 **Note**

This symbol indicates precautions for operation, or actions to take after misoperation.

 **Limitation**

This symbol indicates numerical limits, functions that cannot be used together, or conditions in which a particular function cannot be used.

 **Reference**

This symbol indicates a reference.

[]

Keys that appear on the machine's panel display.

Keys and buttons that appear on the computer's display.

[]

Keys built into the machine's control panel.

Keys on the computer's keyboard.

TABLE OF CONTENTS

1. Getting Started

Features of This Printer	1
Printer Drivers for This Printer.....	2
Software and Utilities Included on the CD-ROM.....	4
Viewing the Contents of the CD-ROM	5
Guide to This Printer	6
Mainframe	6
Control Panel	9

2. Installing Options

Available Options	12
Paper Feed Unit Type 2600.....	15
Envelope Feeder Type 2600	17
Memory Unit TypeB 64MB	18
Network Interface Board Type 2610.....	21
Installing the Network Interface Board	21
Connecting the Network Interface Cable to the Network	24
1394 Interface Unit Type 4510	25
Installing the 1394 Interface Unit.....	25
Connecting the 1394 Interface Cable to the Printer	28
802.11b Interface Unit Type A	29
Hard Disk Drive Type 2600	32
AD410 (Duplex Unit).....	34
1-bin Shift Sort Tray Type 2600.....	36
CS380 (Mailbox).....	38

3. Configuring the Printer for the Network

Ethernet Configuration	41
IEEE 1394 Configuration.....	45
IEEE 802.11b (Wireless LAN) Configuration.....	48

4. Installing the Printer Driver and Software

Installation Method	51
Quick Install	52
Installing the PCL 6/5e Printer Driver	54
Installing the PCL 6/5e Printer Driver.....	54
Setting Up Options	55
Installing the RPCS Printer Driver	56
Installing the RPCS Printer Driver.....	56
Setting Up Options	57
Installing the PostScript Printer Driver	58
Windows 95/98/Me - Installing the PostScript Printer Driver.....	58
Windows 2000/Windows XP - Installing the PostScript Printer Driver	59
Windows NT 4.0 - Installing the PostScript Printer Driver.....	61
Macintosh - Installing the PostScript 3 Printer Driver.....	64
Installing the Printer Driver Using USB	66
Windows 98/Me - Installing the Printer Driver Using USB	66
Windows 2000/Windows XP-Installing the Printer Driver Using USB	67
Macintosh-Creating a Desktop Printer icon.....	67
Installing the Printer Driver Using IEEE 1394	68
Printing with SCSI Print.....	68
Printing with IP over 1394	71
Installing the SmartNetMonitor for Client/Admin	73
Installing the Agfa Monotype Font Manager 2000	74
Using Adobe PageMaker Version 6.0 or 6.5	75
INDEX	76



1. Getting Started

Features of This Printer

This printer is designed especially for office workgroups, both for shared usage within a network environment, and for one-to-one usage by being connected directly to the computer.

❖ Time Saving

Superior features save time on print tasks.

- Continuous Printing Speed : 26 ppm.
A4 , 8 1/2" , maximum printing speed from a standard paper tray.
- All Front Operation: From the front, you can replace the toner cartridge, check indicators, and clear a paper misfeed if it occurs.





❖ Compact Body

Its compact body requires minimum space to place it on your desk or desk side.





❖ Network Connectivity

- Basic model
This is a printer with a standard USB port and parallel port.
- Network standard model
This is a printer with a standard Ethernet port, USB port, and parallel port.

❖ Major Specifications

Printing Speed	26 pages per minute (A4  , 8 1/2" )
Maximum Print Quality	True 1200 × 1200 dpi resolutions (PCL 6, RPCS, PS3)
Printer Language	PCL 6, PCL 5e, RPCS, PostScript 3
Maximum Input Paper Size	Paper Tray and Bypass Tray: A3  , 11" 
Standard Memory Size	32MB
Maximum Memory Size with Optional Memory	96MB

Note

-  The "  " symbol means short-edge feed direction.
-  The "  " symbol means long-edge feed direction.

Printer Drivers for This Printer

Printing requires installation of a printer driver for your operating system. The following drivers are included on the CD-ROM that comes with this printer.

Printer Language	PCL 6	PCL 5e	RPCS	PostScript 3
Operating system				
Windows 95 ^{*1}	√	√	√	√ ^{*9}
Windows 98 ^{*2}	√	√	√	√ ^{*9}
Windows Me ^{*3}	√	√	√	√ ^{*9}
Windows 2000 ^{*4}	√	√	√	√ ^{*9}
Windows XP ^{*5}	√	√	√	√ ^{*9}
Windows NT 4.0 ^{*6}	√	√	√	√ ^{*8 *9}
Mac OS ^{*7}				√ ^{*9}

^{*1} Microsoft Windows 95 operating system

^{*2} Microsoft Windows 98 operating system

^{*3} Microsoft Windows Millennium Edition

^{*4} Microsoft Windows 2000 Advanced Server

Microsoft Windows 2000 professional

Microsoft Windows 2000 Server

^{*5} Microsoft Windows XP Professional

Microsoft Windows XP Home Edition

^{*6} Microsoft Windows NT Server operating system version 4.0, Microsoft Windows NT Workstation operating system version 4.0 in a computer using x86 processors.

^{*7} Required version is 8.6 or later operating system.

^{*8} Requires Service Pack 4 or later.

^{*9} The Adobe PostScript printer drivers and PostScript Printer Description (PPD) files are included on the CD-ROM labeled "Operating Instructions".

❖ PCL printer drivers

Printer drivers allow the computer to communicate with the printer via a printer language. Two kinds of PCL printer drivers, PCL 6 and PCL 5e, are provided with this printer. We recommend PCL 6 as your first choice.

Note

- Some of your applications might require the installation of the PCL 5e printer driver. In this case, you can install PCL 5e in addition to PCL 6. See p.54 "Installing the PCL 6/5e Printer Driver"

❖ RPCS printer driver

This printer driver allows the computer to communicate with the printer via a printer language. The preset type user interface is provided in addition to the conventional one.

See p.56 "Installing the RPCS Printer Driver"

❖ Adobe PostScript Printer Drivers and PPD files

The Adobe Postscript printer drivers and PPD files are included on the CD-ROM that comes with this printer. Adobe PostScript printer driver allows the computer to communicate with the printer via a printer language. The PPD files allow the printer driver to enable the printer specific functions.

See p.58 "Windows 95/98/Me - Installing the PostScript Printer Driver"

See p.59 "Windows 2000/Windows XP - Installing the PostScript Printer Driver"

See p.61 "Windows NT 4.0 - Installing the PostScript Printer Driver"

Software and Utilities Included on the CD-ROM

1

There are three CD-ROMs that come with this printer. These are labeled "Operating Instructions", "Printer Drivers and Utilities" and "Document Management Utility". The following are included on the three separate CD-ROMs.

❖ **Agfa Monotype Font Manager 2000**

Helps you to install new screen fonts, or organize and manage fonts already installed on the system. This is included on the CD-ROM labeled "Printer Drivers and Utilities".

❖ **SmartNetMonitor for Admin**

A utility for the system administrator to manage printers on the network. This is included on the CD-ROM labeled "Printer Drivers and Utilities".

Reference

See SmartNetMonitor for Admin online Help for more information about using SmartNetMonitor for Admin.

❖ **SmartNetMonitor for Client**

A utility for users to manage their own print status on the network. This is included on the CD-ROM labeled "Printer Drivers and Utilities".

Reference

See SmartNetMonitor for Client online Help for more information about using SmartNetMonitor for Client.

❖ **Acrobat Reader**

A utility that allows you to read PDF (Portable Document Format). This is included on the CD-ROM labeled "Operating Instructions".

Note

- Documentation about using the printer is included on the CD-ROM in PDF format. See Acrobat Reader online Help for more information about using Acrobat Reader.

Important

- If you upgrade to Windows 2000 from Windows 95/98/Me or Windows NT 4.0, the software and utilities must be uninstalled prior to installing Windows 2000. Then reinstall them in a Windows 2000 environment.

Viewing the Contents of the CD-ROM

Follow the steps to view the contents of the CD-ROM.

- 1** Insert the CD-ROM into the CD-ROM drive.

Auto Run will start the installer.

- 2** Click [**Browse This CD-ROM**].

Explorer starts and displays the contents of the CD-ROM.

Guide to This Printer

1

Mainframe

◆ Exterior

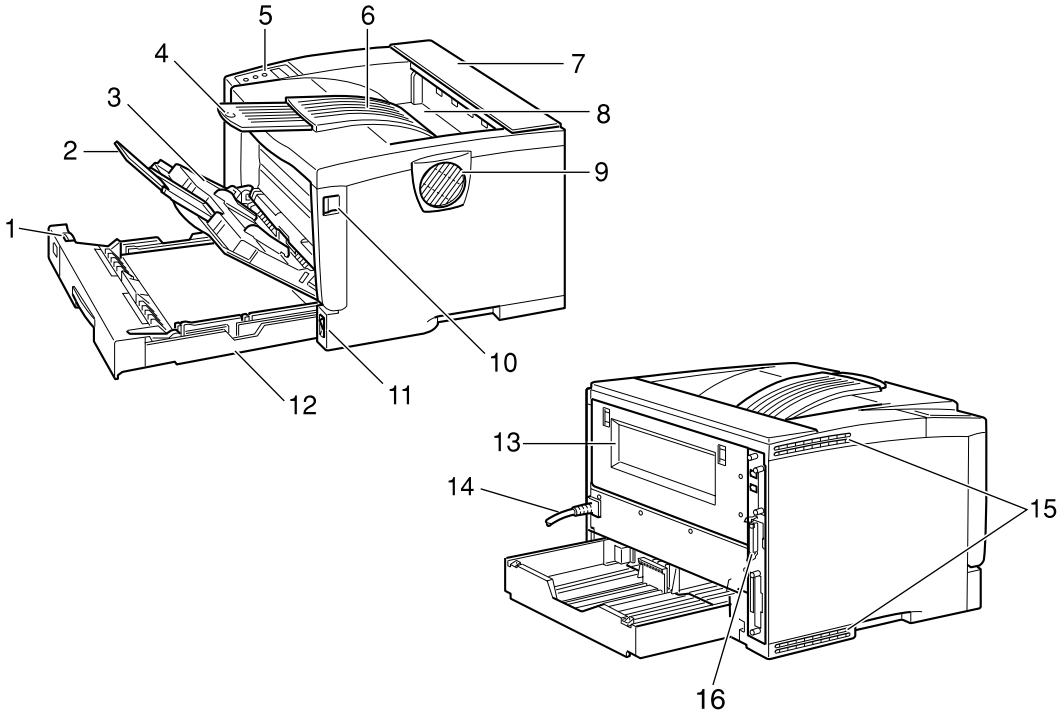

ZGDH141N

1. Paper Size Dial

Adjust this dial to match the size and feed direction of the paper loaded in the paper tray.

2. Bypass Tray Extension

Pull out this extension to load paper into the Bypass Tray when its length is longer than A4 \square or $8\frac{1}{2}'' \times 11'' \square$.

3. Bypass Tray

Use to print onto thick paper, OHP transparencies, adhesive labels, custom size paper, envelopes as well as plain paper. When printing on custom paper size, printer driver settings are required.

Up to 100 sheets of plain paper (80 g/m², 20 lb. bond) can be loaded.

See "Paper and Other Media Supported by this Printer" and "Loading Paper in the Bypass Tray" in the Printer Reference on the CD-ROM labeled "Operating Instructions".

4. Output Tray Extension

Pull out this extension when printing on long paper.

5. Control Panel

Contains keys for the printer operation and a panel display that shows the printer status.

6. Output Tray (Standard Tray)

Printed output is stacked here with the print side facing down.

7. Upper Cover

Remove to install the optional 1-bin Shift Sort Tray or the optional Mailbox.

8. Paper Exit Cover

Open this cover to remove misfed paper.

9. Ventilator

This hole helps to keep components inside the printer from overheating.

Important

- Do not block or obstruct the ventilator. A malfunction may occur due to overheating.

10. Front Cover Release Button

Use this button to open the front cover.

11. Power Switch

Use this switch to turn the printer power on and off.

12. Paper Tray (Tray 1)

Loads up to 250 sheets of plain paper (80 g/m², 20 lb. bond) into this tray for printing.

See *"Paper and Other Media Supported by this Printer"* in the Printer Reference on the CD-ROM labeled "Operating Instructions".

Note

- Paper Tray is displayed "Tray 1" on the panel display.

13. Rear Cover

Remove to install the optional Duplex Unit or to replace the Fusing Unit.

14. Power Cord

Plug this cord into a wall outlet.

15. Ventilators

These holes help to keep components inside the printer from overheating.

Important

- Do not block or obstruct the ventilators. A malfunction may occur due to overheating.

16. Controller Board

Slide it out to install some options. Attach the interface cable, the network interface cable or the 1394 interface cable to the board.

◆ Interior

1

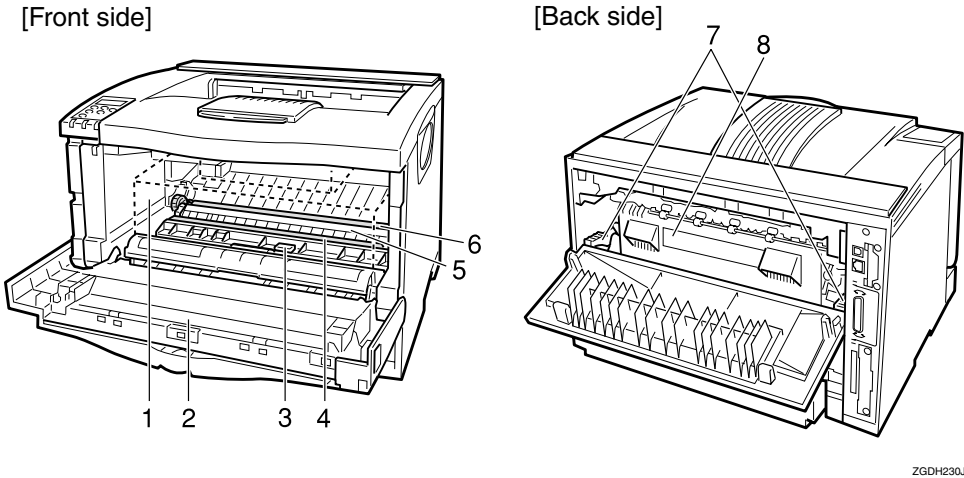

ZGDH230J

1. Toner Cartridge

Includes toner and a photoconductor unit.

When "Replace Toner Cartridge" appears on the panel display, replace this unit.

2. Front Cover

Open this cover when accessing the inside of the printer.

3. Guide Board

Open this board to remove misfed paper.

4. Registration Roller

Feeds the paper. If it becomes dirty, clean it.

See "Cleaning the Registration Roller" in the Printer Reference on the CD-ROM labeled "Operating Instructions".

5. Transfer Roller Cover

Open this cover when replacing a transfer roller.

6. Transfer Roller

When "Replace Maintenance Kit" appears on the panel display, replace this roller.

7. Fusing Unit Lock Levers

Lift these levers when replacing the fusing unit.

8. Fusing Unit

Fuses the image onto paper.

When "Replace Maintenance Kit" appears on the panel display, replace this unit.

Control Panel

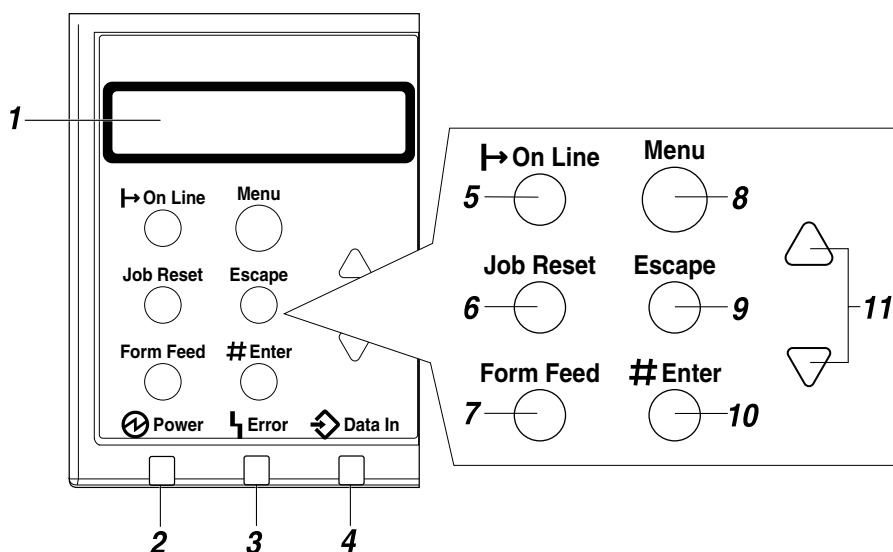

ZDD5100N

1. Panel display

Shows the current status of the printer and error messages.

See "Error & Status Messages on the Control Panel" in the Printer Reference on the CD-ROM labeled "Operating Instructions".

2. Power indicator

Is on while the printer power is on.

Is off when the power is turned off or while the printer is in Energy Saver mode.

3. Error indicator

Blinks or lights up whenever any printer error occurs. A message describing the cause of the error also appears on the panel display.

See "Error & Status Messages on the Control Panel" in the Printer Reference on the CD-ROM labeled "Operating Instructions".

4. Data In indicator

Blinks while the printer is receiving data from a computer.

Is on if there is data to be printed.

5. [On Line] key

Press this key to switch the printer between online and offline.

6. [Job Reset] key

When the printer is online, press this key to cancel any ongoing print job.

See "Canceling a Print job" in the Printer Reference on the CD-ROM labeled "Operating Instructions".

7. [Form Feed] key

If the printer is offline, press this key to print all the data left in the printer's input buffer.

Note

This does not work if the printer is online.

8. [Menu] key

Press this key to make and check the current printer settings.

See "Making Printer Settings with the Control Panel" in the Printer Reference on the CD-ROM labeled "Operating Instructions".

9. [Escape] key

Press this key to return to the previous condition on the panel display.

10. [Enter #] key

Press this key to execute menu items selected on the panel display.

Press this key to clear some errors.

See "*Troubleshooting*" in the Printer Reference on the CD-ROM labeled "Operating Instructions".

11. [▲][▼] keys

Use these keys to increase or decrease values on the panel display when making settings.

2. Installing Options

CAUTION:

- *Be sure to turn off the printer and wait for about an hour before installing options. Not waiting for the printer to cool down can result in a burn.*
- *When lifting the printer, use the inset grips on both sides of the printer, otherwise the printer might fall and cause personal injury.*
- *When you move the printer, unplug the power cord from the wall outlet to avoid a fire or an electric shock.*

Important

- The voltage rating of the connector for options is 24V DC or less.
- Turn the power off before removing the Paper Feed Unit Type 2600, 1-bin Shift Sort Tray Type 2600, or Mailbox CS380. Removing any of these units with the power on may cause the printer to fail.

Option List

Note

- See the inside front cover of this manual to confirm which printer (Basic model or Network standard model) you have.

	Basic model Printer	Network standard model Printer
Paper Feed Unit Type 2600	<input type="radio"/>	<input type="radio"/>
Envelope Feeder Type 2600	<input type="radio"/>	<input type="radio"/>
1-bin Shift Sort Tray Type 2600	<input type="radio"/>	<input type="radio"/>
CS380 (Mailbox)	<input type="radio"/>	<input type="radio"/>
AD410 (Duplex Unit)	<input type="radio"/>	<input type="radio"/>
Memory Unit TypeB 64MB	<input type="radio"/>	<input type="radio"/>
Hard Disk Drive Type 2600	<input type="radio"/>	<input type="radio"/>
Network Interface Board Type 2610 ^{*1}	<input type="radio"/>	
1394 Interface Unit Type 4510 ^{*1 *2}	<input type="radio"/>	<input type="radio"/>
802.11b Interface Unit Type A ^{*1 *2}	<input type="radio"/>	<input type="radio"/>

: Available option

^{*1} With Basic model, these cannot be installed at the same time.

^{*2} With Network standard model, these cannot be attached at the same time.

Note

- Up to two Paper Feed Units can be attached to the printer at the same time.
- The installation of the Paper Feed Unit is necessary to attach the Envelope Feeder Unit.

- Either one of the 1-bin Shift Sort Tray or the Mailbox can be attached to the printer.
- The installation of the Memory Unit is necessary to use the 1394 Interface Unit.

Available Options

2

The following options can be attached to the printer.

◆ Exterior

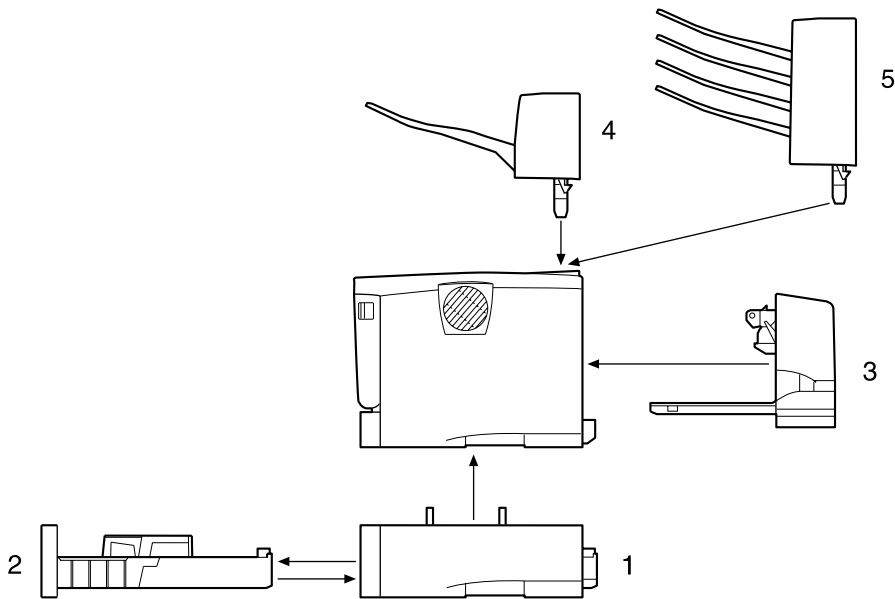

ZCEH150J

1. Paper Feed Unit Type 2600 (Tray 2 or Tray 3)

You can load up to 500 sheets (60-105g/m², 16-28 lb.bond) of plain paper into the tray.

📌 Note

- Do not attach more than two Paper Feed Units to the printer at the same time.
- Top-most optional Paper Feed Unit is displayed "Tray 2" and bottom-most is displayed "Tray 3" on the panel display.

2. Envelope Feeder Type 2600

You can load up to 60 envelopes (72-90g/m², 19-24 lb.bond) into the tray.

📌 Note

- The Envelope Feeder is a tray that slides into the optional Paper Feed Unit. Without the optional Paper Feed Unit, the Envelope Feeder cannot be used.
- The Printer can have two optional Paper Feed Units installed at the same time. However the Envelope Feeder should be used in the top-most optional Paper Feed Unit (Tray 2). It cannot be used in the bottom-most Paper Feed Unit (Tray 3).

3. AD410 (Duplex Unit)

You can print on both sides of paper.

4. 1-bin Shift Sort Tray Type 2600

You can shift and sort the printings.

Note

- The 1-bin Shift Sort Tray and the Mailbox cannot be installed to the printer at the same time.

❖ Basic model Printer : Interior

Note

- See the inside front cover of this manual to confirm which printer (Basic model or Network standard model) you have.

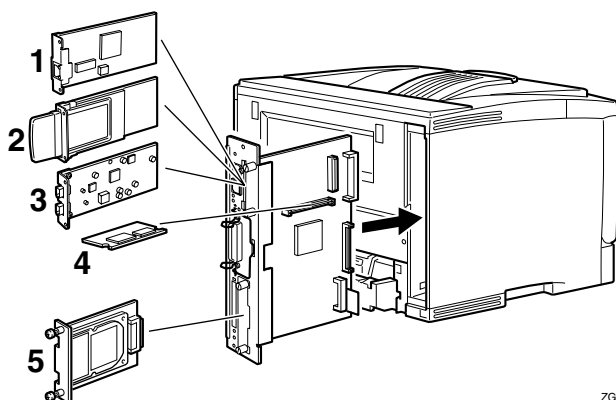

ZGDx120J

1. Network Interface Board Type 2610

You can perform the print job on the network environment.

Note

- The Network Interface Board, the 1394 Interface Unit, and the 802.11b Interface Unit cannot be installed in the printer at the same time.

2. 802.11b Interface Unit Type A

You can perform the print job on the IEEE 802.11b (Wireless LAN) environment.

5. CS380 (Mailbox)

You can sort the printings and also deliver them to each tray separately.

Note

- The 1-bin Shift Sort Tray and the Mailbox cannot be installed to the printer at the same time.

Note

- The Network Interface Board, the 1394 Interface Unit, and the 802.11b Interface Unit cannot be installed in the printer at the same time.

3. 1394 Interface Unit Type 4510

You can perform the print job on the IEEE 1394 environment.

Note

- The Network Interface Board, the 1394 Interface Unit, and the 802.11b Interface Unit cannot be installed in the printer at the same time.

4. Memory Unit TypeB 64MB

You can increase the amount of memory up to 96MB.

5. Hard Disk Drive Type 2600

You can use the “Collate”, the “Sample Print” and the “Locked Print” functions.

❖ Network standard model Printer : Interior

Note

- ❑ See the inside front cover of this manual to confirm which printer (Basic model or Network standard model) you have.

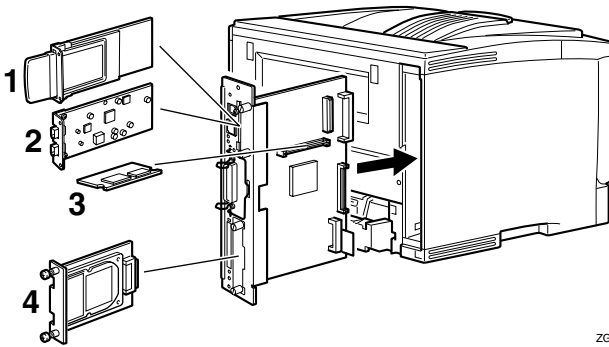

ZGDx121J

1. 802.11b Interface Unit Type A

You can perform the print job on the IEEE 802.11b (Wireless LAN) environment.

3. Memory Unit TypeB 64MB

You can increase the amount of memory up to 96MB.

Note

- ❑ The 1394 Interface Unit and the 802.11b Interface Unit cannot be installed in the printer at the same time.

4. Hard Disk Drive Type 2600

You can use the “Collate”, the “Sample Print” and the “Locked Print” functions.

2. 1394 Interface Unit Type 4510

You can perform the print job on the IEEE 1394 environment.

Note

- ❑ The 1394 Interface Unit and the 802.11b Interface Unit cannot be installed in the printer at the same time.

Paper Feed Unit Type 2600

⚠ Important

- ❑ Do not slide more than one paper tray out at the same time. Having more than one paper tray filled with paper in a fully extended position could cause the machine to fall down.
- ❑ Do not attach more than two Paper Feed Units in your printer at the same time.
- ❑ Check the printer nameplate to confirm the model code.

1 Check the contents of the box for the following items:

- Paper Feed Unit (including a paper tray)
- Installation Guide

2 Confirm that the followings are true:

- The power switch is turned off.
- The power cord is unplugged from the wall outlet.

3 Remove the adhesive tape from the Paper Feed Unit.

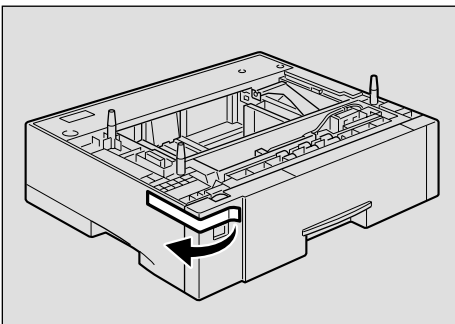

ZCEX390J

📌 Note

- ❑ If you attach two Paper Feed Units at the same time, stack them up in advance.

- ## 4
- There are three pins on the top of the Paper Feed Unit that point straight up. On the bottom of the printer there are three holes. Align the holes over the pins, and then lower the printer gently onto the Paper Feed Unit.

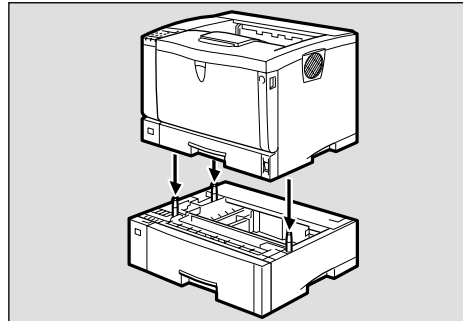

ZGDx400J

⚠ CAUTION:

- When lifting the machine, use the inset grips on both sides. Otherwise the printer could break or cause injury if dropped.

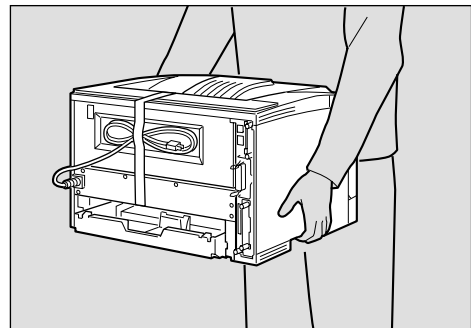

ZGDH052N

- ## 5
- Attach the interface cable to the printer.

- 6** Plug the printer's power cord back into the wall outlet, and then turn on the power switch.

 **Note**

- After installing the last option that you want, print the configuration page to confirm the installation. If the new device is listed in the column of configuration options, then it has been properly installed. For more information about printing the configuration page, see "*Printing the Configuration Page*" in the Printer Reference on the CD-ROM labeled "Operating Instructions".

 **Reference**

For information about loading paper, see "*Loading Paper in the Optional Paper Tray*" in the Printer Reference on the CD-ROM labeled "Operating Instructions".

If the printing position is not correct, adjust the registration of the trays. For more information about adjusting the registration of the trays, see "Adjusting the Registration of the Trays" in the Printer Reference.

Envelope Feeder Type 2600

Note

- This unit is a tray that slides into the optional Paper Feed Unit. Without the optional Paper Feed Unit, this Envelope Feeder cannot be used.
- Your printer can have two optional Paper Feed Units. However, the Envelope Feeder must be used in the top-most optional Paper Feed Unit (Tray 2). It cannot be used in the bottom-most optional Paper Feed Unit (Tray 3).

Important

- Do not slide more than one paper tray out at the same time. Having more than one paper tray filled with paper in a fully extended position could cause the machine to fall down.

1 Check the contents of the box for the following items:

- Envelope Feeder
- Installation Guide

2 Pull out the second paper tray (Tray 2) of the optional Paper Feed Unit until it stops. After that, lift it slightly, and then pull it out.

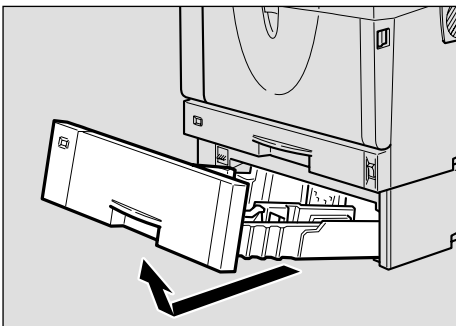

ZDDP330E

Important

- The Envelope Feeder must be used in the top-most optional Paper Feed Unit (Tray 2).
- The tray of the top-most optional Paper Feed Unit is beneath the paper tray.

Note

- Keep the paper tray with paper in a cool dark place.

3 While lifting the front side of the Envelope Feeder, place the feeder into the printer. Then slide it into the printer until it stops.

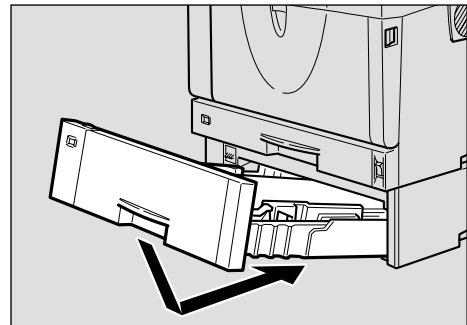

ZDDP340E

Reference

For information about loading paper, see "Loading Envelopes" in the Printer Reference on the CD-ROM labeled "Operating Instructions".

Memory Unit TypeB 64MB

⚠ Important

- ❑ Before touching the Memory Unit, touch something metal to discharge any static electricity. Static electricity can damage the Memory Unit.

1 Check the contents of the box for the following items:

- Memory Unit
- Installation Guide

2 Confirm that the followings are true:

- The power switch is turned off.
- The interface cable is unplugged from the printer.

📝 Note

- ❑ If the Duplex Unit is not attached, go to step **4**.

3 If the Duplex Unit is attached, push down the lever on right side (①) and pull out the Duplex Unit until it stops (②).

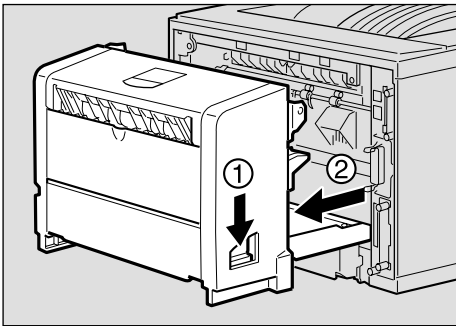

4 Use a coin to remove the two screws.

📝 Note

- ❑ The removed screws are required in step **11**.

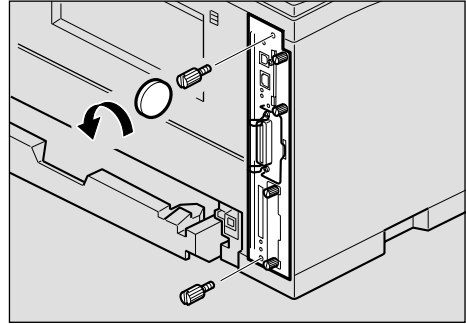

5 Pull out the handle of the controller board.

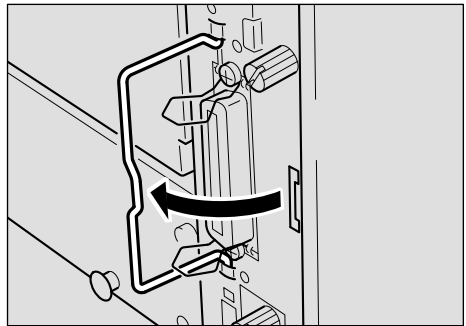

6 Pull the handle and slide the controller board out.

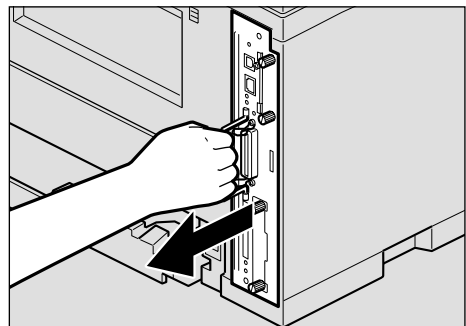

7 Place the controller board on a flat surface.

8 Insert the Memory unit to the slot by placing the notch of the unit to the projection of the slot, and then push it down until it clicks.

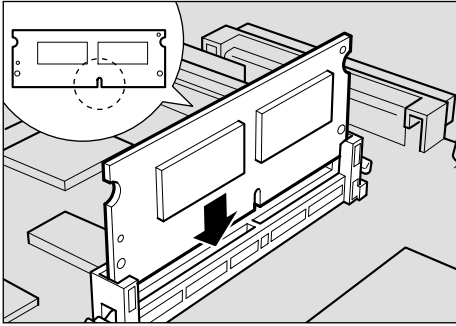

9 Match the controller board to the top and bottom rail using the "▼" mark, and then slide it into the printer slowly until it stops.

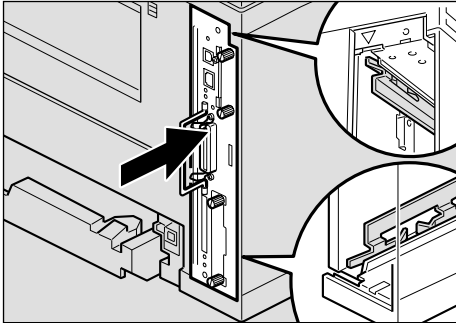

10 Push the handle of the controller board until it clicks.

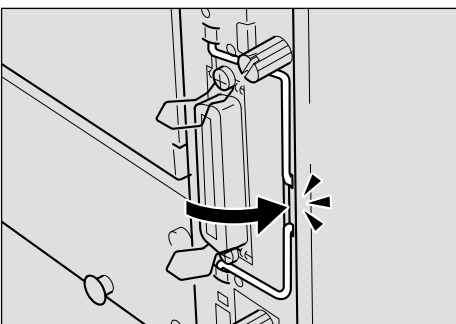

11 Fasten the controller board to the printer with the two screws.

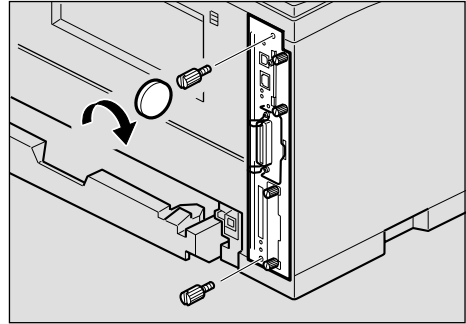

Note

□ If the Duplex Unit is not attached, go to step 14.

12 While aligning the power cord to the left side groove of the Duplex Unit, slide the Duplex Unit in until it is connected to the printer.

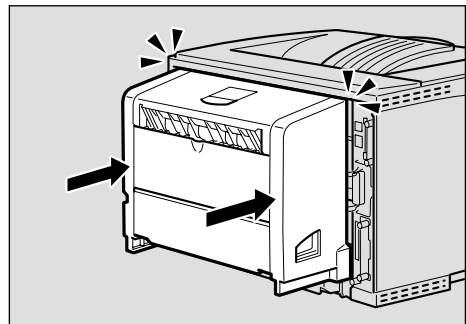

13 Attach the interface cable to the printer.

- 14** Plug the printer's power cord back into the wall outlet, and then turn on the power switch.

 **Important**

- If you use a Windows operating system, you should set up the Memory Unit with the printer driver to make the printer recognize the installation. See the description of Windows 95/98/Me, Windows 2000 and Windows NT 4.0 on p.51 "Installing the Printer Driver and Software".

 **Note**

- After installing the last option that you want, print the configuration page to confirm the installation. If the new device is listed in the column of configuration options, then it has been properly installed. For more information about printing the configuration page, see "*Printing the Configuration Page*" in the Printer Reference on the CD-ROM labeled "Operating Instructions".
- To remove the Memory Unit, press the button on the end of the slot.

Network Interface Board Type 2610

Note

- Depending on the model you use, the Network Interface Board, the 1394 Interface Unit, and the 802.11b Interface Unit cannot be installed to the printer at the same time. For more information, see p.11 “Installing Options”.

Important

- Before touching the Network Interface Board, touch something metal to discharge any static electricity. Static electricity can damage the Network Interface Board.
- Use the shielded twisted-pair (STP) network interface cable.

Installing the Network Interface Board

- 1** Check the contents of the box for the following items:

- Network Interface Board
- Ferrite Core
- Installation Guide

- 2** Confirm that the followings are true:

- The power switch is turned off.
- The interface cable is unplugged from the printer.

Note

- The interface cable is not included in the box. Make sure that the interface cable you use is appropriate for your computer.
- If the Duplex Unit is not attached, go to step **4**.

- 3** If the Duplex Unit is attached, push down the lever on right side (①) and pull out the Duplex Unit until it stops (②).

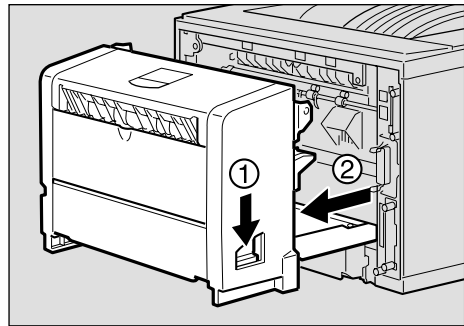

ZGDX320J

- 4** Use a coin to remove the two screws.

Note

- These screws are used again in step **8**.

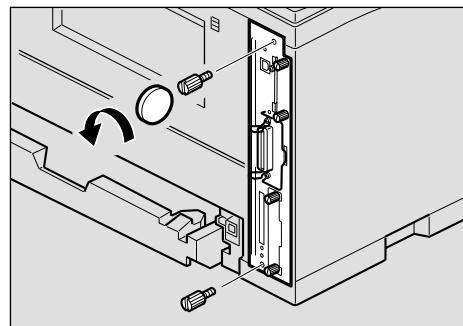

ZGDX281J

- 5** Pull out the handle of the controller board.

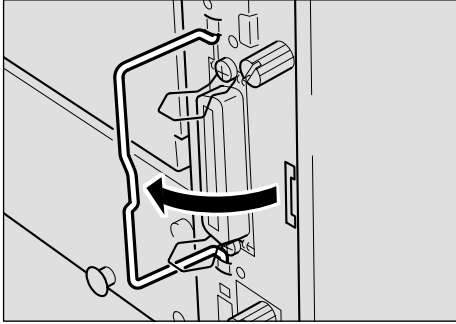

- 6** Pull the handle and slide the controller board out.

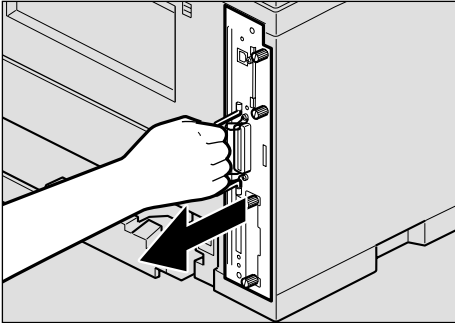

- 7** Place the controller board on a flat surface.

- 8** Use a coin to remove the two screws, and then remove the cover.

Note

- These screws are used again in step 10.
- The removed cover is not used when installing the Network Interface Board.

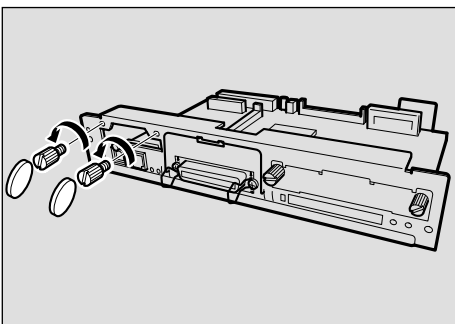

- 9** Insert the end of the Network Interface Board into the opening (1), and then push down until it clicks (2).

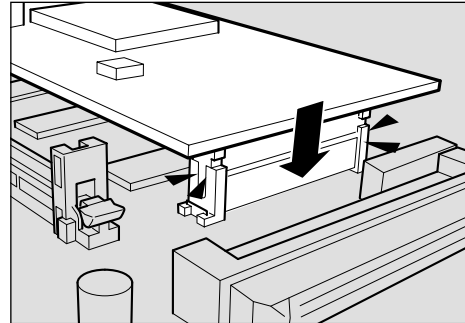
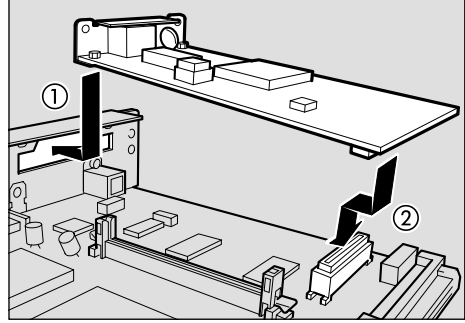

- 10** Fasten the Network Interface Board to the controller board.

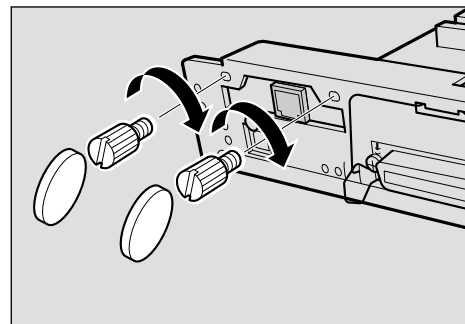

- 11** Match the controller board to the top and bottom rail using the "▼" mark, and then slide it into the printer slowly until it stops.

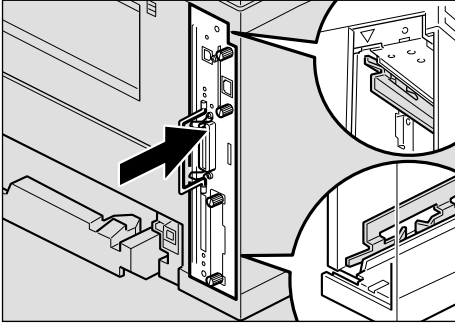

ZGDx253J

- 12** Push back the handle of the controller board until it clicks.

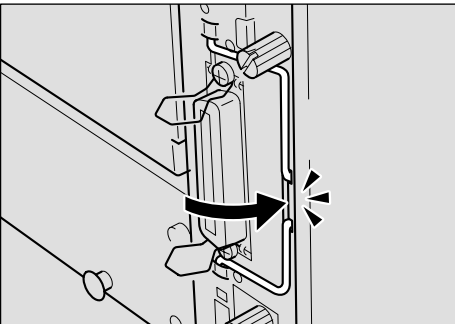

ZGDx380J

- 13** Fasten the controller board to the printer with the two screws.

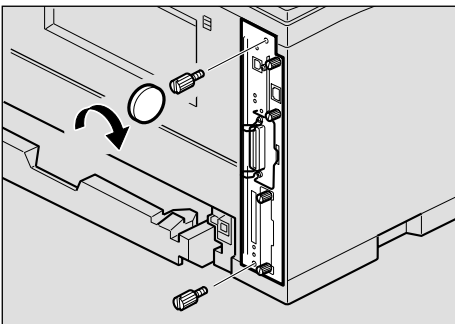

ZGDx271J

- 14** While aligning the power cord to the left side groove of the Duplex Unit, slide the Duplex Unit in until it is connected to the printer.

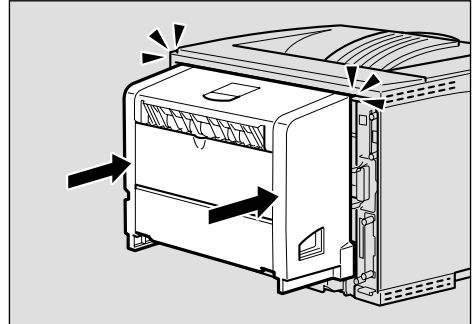

ZGDx241J

- 15** Plug the printer's power cord back into the wall outlet, and then turn on the power switch.

 **Note**

- If the Duplex Unit is not attached, go to step **15**.

Connecting the Network Interface Cable to the Network

- 1 Turn off the power switch.
- 2 Loop the network interface cable and attach the ferrite core.

 **Note**

- The network interface cable loop should be about 15 cm (6") (①) from the end of the cable (on the end closet to the printer). The ferrite core at the end of the cable should be a ring type ferrite core.

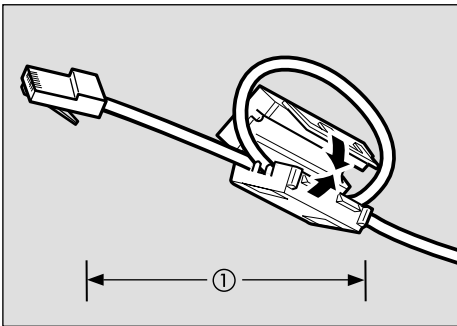

ZDDP320E

- 3 Attach the network interface cable to the jack on the Network Interface Unit.

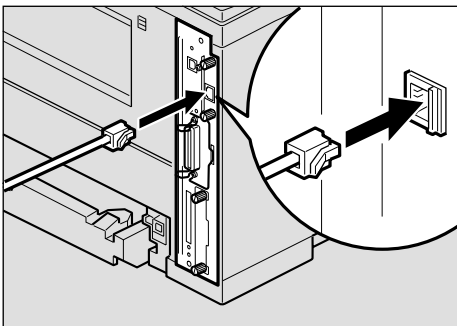

ZGDx291J

- 4 Connect the other end of the network interface cable to the network.

- 5 Turn on the power switch.

 **Note**

- After installing the last option that you want, print the configuration page to confirm the installation. If the information about network settings (e.g. IP address) is listed in the configuration page, then it has been properly installed. For more information about printing the configuration page, see "Printing the Configuration Page" in the Printer Reference on the CD-ROM labeled "Operating Instructions".

1394 Interface Unit Type 4510

Note

- Depending on the model you use, the 1394 Interface Unit, the Network Interface Board, and the 802.11b Interface Unit cannot be installed in the printer at the same time. For more information, see p.11 "Installing Options".

Important

- Printing using "SCSI print "(Windows 2000) device and "IEEE 1394 and SCSI printers" (Windows XP) with the optional 1394 Interface Unit is possible under Windows 2000 and Windows XP. Printing with IP over 1394 is possible under Windows XP.
- With Windows 2000, the 1394 Interface Unit can only be used with Service Pack 1 or later. If the Service Pack is not installed, the connectable SCSI print device in a 1394 bus is only one, and the client cannot install the printer driver without using an account with Administrators permission.
- Before touching the 1394 Interface Unit, touch something metal to discharge any static electricity. Static electricity can damage the 1394 Interface Unit.
- Unplug all the interface cables from the printer before installation. If you take out the controller board with cables plugged in, the 1394 Interface Unit might be damaged.
- Use the 1394 interface cable that comes with this printer.
- Do not plug or unplug the 1394 interface cable while installing the printer driver.

Installing the 1394 Interface Unit

- 1** Check the contents of the box for the following items:

- 1394 Interface Unit
- 1394 Interface Cable (6 pins x 4 pins)
- 1394 Interface Cable (6 pins x 6 pins)
- Installation Guide

- 2** Confirm that the followings are true:

- The power switch is turned off.
- The interface cable is unplugged from the printer.

Note

- If the Duplex Unit is not attached, go to step **4**.

- 3** If the Duplex Unit is attached, push down the lever on right side (①) and pull out the Duplex Unit until it stops (②).

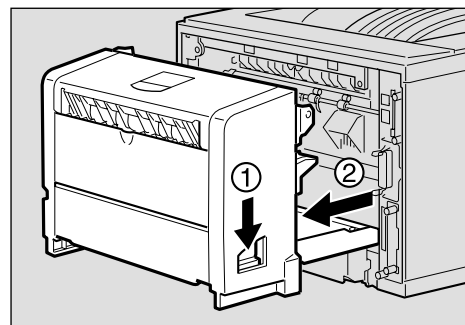

ZGDX320J

4 Use a coin to remove the two screws.

Note

☐ These screws are used again in step 10.

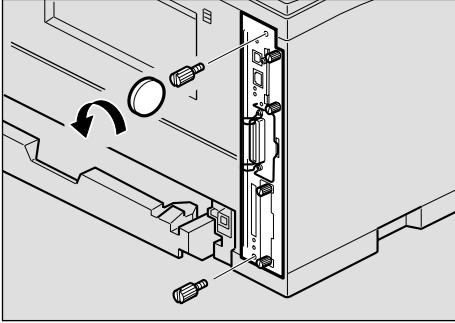

ZGDx280J

5 Pull out the handle of the controller board.

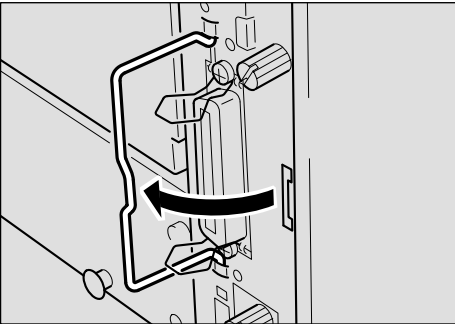

ZGDx370J

6 Pull the handle and slide the controller board out.

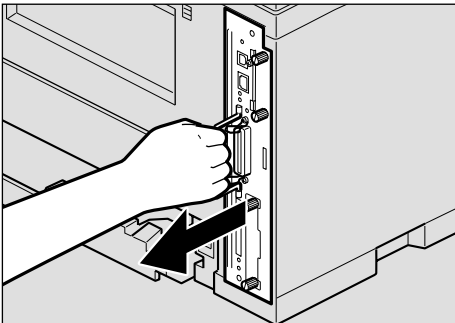

ZGDx260J

7 Place the controller board on a flat surface.

8 Use a coin to remove the two screws, and then remove the cover.

Note

☐ These screws are used again in step 10.

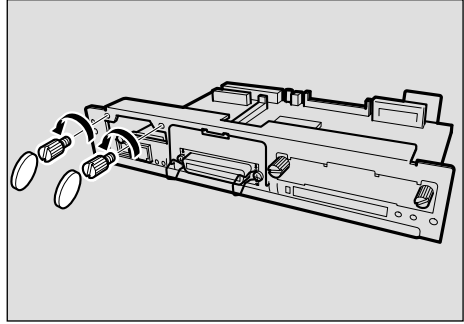

ZGDx410J

9 Attach the 1394 Interface Unit to the controller board.

Insert the end of the 1394 Interface Unit into the opening (1), and then push down until it clicks (2).

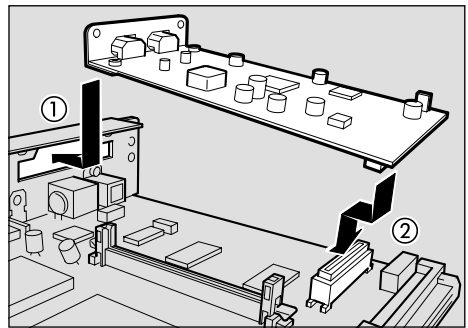

ZGDx421J

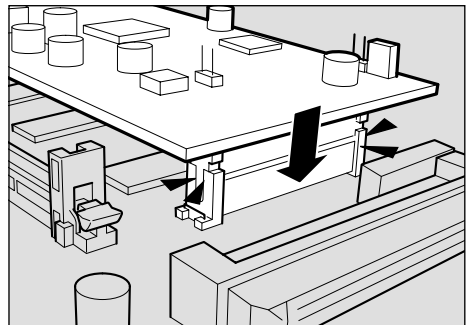

ZGDx430J

- 10** Fasten the 1394 Interface Unit to the controller board.

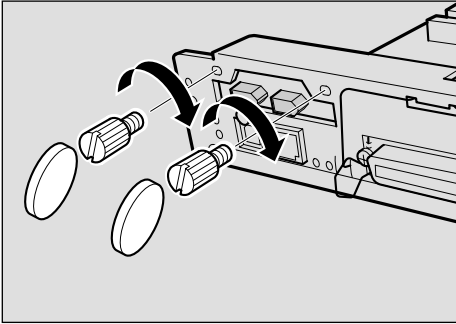

ZGDx443J

- 13** Fasten the controller board to the printer with the two screws.

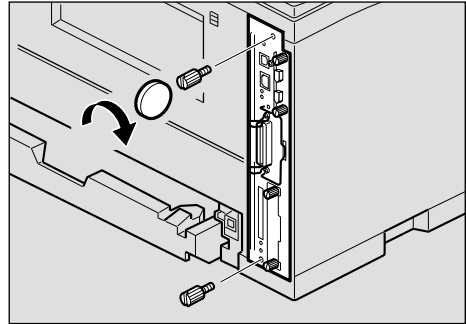

ZGDx272J

- 11** Match the controller board to the top and bottom rail using the "▼" mark, and then slide it into the printer slowly until it stops.

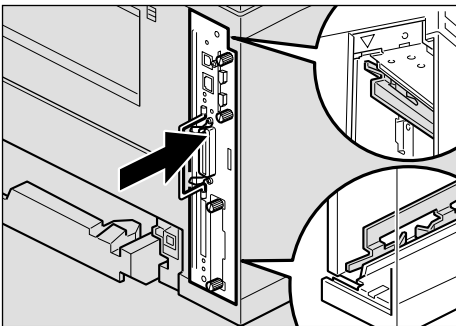

ZGDx252J

- 12** Push back the handle of the controller board until it clicks.

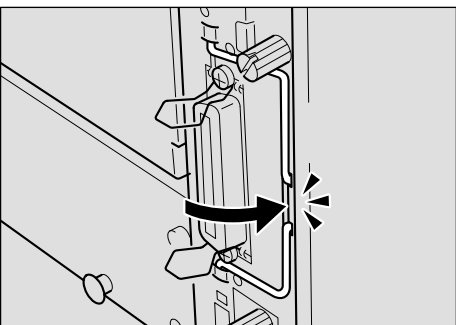

ZGDx380J

Note

- If the Duplex Unit is not attached, go to step 15.

- 14** While aligning the power cord to the left side groove of the Duplex Unit, slide the Duplex Unit in until it is connected to the printer.

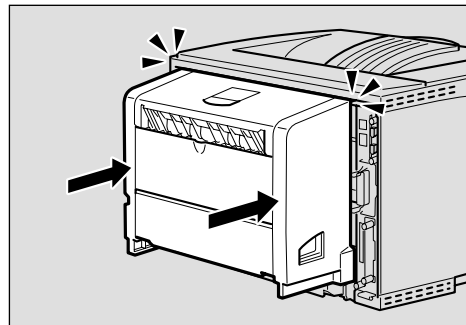

ZGDx242J

- 15** Plug the printer's power cord back into the wall outlet, and then turn on the power switch.

You need to make settings with the control panel before using the 1394 Interface Unit.

Connecting the 1394 Interface Cable to the Printer

- 1 Attach the 1394 interface cable to the jack on the 1394 Interface Unit.

Both types of jack are available.

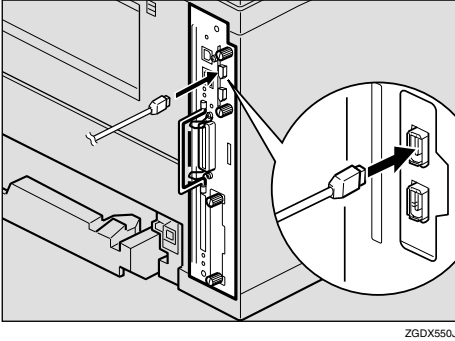

- 2 Connect the other end of the 1394 interface cable to the computer or the other IEEE 1394 node.

Note

- ❑ After installing the last option that you want, print the configuration page to confirm the installation. If the new device is listed in the column of configuration options, then it has been properly installed. For more information about printing the configuration page, see "Printing the Configuration Page" in the Printer Reference on the CD-ROM labeled "Operating Instructions".

1394 Interface Unit specifications

- ❖ **Interface Connector:**
IEEE 1394 (6 pins × 2)
- ❖ **Required cable:**
1394 interface cable (6 pins × 4 pins, 6 pins × 6 pins)
- ❖ **Important**
 - ❑ You cannot plug devices together to create loops.
 - ❑ Do not use a cable more than 4.5 meters (14.8 feet) long.
- ❖ **Connectable number of devices in a bus:**
Maximum 63
- ❖ **Allowed cable hops in a bus:**
Maximum 16
- ❖ **Power supply:**
Nonpower supply
Cable Power repeated (IEEE 1394a-2000 compliant)

802.11b Interface Unit Type A

Note

- Depending on the model you use, the 802.11b Interface Unit, the 1394 Interface Unit, and the Network Interface Board cannot be installed to the printer at the same time. For more information, see p.11 “Installing Options”.

Important

- Before touching the 802.11b Interface Unit, touch something metal to discharge any static electricity. Static electricity can damage the 802.11b Interface Unit.

1 Check the contents of the box for the following items:

- 802.11b Interface Unit
- Installation Guide

2 Confirm that the followings are true:

- The power switch is turned off.
- The interface cable is unplugged from the printer.

Note

- If the Duplex Unit is not attached, go to step 4.

3 If the Duplex Unit is attached, push down the lever on right side (①) and pull out the Duplex Unit until it stops (②).

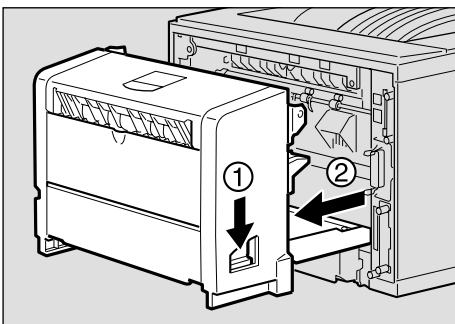

4 Use a coin to remove the two screws.

Note

- These screws are used again in step 4.

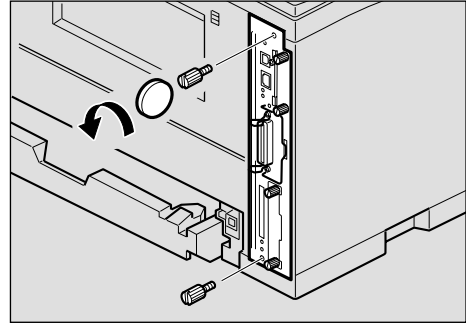

5 Pull out the handle of the controller board.

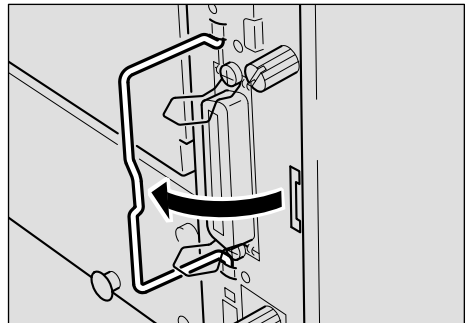

6 Pull the handle and slide the controller board out.

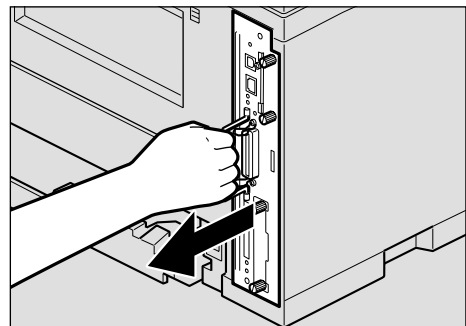

7 Place the controller board on a flat surface.

8 Use a coin to remove the two screws, and then remove the cover.

Note

☐ These screws are used again in step 10.

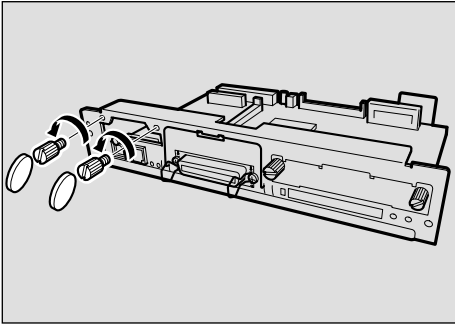

ZGDx410J

9 Attach the 802.11b Interface Unit.

Insert the end of the 802.11b Interface Unit into the opening (1), and then push down until it clicks (2).

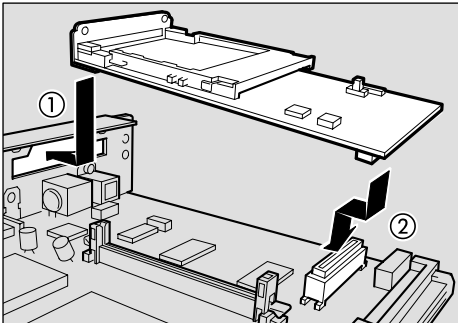

ZGDx420J

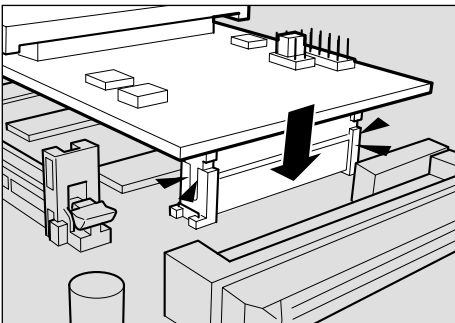

ZGDx431J

10 Fasten the 802.11b Interface Unit to the controller board with the two screws.

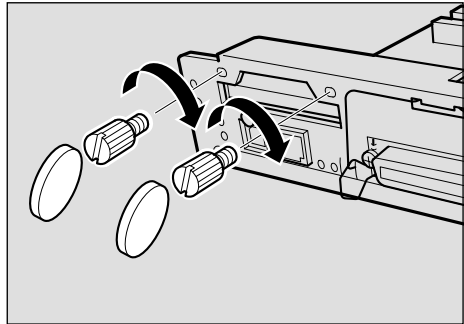

ZGDx442J

11 Insert the card slowly into the 802.11b board with the label facing down and the uneven black antenna surface facing up until it stops.

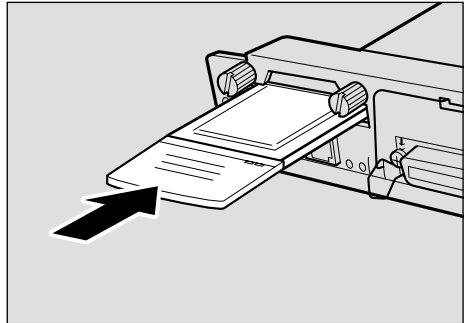

ZGDx500J

12 Match the controller board to the top and bottom rail using the "▼" mark, and then slide it into the printer slowly until it stops.

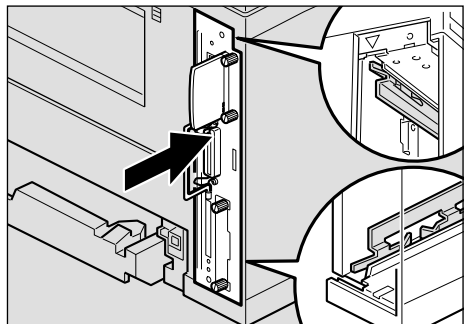

ZGDx251J

- 13** Push back the handle of the controller board until it clicks.

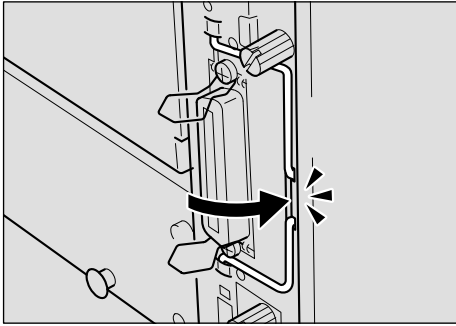

ZGDX380J

- 14** Fasten the controller board to the printer with the two screws.

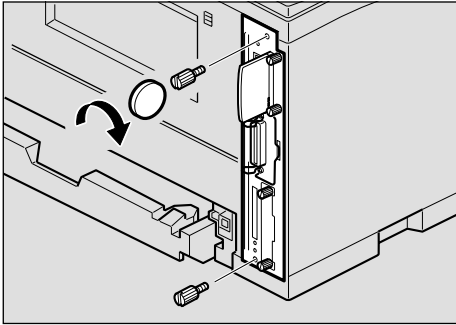

ZGDX273J

Note

- If the Duplex Unit is not attached, go to step 16.

- 15** While aligning the power cord to the left side groove of the Duplex Unit, slide the Duplex Unit in until it is connected to the printer.

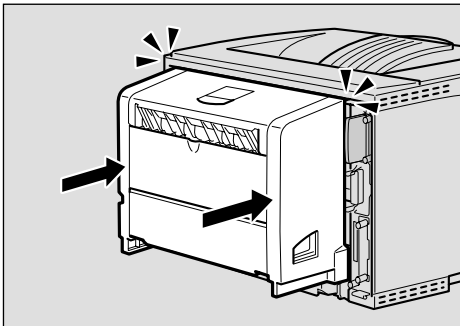

ZGDX243J

- 16** Plug the printer's power cord back into the wall outlet, and then turn on the power switch.

You need to make settings with the control panel before using the 802.11b Interface Unit.

Note

- After installing the last option that you want, print the configuration page to confirm the installation. If the new device is listed in the column of configuration options, then it has been properly installed. For more information about printing the configuration page, see "Printing the Configuration Page" in the Printer Reference on the CD-ROM labeled "Operating Instructions".

Hard Disk Drive Type 2600

⚠ Important

- ❑ Before touching the Hard Disk Drive, touch something metal to discharge any static electricity. Static electricity can damage the Hard Disk Drive.

1 Check the contents of the box for the following items:

- Hard Disk Drive
- Installation Guide

2 Confirm that the followings are true:

- The power switch is turned off.
- The interface cable is unplugged from the printer.

3 Use a coin to remove the two screws, and then remove the cover.

🔧 Note

- ❑ The screws and cover are not used when installing the Hard Disk Drive.

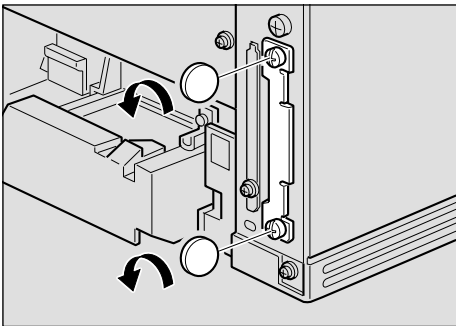

4 Slowly insert the Hard Disk Drive while aligning it with the top and bottom rails in the printer until it stops.

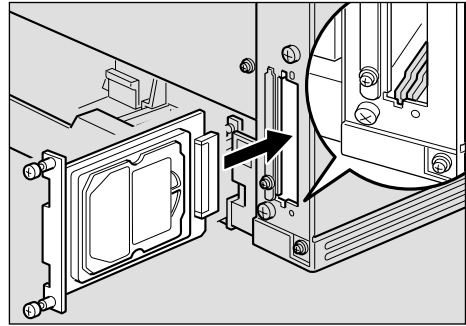

5 Fasten the Hard Disk Drive.

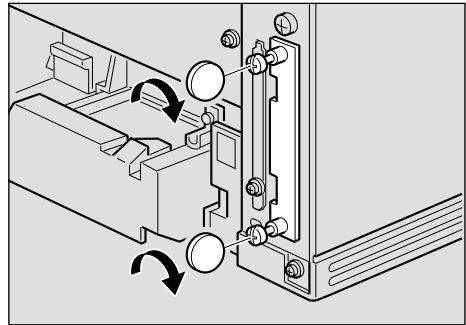

6 Attach the interface cable to the printer.

7 Plug the printer's power cord back into the wall outlet, and then turn on the power switch.

The following message appears on the panel display.

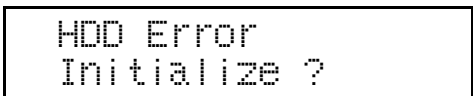

- 8** Press **[Enter #]** to format the Hard Disk Drive.

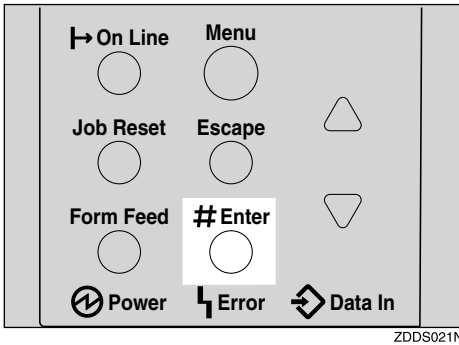

Important

- Do not turn off the printer while formatting the Hard Disk Drive. Turning off the printer while formatting the Hard Disk Drive can damage the Hard Disk Drive.

If you successfully format the Hard Disk Drive, the following message appears on the panel display.

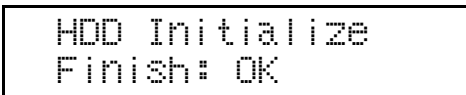

- 9** Press **[On Line]**.

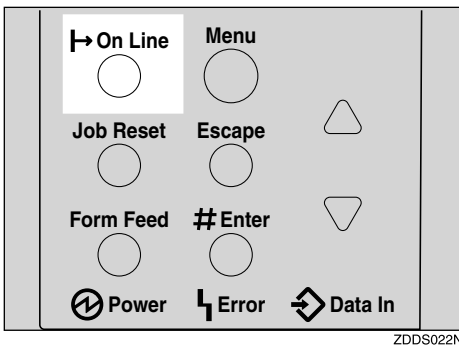

"Ready" appears on the panel display.



Important

- If you use a Windows operating system, you should set up the Hard Disk Drive with the printer driver to make the printer recognize the installation. See a description of Windows 95/98/Me, Windows 2000 and Windows NT 4.0 on p.51 "Installing the Printer Driver and Software".

Note

- After installing the last option that you want, print the configuration page to confirm the installation. If the new device is listed in the column of configuration options, then it has been properly installed. For more information about printing the configuration page, see "Printing the Configuration Page" in the Printer Reference on the CD-ROM labeled "Operating Instructions".

AD410 (Duplex Unit)

Important

- ❑ If you attach the Duplex Unit and the Paper Feed Unit, the Paper Feed Unit must be attached prior to attaching the Duplex Unit.
- ❑ Check the printer nameplate to confirm the model code.

1 Check the contents of the box for the following items:

- Duplex Unit
- Installation Guide

2 Confirm that the followings are true:

- The power switch is turned off.

3 Remove the adhesive tapes.

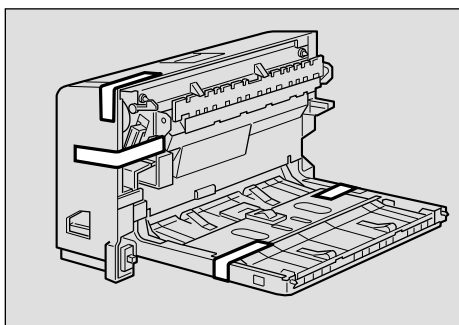

ZCEX310J

4 Open the rear cover by pushing the two knobs as shown in the illustration.

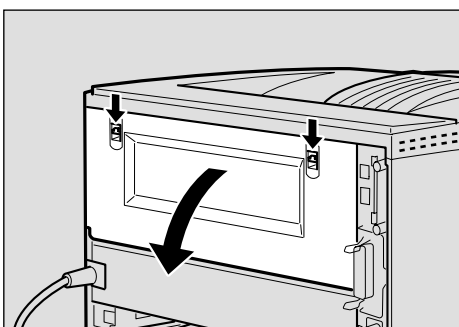

ZGDX210J

5 Remove the rear cover in the horizontal direction.

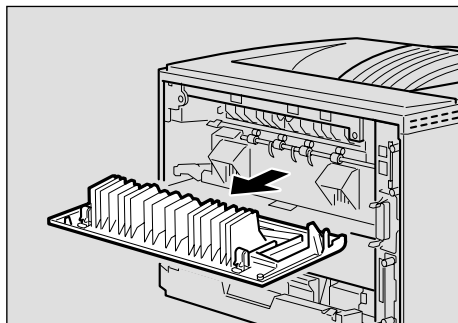

ZGDX220J

Note

- ❑ The rear cover of the printer is not used when attaching the Duplex Unit.

6 While aligning the power cord to the left side groove of the Duplex Unit, slide the Duplex Unit in until it is connected to the printer.

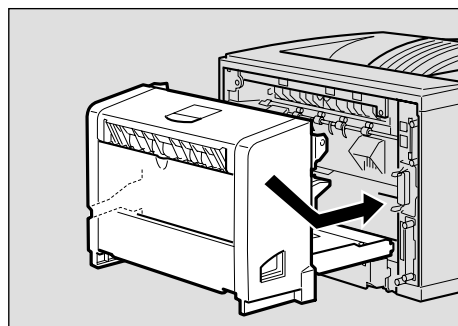

ZGDX231E

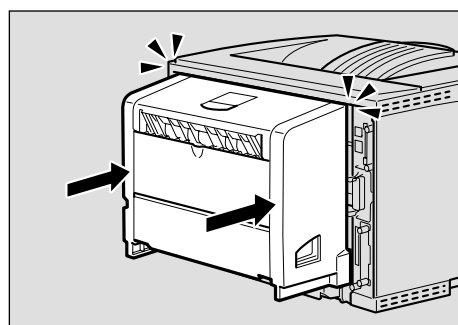

ZGDX240J

7 Attach the interface cable to the printer.

8 Plug the printer's power cord back into the wall outlet, and then turn on the power switch.

 **Note**

- After installing the last option that you want, print the configuration page to confirm the installation. If the new device is listed in the column of configuration options, then it has been properly installed. For more information about printing the configuration page, see "*Printing the Configuration Page*" in the Printer Reference on the CD-ROM labeled "Operating Instructions".
- If the printing position is not correct, adjust the registration of the trays. For more information about adjusting the registration of the trays, see "Adjusting the Registration of the Trays" in the Printer Reference.

1-bin Shift Sort Tray Type 2600

Important

- ❑ If you attach the 1-bin Shift Sort Tray and the Paper Feed Unit, the Paper Feed Unit must be attached prior to attaching the 1-bin Shift Sort Tray.
- ❑ The 1-bin Shift Sort Tray and the Mailbox cannot be attached to the printer at the same time.
- ❑ Check the printer nameplate to confirm the model code.

1 Check the contents of the box for the following items:

- 1-bin Shift Sort Tray
- Upper Tray
- Installation Guide

2 Confirm that the followings are true:

- The power switch is turned off.
- The interface cable is unplugged from the printer.

3 Remove the adhesive tapes and the packing material.

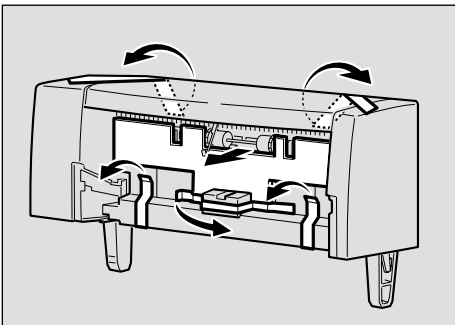

ZOEX300J

4 Remove the upper cover of the printer.

Note

- ❑ The upper cover that is removed, is not used when installing the 1-bin Shift Sort Tray.

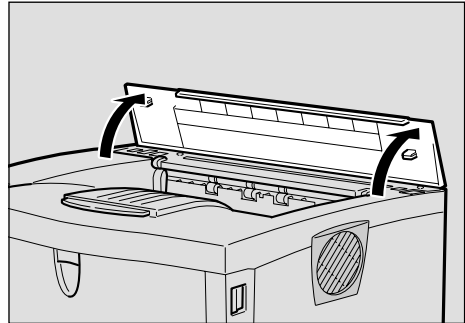

ZGDH170J

5 Holding the 1-bin Shift Sort Tray on both sides, align the catches with the holes on the printer and insert.

CAUTION:

- When lifting the 1-bin Shift Sort Tray, hold it on both sides. Holding underneath the 1-bin Shift Sort Tray may cause injury to the hands if caught between the 1-bin Shift Sort Tray and the printer.

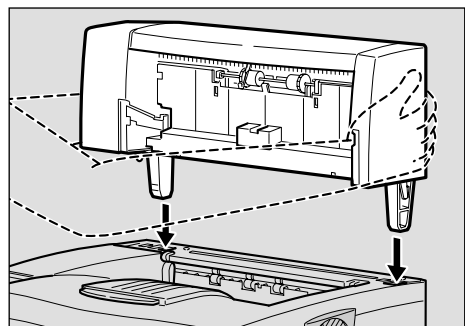

ZGDH170J

- Slide the upper tray into the 1-bin Shift Sort Tray.

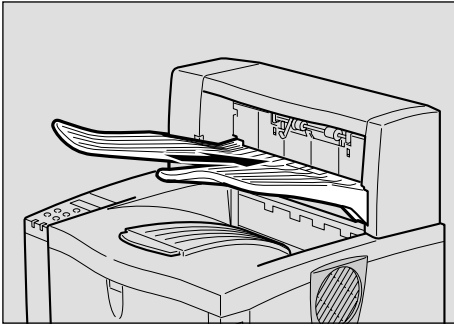

- Attach the interface cable to the printer.
- Plug the printer's power cord back into the wall outlet, and then turn on the power switch.

 **Note**

- After installing the last option that you want, print the configuration page to confirm the installation. If the new device is listed in the column of configuration options, then it has been properly installed. For more information about printing the configuration page, see "Printing the Configuration Page" in the Printer Reference on the CD-ROM labeled "Operating Instructions".

CS380 (Mailbox)

Important

- ❑ If you attach the Mailbox and the Paper Feed Unit, the Paper Feed Unit must be attached prior to attaching the Mailbox.
- ❑ The Mailbox and the 1-bin Shift Sort Tray cannot be attached to the printer at the same time.
- ❑ Check the printer nameplate to confirm the model code.

1 Check the contents of the box for the following items:

- Mailbox
- Output Trays (4pcs)
- Output Tray Number Seal
- Installation Guide

2 Confirm that the followings are true:

- The power switch is turned off.

3 Remove the adhesive tapes and the packing materials.

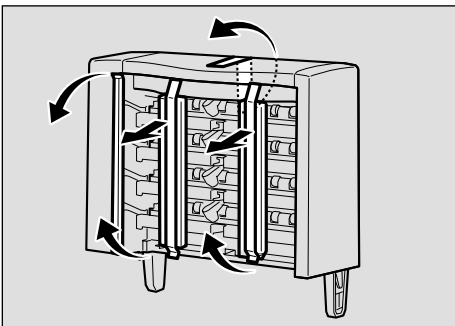

ZCEX451J

4 Remove the upper cover of the printer.

Note

- ❑ The upper cover that is removed, is not used when attaching the Mailbox.

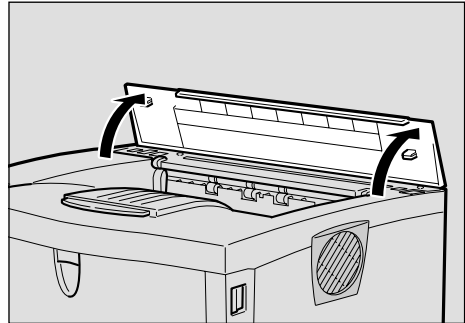

ZGDH170J

5 Holding the Mailbox on both sides, align the catches with the holes on the printer and insert.

CAUTION:

- When lifting Mailbox, hold it on both sides. Holding underneath the Mailbox may cause injury to the hands if the Mailbox and the printer.

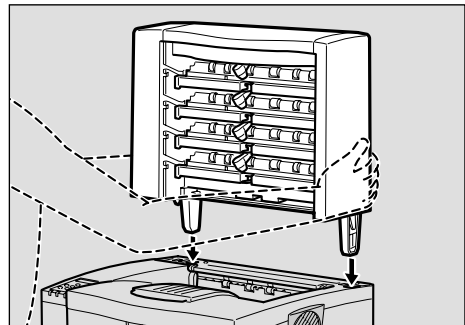

ZGDX190J

- 6 Slide the output tray into the lower side of the Mailbox first.

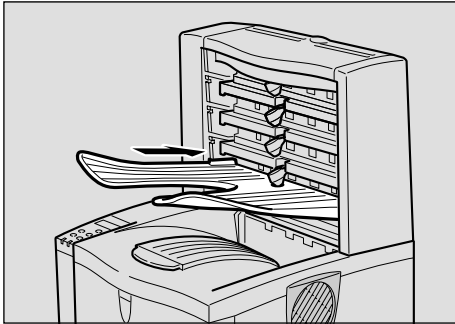

- 7 Slide the other output trays into the Mailbox from the bottom.
- 8 Attach the interface cable to the printer.
- 9 Plug the printer's power cord back into the wall outlet, and then turn on the power switch.

 **Note**

- After installing the last option that you want, print the configuration page to confirm the installation. If the new device is listed in the column of configuration options, then it has been properly installed. For more information about printing the configuration page, see "Printing the Configuration Page" in the Printer Reference on the CD-ROM labeled "Operating Instructions".

3. Configuring the Printer for the Network

Make the network settings below depending on the network interface you use.

- Parallel/USB: Making network settings is not necessary. Go to p.51 “Installing the Printer Driver and Software”.
- Ethernet: Make the settings in p.41 “Ethernet Configuration”, and then see p.51 “Installing the Printer Driver and Software”.
- IEEE 1394: Make the settings in p.45 “IEEE 1394 Configuration”, and then see p.51 “Installing the Printer Driver and Software”.
- Wireless LAN: Make the settings in p.48 “IEEE 802.11b (Wireless LAN) Configuration”, and then see p.51 “Installing the Printer Driver and Software”.

Note

- The optional Network Interface Board is necessary to use Ethernet with Basic model printer.
- The optional 1394 Interface Unit is necessary to use IEEE 1394.
- The optional 802.11b Interface Unit is necessary to use the wireless LAN.

Ethernet Configuration

Configure the printer for the network using the printer's control panel.

The following table shows the control panel settings and their default values. These items are included in the “Host Interface” menu.

Reference

For information about configuring the computer for the network, see the Network Printing Guide on the CD-ROM labeled “Operating Instructions”.

For information about “Host Interface” menu, see “Host Interface Menu” in the Printer Reference on the CD-ROM labeled “Operating Instructions”.

Setting Name	Value	
IP Address	011.022.033.044	
Subnet Mask	000.000.000.000	
Gateway Address	000.000.000.000	
Network Boot	None	
Frame Type (NW) (Frame type NetWare)	Auto	
Active Protocol	TCP/IP	<input type="radio"/> *1
	NetWare	<input type="radio"/> *1
	NetBEUI	<input type="radio"/> *1
	AppleTalk	<input type="radio"/> *1
Ethernet *2	Auto	
LAN Type *3	Ethernet	

*1 means that this protocol is active.

*2 Make this setting only when it is necessary.

*3 Appears only when both the Network Interface Board and the 802.11b Interface Unit are installed.

1 Press **[Menu]**.

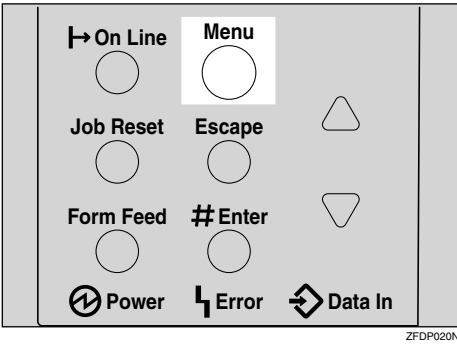

"Menu" appears on the panel display.

2 Press **[▲]** or **[▼]** to display "Host Interface" menu.



3 Press **[Enter #]**.

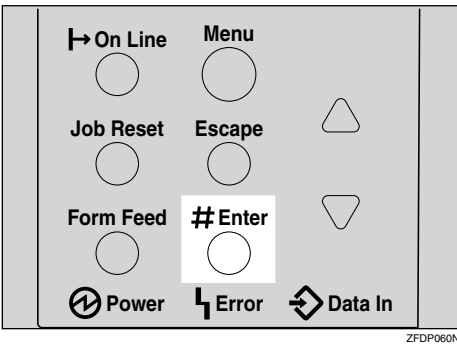

The following message appears on the panel display.

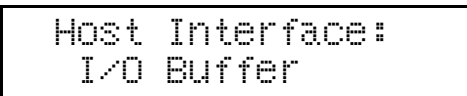

4 Press **[▲]** or **[▼]** to display "Network Setup".

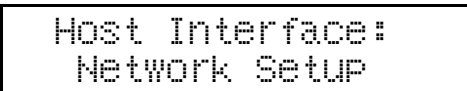

5 Press **[Enter #]**.

The following message appears on the panel display.



6 Select the protocol you want to use.

Note

Do not select protocols that are not used on your network.

1 Press **[▲]** or **[▼]** to display "Active Protocol".

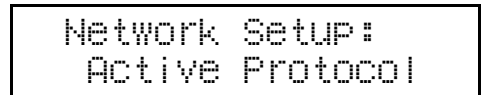

2 Press **[Enter #]**.

The current setting appears on the panel display.



3 Press **[Enter #]**.

4 Press **[▲]** or **[▼]** to select "Active" or "Not Active", and then press **[Enter #]**.

5 Set other protocols you need to set in the same way.

Note

Leave unused protocols "Not Active".

- 7** If you use TCP/IP, assign the IP address to the printer.

 **Note**

- To get the IP address for the printer, contact your network administrator.

- 1** Press **[▲]** or **[▼]** until the following message appears.

```
Network Setup:
IP Address
```

- 2** Press **[Enter #]**.

The current IP address appears on the panel display.

```
IP Address:
011.022.033.044
```

- 3** Press **[▲]** or **[▼]** to enter the left most entry field of the IP address.

```
IP Address:
192.022.033.044
```

- 4** Press **[Enter #]**.

The pointer (█) moves to the next entry field automatically.

```
IP Address:
192.02█.033.044
```

 **Note**

- The value moves by 10 if **[▲]** or **[▼]** is kept pressed.
- You can return the pointer (█) to the previous (left) entry field by pressing **[Escape]**.
- If you press **[Escape]** when the pointer (█) is on the left-most position, the selected IP address is reset.

- 5** Repeat steps **3** and **4** to enter the IP address.

```
IP Address:
192.168.000.011
```

Check if the pointer (█) is at the rightmost position, and press **[Enter #]** to register the IP address you selected.

```
Network Setup:
IP Address
```

- 8** If you use TCP/IP, assign "Subnet Mask" and "Gateway Address" following the same procedure for entering the IP address.

- 9** If you use TCP/IP, you can make settings for "Network Boot".

You can select how to assign the printer's address using the computer. Select one of the items below if necessary.

- None (Default)
- DHCP

- 1** Press **[▲]** or **[▼]** to display "Network Boot".

```
Network Setup:
Network Boot
```

- 2** Press **[Enter #]**.

The current setting appears on the panel display.

```
Network Boot:
*None
```

- 3** Press **[▲]** or **[▼]** to display the method you want to use.

- 4** Press **[Enter #]**.

10 If you use NetWare, select the frame type for NetWare.

Select one of the items below if necessary.

- Auto (Default)
- Ethernet 802.3
- Ethernet 802.2
- Ethernet II
- Ethernet SNAP

Note

Usually, use the default setting (“Auto”). When you first select “Auto”, the frame type detected by the printer is adopted. If your network can use more than two frame types, the printer may fail to select the correct frame type if “Auto” is selected. In this case, select the appropriate frame type.

1 Press **[▲]** or **[▼]** to display “Frame Type (NW)”.

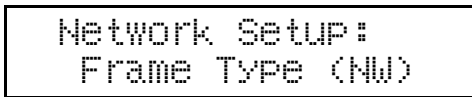

2 Press **[Enter #]**.
The current setting appears on the panel display.



3 Press **[▲]** or **[▼]** to display the frame type you want to use.

4 Press **[Enter #]**.

11 Select the interface.

Ethernet and IEEE 802.11b appear only when both the Network Interface Board and the 802.11b Interface Unit are installed.

Select one of the items below.

- Ethernet
- IEEE 802.11b

1 Press **[▲]** or **[▼]** to display “LAN Type”.



2 Press **[Enter #]**.
The current setting appears on the panel display.

3 Press **[▲]** or **[▼]** to display “Ethernet”.



4 Press **[Enter #]**.

12 Press **[On Line]**.

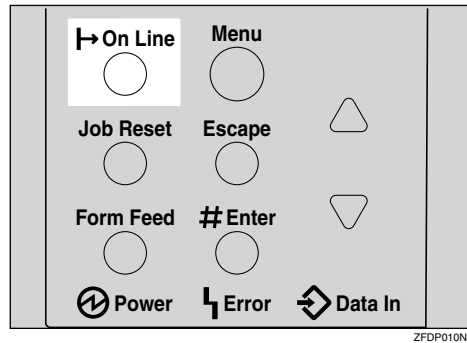

“Ready” appears on the panel display.



13 Print a configuration page to confirm the settings made. See “Printing a Configuration Page” in the Printer Reference.

The settings are now complete. Go to p.51 “Installing the Printer Driver and Software”.

IEEE 1394 Configuration

Use this procedure to configure the printer for use in the IEEE 1394 environment. The following table shows the control panel settings and their default values. These items are included in the "Host Interface" menu.

Setting Name	Value
IP Address1394	000.000.000.000
Subnet Mask1394	000.000.000.000
IP over 1394	Active
SCSI print	Active
Bidi-SCSI print	Active

Depending on the protocol you use, procedures vary. See the following table.

IP over 1394	Steps 1-3 and then go to steps 6 to 7
SCSI print	Steps 1-3 and then go to steps 9 to 10

1 Press [Menu].

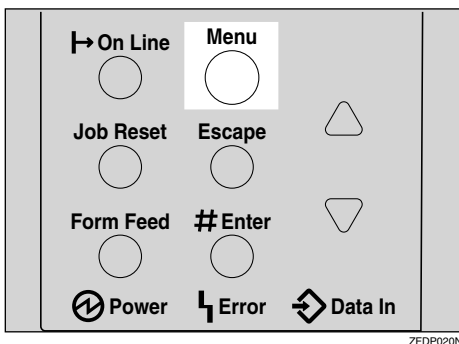

"Menu" appears on the panel display.

2 Press [▲] or [▼] to display "Host Interface" menu.

```
Menu:
Host Interface
```

3 Press [Enter #].

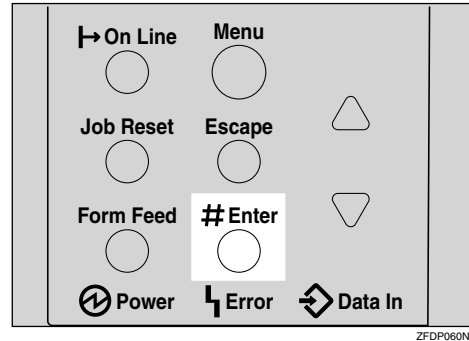

The following message appears on the panel display.

```
Host Interface:
I/O Buffer
```

4 Press [▲] or [▼] to display "IEEE 1394 Setup".

```
Host Interface:
IEEE 1394 Setup
```

5 Press [Enter #].

The following message appears on the panel display.

```
IEEE 1394 Setup:
IP Address1394
```

6 Press [▲] or [▼] to display "IP over 1394".

```
IEEE 1394 Setup:
IP over 1394
```

1 Press [Enter #].

2 Press [▲] or [▼] to select either "Active" or "Not Active".

3 Press [Enter #].

The display returns to the previous menu in a few seconds.

7 Assign the IP address to the printer.

Do not overlap the IP address in the same subnet or the same IP address in the network setting.

 **Note**

- To get the IP address for the printer, contact your network administrator.

1 Press **[▲]** or **[▼]** until the following message appears.

```
IEEE 1394 Setup:
IP Address1394
```

2 Press **[Enter #]**.

The current IP address appears on the panel display.

```
IP Address1394:
000.000.000.000
```

3 Press **[▲]** or **[▼]** to enter the leftmost entry field of the IP address.

```
IP Address1394:
192.022.033.044
```

4 Press **[Enter #]**.

The pointer (█) moves to the next entry field automatically.

```
IP Address1394:
192.02█.033.044
```

 **Note**

- The value moves by 10 if **[▲]** or **[▼]** is kept pressed.
- You can return the pointer (█) to the previous (left) entry field by pressing **[Escape]**.
- If you press **[Escape]** when the pointer (█) is on the leftmost position, the selected IP address is reset.

5 Repeat steps **3** and **4** to enter the IP address.

```
IP Address1394:
192.168.000.011
```

Check if the pointer (█) is at the rightmost position, and press **[Enter #]** to register the IP address you selected.

```
IEEE 1394 Setup:
IP Address1394
```

8 Set "Subnet Mask1394" in the same way.

9 Set "SCSI print" and "Bidi-SCSI print" if necessary.

 **Note**

- The default setting is "Active".

10 Press **[▲]** or **[▼]** to display "SCSI print".

```
IEEE 1394 Setup:
SCSI Print
```

11 Press **[Enter #]**.

The following message appears on the panel display.

```
SCSI Print:
*Active
```

12 Press **[▲]** or **[▼]** to select either "Active" or "Not Active", and then press **[Enter #]**.

Set " Bidi-SCSI print " in the same way.

13 Press **[On Line]**.

“Ready” appears on the panel display.

**14** Print a configuration page to confirm the settings made. See "Printing a Configuration Page" in the Printer Reference.

The settings are now complete. Go to p.51 "Installing the Printer Driver and Software".

IEEE 802.11b (Wireless LAN) Configuration

Configure the printer for using the wireless LAN. The following table shows the control panel settings and their default values. These items are included in the "Host Interface" menu.

Setting Name	Value
Comm. Mode	Ad hoc
Channel	• Inch version (1-11) 11
	• Metric version (1-13) 11
Trans. Speed	Auto
WEP Settings	Not Active

In order to use the wireless LAN, select "IEEE 802.11b" for "LAN Type" in "Network Setup" of the Host Interface menu, and then set "IP Address", "Subnet Mask", "Gateway Address", "Network Boot", "Frame Type (NW)" and "Active Protocol" in the "Network Setup". For more information about setting the items in the "Network Setup", see p.41 "Ethernet Configuration".

1 Press **[Menu]**.

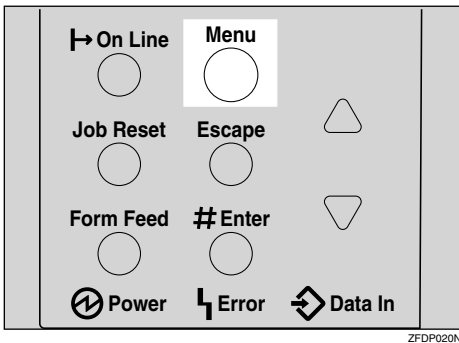

"Menu" appears on the panel display.

2 Press **[▲]** or **[▼]** to display "Host Interface" menu.



3 Press **[Enter #]**.

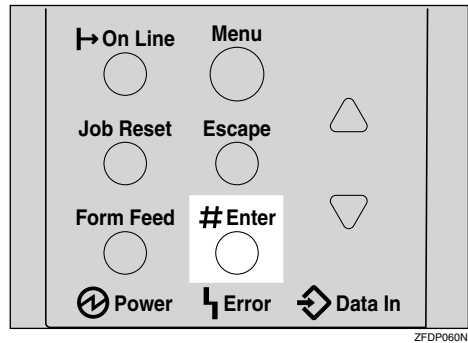

The following message appears on the panel display.

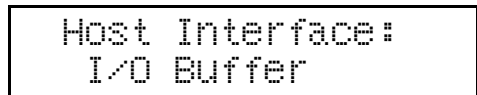

4 Press **[▲]** or **[▼]** to display "IEEE 802.11b".

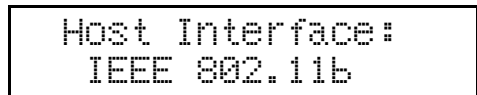

5 Press **[Enter #]**.

Be sure that "Comm. Mode" appears on the panel display.

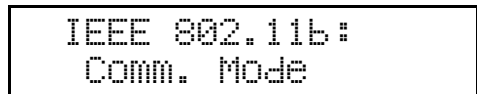

6 Press **[Enter #]**.

The following message appears on the panel display.

```
Comm. Mode :
*Ad hoc
```

7 Press **[▲]** or **[▼]** to select the transmission mode.**8** Press **[Enter #]**.

The display returns to the previous menu in a few seconds.

9 Set "Trans. Speed" and "WEP Settings" in the same way.

For more information about WEP Settings, see "Using the IEEE 802.11b (Wireless LAN)" in the Network Printing Guide.

10 If "Ad hoc" is selected for "Comm. Mode", set the channel to use for transmission. **Note**

- Confirm the network administrator for the channel to use.

1 Press **[▲]** or **[▼]** to display "Channel".

```
IEEE 802.11b :
Channel
```

2 Press **[Enter #]**.

The channel currently used appears on the panel display.

```
Channel :
(1-11)   11
```

3 Press **[▲]** or **[▼]** to enter the channel.**4** Press **[Enter #]**.**11** Press **[On Line]**.

"Ready" appears on the panel display.

```
Ready
```

12 Print a configuration page to confirm the settings made. See "Printing a Configuration Page" in the Printer Reference.

The settings are now complete. Go to p.51 "Installing the Printer Driver and Software".

 **Address**❖ **Subnet Mask**

A number used to mathematically "mask" or hide an IP address on the network by eliminating those parts of the address that are alike for all the machines on the network.

❖ **Gateway Address**

A gateway is a connection or interchange point that connects two networks. A gateway address is for the router or host computer used as a gateway.

 **Note**

- To get the addresses, contact your network administrator.

3

4. Installing the Printer Driver and Software

This manual assumes that you are familiar with general Windows procedures and practices. If you are not, see the documentation that comes with Windows for details.

Installation Method

The following table shows how to install the printer drivers and software.

	Auto Run ^{*1}		
	Quick Install		Custom installation ^{*2}
	Network connection with TCP/IP	Parallel connection	
PCL 6 printer driver	○	○	○
PCL 5e printer driver			○
RPCS printer driver	○	○	○
PostScript printer driver			○
Agfa Monotype Font Manager 2000			○
SmartNetMonitor for Admin			○
SmartNetMonitor for Client	○		○

^{*1} Available operating systems are as follows: Windows 95/98/Me, Windows 2000, Windows XP, Windows NT 4.0

^{*2} Using custom installation, you can install various software separately.

Reference

When the printer is connected to the computer using USB, see p.66 "Installing the Printer Driver Using USB".

When the printer is connected to the computer using IEEE 1394, see p.68 "Installing the Printer Driver Using IEEE 1394".

Important

- Before starting this installation, close all documents and applications. In a network environment, confirm that users who are logged on are disconnected. Be sure to do this when it will create the least interference with other users.
- After installing a printer driver, you must restart the computer.

Note

- If the "plug and play" function starts, click **[Cancel]** in the **[New Hardware Found]**, **[Device Driver Wizard]** or **[Found New Hardware Wizard]** dialog box, and then insert the CD-ROM. The **[New Hardware Found]**, **[Device Driver Wizard]** or **[Found New Hardware Wizard]** dialog box appears depending on the system version of Windows 95/98/Me, or Windows 2000/Windows XP.

Quick Install

Auto Run will start the installer automatically when you load the CD-ROM in the CD-ROM drive. By selecting Quick Install, you can install the necessary software easily.

TCP/IP requires the following:

- This machine must be connected to the network through the network interface cable.
- This machine must be turned on.
- The TCP/IP protocol must be configured.
- An IP address must be allocated to this machine and to the computer.

4

Limitation

- If your system is Windows 2000/Windows XP or Windows NT 4.0, installing a printer driver by Auto Run requires Administrators permission. When you install a printer driver by Auto Run, log on using an account that has Administrators permission.
- When the printer is connected to the computer using USB or IEEE 1394, Quick Install cannot be used. See p.66 "Installing the Printer Driver Using USB" or p.68 "Installing the Printer Driver Using IEEE 1394".

Note

- Auto Run might not automatically work with certain OS settings. In this case, launch "Setup.exe" located on the CD-ROM root directory.

If you want to cancel Auto Run, hold down the **[SHIFT]** key (when your system is Windows 2000/Windows XP, hold down the left **[SHIFT]** key) while inserting the CD-ROM. Keep the **[SHIFT]** key held down until the computer has finished accessing the CD-ROM.

1 Close all applications that are running.

2 Insert the CD-ROM into the CD-ROM drive.

Auto Run will start the installer.

3 Select a language to change the interface language, and then click **[OK]**.

The following languages are available: Cestina (Czech), Dansk (Danish), Deutsch (German), English (English), Espanol (Spanish), Francais (French), Italiano (Italian), Magyar (Hungarian), Nederlands (Dutch), Norsk (Norwegian), Polski (Polish), Portugues (Portuguese), Suomi (Finnish), Svenska (Swedish)

Default interface language is English.

4 Select **[Quick Install]**.

- 5** The software license agreement appears in the **[License Agreement]** dialog box.

After reading through all of the contents, click **[I accept the agreement]** to agree with the license agreement, and then click **[Next]**.

- 6** Click to select a model name you want to use when the "Select Printer" dialog box appears.

 **Note**

- For a network connection with TCP/IP, select the printer whose IP address is displayed in **[Connect To]**.
- For parallel connection, select the printer whose printer port is displayed in **[Connect To]**.

- 7** Click **[Install]**.

- 8** Follow the instructions on the screen.

 **Note**

- During installation in Windows 2000, the **[Digital Signature Not Found]** dialog box may appear. In this case, click **[Yes]** to continue the installation.
- During installation in Windows XP, the **[Hardware Installation]** dialog box may appear. In this case, click **[Continue Anyway]** to continue the installation.

A message prompting you to restart your computer may appear. To complete the installation, restart your computer.

Installing the PCL 6/5e Printer Driver

Installing the PCL 6/5e Printer Driver

Two kinds of PCL printer drivers, PCL 6 and PCL 5e, are provided with this printer. We recommend PCL 6 as your first choice.

Limitation

- If your system is Windows 2000/Windows XP or Windows NT 4.0, installing a printer driver by Auto Run requires Administrators permission. When you install a printer driver by Auto Run, log on using an account that has Administrators permission.

Important

- When updating the printer driver by installing the latest version, you should uninstall that of former version if any. See *“Uninstalling the Printer Driver and Software”* in the Printer Reference.

1 Close all applications that are running.

2 Insert the CD-ROM into the CD-ROM drive.

Auto Run will start the installer.

3 Select a language to change the interface language, and then click [OK].

The following languages are available: Cestina (Czech), Dansk (Danish), Deutsch (German), English (English), Espanol (Spanish), Francais (French), Italiano (Italian), Magyar (Hungarian), Nederlands (Dutch), Norsk (Norwegian), Polski (Polish), Portugues (Portuguese), Suomi (Finnish), Svenska (Swedish)

Default interface language is English.

4 Select [PCL/RPCS Printer Drivers].

5 The software license agreement appears in the [License Agreement] dialog box.

After reading through all of the contents, click [I accept the agreement] to agree with the license agreement, and then click [Next].

6 Select the printer driver you want to install when the "Select Program" dialog box appears.

7 Follow the instructions on the screen.

Note

- During installation in Windows 2000, the [Digital Signature Not Found] dialog box may appear. In this case, click [Yes] to continue the installation.
- During installation in Windows XP, the [Hardware Installation] dialog box may appear. In this case, click [Continue Anyway] to continue the installation.

Setting Up Options

Important

- If the printer is equipped with certain options, you should set up the options with the printer driver.

Limitation

- In Windows 2000/Windows XP, changing the printer settings requires Manage Printers permission. Members of the Administrators and Power Users groups have Manage Printers permission by default. When you set up options, log on using an account that has Manage Printers permission.
- In Windows NT 4.0, changing the setting of the printer requires Full Control permission. Members of the Administrators, Server Operators, Print Operators, and Power Users groups have Full Control permission by default. When you set up options, log on using an account that has Full Control permission.

Note

- When setting up options, you should access the Printer Properties dialog box from Windows. You cannot set up options by accessing the Printer Properties dialog box from an application.

1 Click **[Start]** on the taskbar, point to **[Settings]**, and then click **[Printers]**.

The **[Printers]** window appears.

Note

- With Windows XP, access the **[Printers and Faxes]** window from **[Start]** on the taskbar.

2 Click to select the icon of the printer you want to use.

3 On the **[File]** menu, click **[Properties]**.

The Printer Properties appear.

4 Click the **[Accessories]** tab.

5 Select options you have installed from the **[Options]** group.

6 Click **[OK]**.

Installing the RPCS Printer Driver

Installing the RPCS Printer Driver

Limitation

- If your system is Windows 2000/Windows XP or Windows NT 4.0, installing a printer driver by Auto Run requires Administrators permission. When you install a printer driver by Auto Run, log on using an account that has Administrators permission.

Important

- When updating the printer driver by installing the latest version, you should uninstall that of former version if any. See *"Uninstalling the Printer Driver and Software"* in the Printer Reference.

1 Close all applications that are running.

2 Insert the CD-ROM into the CD-ROM drive.

Auto Run will start the installer.

3 Select a language to change the interface language, and then click **[OK]**.

The following languages are available: Cestina (Czech), Dansk (Danish), Deutsch (German), English (English), Espanol (Spanish), Francais (French), Italiano (Italian), Magyar (Hungarian), Nederlands (Dutch), Norsk (Norwegian), Polski (Polish), Portugues (Portuguese), Suomi (Finnish), Svenska (Swedish)

Default interface language is English.

4 Select **[PCL/RPCS Printer Drivers]**.

5 The software license agreement appears in the **[License Agreement]** dialog box.

After reading through all of the contents, click **[I accept the agreement]** to agree with the license agreement, and then click **[Next]**.

6 Select the RPCS printer driver when the "Select Program" dialog box appears.

7 Follow the instructions on the screen.

Note

- During installation in Windows 2000, the **[Digital Signature Not Found]** dialog box may appear. In this case, click **[Yes]** to continue the installation.
- During installation in Windows XP, the **[Hardware Installation]** dialog box may appear. In this case, click **[Continue Anyway]** to continue the installation.

Setting Up Options

Important

- If the printer is equipped with certain options, you should set up the options with the printer driver.

Limitation

- In Windows 2000/Windows XP, changing the printer settings requires Manage Printers permission. Members of the Administrators and Power Users groups have Manage Printers permission by default. When you set up options, log on using an account that has Manage Printers permission.
- In Windows NT 4.0, changing the setting of the printer requires Full Control permission. Members of the Administrators, Server Operators, Print Operators, and Power Users groups have Full Control permission by default. When you set up options, log on using an account that has Full Control permission.

Note

- When setting up options, you should access the Printer Properties dialog box from Windows. You cannot set up options by accessing the Printer Properties dialog box from an application.

1 Click **[Start]** on the taskbar, point to **[Settings]**, and then click **[Printers]**.

The **[Printers]** window appears.

Note

- With Windows XP, access the **[Printers and Faxes]** window from **[Start]** on the taskbar.

2 Click to select the icon of the printer you want to use.

3 On the **[File]** menu, click **[Properties]**.

The Printer Properties appear.

4 Click the **[Accessories]** tab.

5 Select options you have installed from the **[Options]** group.

6 Click **[OK]**.

Installing the PostScript Printer Driver

This section describes basic instructions for installing the PostScript printer driver. The actual procedure may differ depending on the operating system. Follow the appropriate procedures below.

Important

- When updating the printer driver by installing the latest version, you should uninstall that of former version if any. See “*Uninstalling the Printer Driver and Software*” in the Printer Reference.

Windows 95/98/Me - Installing the PostScript Printer Driver

4

Installing the printer driver

1 Close all applications that are running.

2 Insert the CD-ROM into the CD-ROM drive.

Auto Run will start the installer.

3 Select a language to change the interface language, and then click [OK].

The following languages are available: Cestina (Czech), Dansk (Danish), Deutsch (German), English (English), Espanol (Spanish), Francais (French), Italiano (Italian), Magyar (Hungarian), Nederlands (Dutch), Norsk (Norwegian), Polski (Polish), Portugues (Portuguese), Suomi (Finnish), Svenska (Swedish)

Default interface language is English.

Note

- The printer driver with the selected language will be installed.
- The printer driver will be installed in English if you select the following languages: Cestina, Magyar, Polski, Portugues and Suomi.

4 Select [PostScript 3 Printer Driver].

[Add Printer Wizard] starts.

5 Click [Next].

6 Check [Local Printer] and then click [Next].

A dialog box for selecting the printer appears.

7 Select the printer you want to use, and then click [Next].

8 Follow the instructions on the screen.

Setting up options

Important

- If the printer is equipped with certain options, you should set up the options with the printer driver.

1 Click **[Start]** on the taskbar, point to **[Settings]**, and then click **[Printers]**.

The **[Printers]** window appears.

2 Click to select the icon of the printer you want to use.

3 On the **[File]** menu, click **[Properties]**.

The Printer Properties appear.

4 Click the **[Accessories]** tab.

5 Select options you have installed from the **[Options]** group.

6 Click **[OK]**.

4

Windows 2000/Windows XP - Installing the PostScript Printer Driver

Installing the printer driver

Limitation

- Installing a printer driver requires Administrators permission. When you install a printer driver, log on using an account that has Administrators permission.

1 Close all applications that are running.

2 Insert the CD-ROM into the CD-ROM drive.

Auto Run will start the installer.

3 Select a language to change the interface language, and then click **[OK]**.

The following languages are available: Cestina (Czech), Dansk (Danish), Deutsch (German), English (English), Espanol (Spanish), Francais (French), Italiano (Italian), Magyar (Hungarian), Nederlands (Dutch), Norsk (Norwegian), Polski (Polish), Portugues (Portuguese), Suomi (Finnish), Svenska (Swedish)

Default interface language is English.

Note

- The printer driver with the selected language will be installed.
- The printer driver will be installed in English if you select the following languages: Cestina, Magyar, Polski, Portugues and Suomi.

4 Select **[PostScript 3 Printer Driver]**.

[Add Printer Wizard] starts.

5 Click **[Next]**.

6 Check **[Local Printer]** and then click **[Next]**.

A dialog box for selecting the printer port appears.

7 Select the check box of the port you want to use, and then click **[Next]**.

A dialog box for selecting the printer appears.

8 Select the printer you want to use, and then click **[Next]**.

9 Follow the instructions on the screen.

 **Note**

During installation, the **[Digital Signature Not Found]** dialog box may appear. In this case, click **[Yes]** to continue the installation.

During installation in Windows XP, the **[Hardware Installation]** dialog box may appear. In this case, click **[Continue Anyway]** to continue the installation.

Setting up options

 **Important**

If the printer is equipped with certain options, you should set up the options with the printer driver.

 **Limitation**

Changing the printer settings requires Manage Printers permission. Members of the Administrators and Power Users groups have Manage Printers permission by default. When you set up options, log on using an account that has Manage Printers permission.

1 Click **[Start]** on the taskbar, point to **[Settings]**, and then click **[Printers]**.

The **[Printers]** window appears.

 **Note**

With Windows XP, access the **[Printers and Faxes]** window from **[Start]** on the taskbar.

2 Click to select the icon of the printer you want to use.

3 On the **[File]** menu, click **[Properties]**.

The Printer Properties appear.

4 Click the **[Device Settings]** tab.

5 Select options you have installed from the **[Installable Options]**.

6 Click **[OK]**.

Windows NT 4.0 - Installing the PostScript Printer Driver

Installing the printer driver

Limitation

- Installing a printer driver requires Administrators permission. When you install a printer driver, log on using an account that has Administrators permission.

Important

- The CD-ROM containing the Windows NT Server operating system version 4.0, or the Windows NT Workstation operating system is required for installing the printer driver.
- We recommend that you upgrade the Windows NT 4.0 operating system to Service Pack 4 or later before installing the printer driver. Contact your Windows retailer for more information about the latest version available.

1 Close all applications that are running.

2 Insert the CD-ROM into the CD-ROM drive.

Auto Run will start the installer.

3 Select a language to change the interface language, and then click [OK].

The following languages are available: Cestina (Czech), Dansk (Danish), Deutsch (German), English (English), Espanol (Spanish), Francais (French), Italiano (Italian), Magyar (Hungarian), Nederlands (Dutch), Norsk (Norwegian), Polski (Polish), Portugues (Portuguese), Suomi (Finnish), Svenska (Swedish)

Default interface language is English.

Note

- The printer driver with the selected language will be installed.
- The printer driver will be installed in English if you select the following languages: Cestina, Magyar, Polski, Portugues and Suomi.

4 Select [PostScript 3 Printer Driver].

[Add Printer Wizard] starts.

5 Click [Next].

6 After confirming that the [My Computer] option is selected, click [Next].

A dialog box for selecting the printer port appears.

7 Select the check box of the port you want to use, and then click [Next].

A dialog box for selecting the printer appears.

8 Select the printer you want to use, and then click [Next].

9 Follow the instructions on the screen.

Setting up options

Limitation

- Changing the printer settings requires Manage Printers permission. Members of the Administrators and Power Users groups have Manage Printers permission by default. When you set up options, log on using an account that has Manage Printers permission.

Important

- If the printer is equipped with certain options, you should set up the options with the printer driver.

1 Click **[Start]** on the taskbar, point to **[Settings]**, and then click **[Printers]**.

The **[Printers]** window appears.

2 Click to select the icon of the printer you want to use.

3 On the **[File]** menu, click **[Properties]**.

The Printer Properties appear.

4 Click the **[Device Settings]** tab.

5 Select options you have installed from the **[Installable Options]** group.

6 Click **[OK]**.



Bidirectional transmission

When bidirectional transmission is enabled, information about the paper size and feed direction settings is automatically sent to the machine by a computer. You can also check the machine's status from your computer.

- Bidirectional transmissions are supported by Windows 95/98/Me, Windows 2000/Windows XP and Windows NT 4.0.
- When bidirectional transmission is running, the machine status and information are obtained by opening the printer driver screen.

To support bidirectional transmission, the following conditions are required:

◆ When connecting with a parallel cable

- The computer must support bidirectional transmission.
- The printer must be set to bidirectional transmission.
- The Interface cable must support bidirectional transmission.
- The machine must be connected to the computer using the standard parallel cable and parallel connector.
- Under Windows 95/98/Me, **[Enable bidirectional support for this printer]** must be selected in **[Spool Settings...]** on the **[Details]** tab with RPCS printer driver.

- Under Windows 2000/Windows XP and Windows NT 4.0, **[Enable bidirectional support]** must be selected and **[Enable printer pooling]** must not be selected on the **[port]** tab with RPCS printer driver.

❖ When connecting with the network

- The printer must be set to bidirectional transmission.
- SmartNetMonitor for Client included on the CD-ROM must be installed, and the TCP/IP protocol must be used.
- Under Windows 95/98/Me, **[Enable bidirectional support for this printer]** must be selected in **[Spool Settings...]** on the **[Details]** tab with RPCS printer driver.
- Under Windows 2000/Windows XP and Windows NT 4.0, **[Enable bidirectional support]** must be selected and **[Enable printer pooling]** must not be selected on the **[port]** tab with RPCS printer driver.
- Under Windows NT 4.0, specified IP address in the Microsoft TCP/IP print is used.

❖ When connecting with IEEE 1394

- The printer must be connected to the IEEE 1394 connector of a computer using the IEEE 1394 interface cable.
- **[Activate]** is selected in the SCSI print of IEEE 1394 and **[Activate]** is selected in the Bidi-SCSI print.
- Under Windows 2000/Windows XP and Windows NT 4.0, **[Enable bidirectional support]** must be selected and **[Enable printer pooling]** must not be selected on the **[port]** tab with RPCS printer driver.

❖ When connecting with USB

The printer must be connected to the USB connector of a computer using the USB interface cable.



💡 Cautions when connecting the USB interface cable and the IEEE 1394 interface cable

💡 Limitation

- Do not unplug the cable while printing. Do not turn off the printer power while printing or during bidirectional transmission.



Macintosh - Installing the PostScript 3 Printer Driver

It is necessary to install a printer driver and a PPD file to print from a Macintosh. Follow these steps to install a printer driver and a PPD file on Macintosh running the 8.6 operating system or later up to 9.1.

- 1** Insert the CD-ROM into the CD-ROM drive.
- 2** Double-click the CD-ROM icon.
- 3** Double-click the [PS DRIVER] folder.
- 4** Double-click the folder of the language you use.
- 5** Open [DISK1] and double-click the installer icon.

The PostScript 3 printer driver installer window appears.

- 6** Follow the instructions on the screen.
- 7** Double-click [Extensions] in [System Folder].
- 8** Double-click [Printer Descriptions].
- 9** Double-click the CD-ROM icon on the desktop.
- 10** Double-click [DISK1] in the folder of the language you use.
- 11** Drag the PPD file into [Printer Descriptions] in [Extensions] in [System Folder].
- 12** Drag the plugin file into [Printer Descriptions] in [Extensions] in [System Folder].
- 13** Restart the Macintosh.

Setting up the PPD file

Preparation

Make sure that the machine is connected to an AppleTalk network before performing the following procedure.

- 1** On the [Apple] menu, select [Chooser].
- 2** Click the [Adobe PS] icon.
- 3** In the [Select a PostScript Printer:] list, click the name of the machine you want to use.
- 4** Click [Setup].

5 Click the printer description file you want to use, and then click **[Select]**.

The PPD file is set up, and the **[Adobe PS]** icon appears at the left of the machine name in the list. Next, follow the procedure on p.65 “Setting up options” to make the option settings, or close the **[Chooser]** dialog box.

Setting up options

1 On the **[Apple]** menu, select **[Chooser]**.**2** Click the **[Adobe PS]** icon.**3** In the **[Select the PostScript Printer:]** list, click the name of the machine you want to use, and then click **[Setup]**.**4** Click **[Configure]**.

A list of options appears.

5 Select the option you want to set up and select the appropriate setting for it. **Note**

- If the option you want to set up is not displayed, the PPD file might not be set up correctly. Check the name of the PPD file shown in the dialog box.

6 Click **[OK]**.

The list of options closes.

7 Click **[OK]**.

The **[Chooser]** dialog box appears.

8 Close the **[Chooser]** dialog box. **Reference**

For information about installing the Printer Utility for Mac, see the PostScript 3 Operating Instructions Supplement.

Installing the Printer Driver Using USB

This section describes basic instructions for installing the printer drivers using USB. The printer drivers can be installed from the provided CD-ROM.

Important

- Be sure that all other applications are closed and that the computer is not currently making prints before installation.

Windows 98/Me - Installing the Printer Driver Using USB

The procedure below takes Windows 98 as an example. The procedure for Windows Me may be slightly different.

When the USB cable is used for the first time, the "plug and play" function starts and **[New Hardware Found]**, **[Device Driver Wizard]** or **[Found New Hardware Wizard]** dialog box appears depending on the system used.

If the printer driver is already installed, the "plug and play" is displayed, and the printer with its port directed to the USB cable is added to the "Printers" folder.

- 1** Click **[Next>]**.
- 2** Select **[Search for the best driver for your device. {Recommended}.]**, and then click **[Next>]**.
- 3** Check **[Specify a location:]**, and then click **[Browse...]**.
The **[Browse for Folder]** dialog box appears.
- 4** Insert the CD-ROM provided into the CD-ROM drive.
When Auto Run starts, click **[Exit]**.

Note

- If you want to inactivate Auto Run, press **[Shift]** when inserting the CD-ROM into the drive and keep it pressed until the computer completes transmission to the drive.

- 5** Select the drive where the printer driver is located according to the operating system used, and then click **[Next>]**.
If the CD-ROM drive is D, the folder will be "D:\Drivers\USB-PRINT\WIN98ME".
- 6** Confirm the printer driver location, and then click **[Next>]**.
"USB Printing Support" will be installed.

- 7** Click **[Finish]**.

- 8** Follow the "plug and play" on the screen to install the printer drivers.

When the installation is complete, the printer with its port directed to "USB00n" appears on the **[Printers]** folder. ("n" is the number of printers connected.)

Windows 2000/Windows XP-Installing the Printer Driver Using USB

! Limitation

- ❑ Installing a printer driver requires the Administrators permission. When you install a printer driver, log on using an account that has the Administrators permission.

When the USB cable is used for the first time, the **[Found New Hardware Wizard]** dialog box appears, and Windows 2000/Windows XP's **[USB Printing Support]** will be installed automatically.

If the printer driver is already installed, the "plug and play" is displayed, and the printer with its port directed to the USB cable is added to the "Printers"^{*1} folder. With Windows XP, even if the printer driver has already been installed, **[Found New Hardware Wizard]** may start when connecting the printer and the computer with the USB cable for the first time. In this case, install the printer driver by following the procedure below.

1 Install the printer driver by referring to the instructions for installing the printer driver with Parallel/Ethernet connection.

When installation is complete, the printer with its port directed to "USB00n" appears on the **[Printers]**^{*1} folder. ("n" is the number of printers connected.)

^{*1} With Windows XP, the folder is **[Printers and Faxes]**.

Macintosh-Creating a Desktop Printer icon

To use a printer connected by USB, create a Desktop Printer icon.

- 1 Install the printer driver. For more information about how to install the printer driver, see p.58 "Installing the PostScript Printer Driver".
- 2 Double-click **[Desktop Printer Utility]** in the **[AdobePS Components]** folder.
- 3 Select **[AdobePS]** in **[With:]** and **[Printer (USB)]** in **[Create Desktop]**, and then click **[OK]**.
- 4 Click **[Change]** in **[USB Printer Selection]**.
- 5 Select the model you are using in **[Select a USB Printer:]**, and then click **[OK]**.
- 6 Click **[Auto Setup]** in **[PostScript™ Printer Description (PPD) File]**.
- 7 Click **[Create]**.
- 8 Enter the printer name, and then click **[Save]**.

The printer icon appears on the desktop.

- 9 Exit the Desktop Printer Utility.

Installing the Printer Driver Using IEEE 1394

This section gives basic instructions for installing the printer drivers using IEEE 1394. The printer drivers can be installed from the CD-ROM provided.

Important

- Be sure that all other applications are closed and that the computer is not printing before installation.

Printing with SCSI Print

Printing using a SCSI print device with the optional 1394 Interface Unit is possible under Windows 2000 and Windows XP.

Important

- Do not connect new IEEE 1394 or USB devices to the printer or turn on the printer while installing the printer driver.
- Before uninstalling the printer driver, be sure to disconnect the 1394 interface cable from the computer.
- "SCSI print" must be set active from the control panel. For more information, see p.45 "IEEE 1394 Configuration".

Note

- This machine cannot receive print data from more than one computer at the same time. If you send data from your computer when data is being received from another computer, a message may appear on the computer display.

Installing the Printer Driver

Note

- If [**Found New Hardware Wizard**] appears every time the computer is started or the cable is connected with Windows 2000/Windows XP, inactivate the device. See p.71 "Inactivating the Device". If you want to install another printer driver after setting the "1394_00n" port, select the "1394_00n" port by following the procedures of installing a printer driver.
- When the printer connected via the 1394 Interface Unit is installed properly, the appearance of the icon in the printer folder changes according to whether the cable is plugged in or not.

Windows 2000

- 1** Connect the printer and the computer using the IEEE 1394 interface cable.
- 2** In the [Found New Hardware Wizard] dialog box, and then click [Next>].
- 3** When the [This wizard will complete the installation for this Device: Unknown] message appears, select [Optional search locations:], and then click [Next>].
- 4** When the [Locate Driver Files] message appears, select the [Optional search locations.] check box, and then select [Specify a location], and then click [Next>].
- 5** Hold down the left **[SHIFT]** key and insert the CD-ROM into the CD-ROM drive.

Keep the left **[SHIFT]** key held down until the computer has finished accessing the CD-ROM.

If the Auto Run program starts, click **[Cancel]**, and then **[Exit]**.

- 6** Click **[Browse]**.
- 7** Select the printer driver that you want to use. The following are locations where printer drivers are stored:
 - RPCS
 \DRIVERS\RPCS\WIN2000\DISK1
 - PCL6
 \DRIVERS\PCL6\WIN2000\DISK1
 - PCL5e
 \DRIVERS\PCL5e\WIN2000\DISK1
 - PostScript 3
 \DRIVERS\PS3\WIN2000\DISK1

8 Click **[Open]**.

9 Click **[OK]**.

A printer model selection dialog box appears.

10 Follow the instructions on the screen.

 **Note**

- During installation, the **[Digital Signature Not Found]** dialog box may appear. In this case, click **[Yes]** to continue the installation.
- If the printer driver is already installed, the printer icon is automatically added to the **[Printer]** folder. In such a case, installation of the printer driver is not necessary.
- When the installation is complete, the printer with its port directed to "1394_00n" appears on the **[Printers]** folder. ("n" is the number of printers connected.)

Windows XP

- 1** Connect the printer and the computer using the IEEE 1394 interface cable.
- 2** In the **[Found New Hardware Wizard]** dialog box, confirm that **[This wizard helps you install software for: (printer name)]** is displayed, and select **[Install from a list on specific location (Advanced)]**, and then click **[Next>]**.
- 3** When the **[Please choose your search and installation option.]** messages appears, select the **[Search for the best driver in these locations.]** check box, and then select the **[Include this location in the search:]** check box, and then select the **[Include this location in the search:]** check box.
- 4** Install the printer driver following the same procedures as steps **5-10** in Windows 2000.

 **Note**

- During installation in Windows XP, the **[Hardware Installation]** dialog box may appear. In this case, click **[Continue Anyway]** to continue the installation.
- When the installation is complete, the printer with its port directed to "1394_00n" appears on the **[Printers and Faxes]** folder. ("n" is the number of printers connected.)
- If the printer driver is already installed, the printer icon is automatically added to the **[Printer]** folder. In this case, installation of the printer driver is not necessary.
- Even if the printer driver has already been installed, **[Found New Hardware Wizard]** may start when connecting the printer and the computer with the IEEE 1394 interface cable for the first time. In this case, install the printer driver by following the procedure.

Printing with IP over 1394

You can print by setting the IP address for this machine and the computer on which Windows XP is installed.

Preparation

"IP over 1394" must be set on the control panel and an IP address for the IEEE 1394 must be specified.

For more information about how to make printer settings, see p.45 "IEEE 1394 Configuration".

Limitation

- When using the IEEE 1394 (IP over 1394) interface in a network, the Ethernet interface cannot be used in the same network.

Note

- The maximum number of simultaneous print requests when connecting with IP over 1394 includes the print requests from the Ethernet interface. For more information, see the Network Printing Guide.

Installing the Printer Driver

To Print using Standard TCP/IP port. For more information about Standard TCP/IP port settings, see Network Printing Guide.

.....

Inactivating the Device

- ❖ When [Add New Hardware Wizard] starts every time you restart the computer with an operating system, which does not support SCSI print or plug in or out the cable, inactivate the device by following procedures.

- Windows Me
 - ① In the [Add New Hardware Wizard] dialog box, confirm that [Windows has found the following new Hardware: IEEE SBP-2 Device] is displayed, and select [Recommended search for a better driver [Recommended]], and then click [Next>].
 - ② When the [Windows was unable to locate the software for this device.] message appears, click [Finish].

❖ If you do not want to install the printer when [Found New Hardware Wizard] starts with an operating system, which supports SCSI print, inactivate the device by following the procedures.

- Windows XP

- ① In the [Found New Hardware Wizard] dialog box, confirm that [This wizard helps you install software for: Unknown] is displayed, and select [Install from a list on specific location (Advanced)], and then click [Next>].
- ② When the [Please choose your search and installation option.] message appears, remove all the selections from [Search for the best driver in these locations.], and then click [Next>].
- ③ When the [The wizard could not find the software on your computer for..] message appears, click [OK].
- ④ When the [Cannot Install this Hardware] message appears, select the [Don't prompt again to install the software] check box, and then click [Finish].

- Windows 2000

- ① In [Found New Hardware Wizard] dialog box, and then click [Next>].
- ② When the [This wizard will complete the installation for this Device: Unknown] message appears, and select [Search for a suitable driver for my device [recommended]], and then click [Next>].
- ③ When the [Locate Driver Files] message appears, remove all the selections from [Optional search locations.], and then click [Next>].
- ④ When the [Driver Files Search Results] message appears, select the [Disable the device. The Add/Remove Hardware Wizard in the control Panel can be able to complete the driver installations.] check box, and then click [Finish].

❖ When [Found New Hardware Wizard] appears every time you restart the computer with an operating system which does not support IP over 1394, plug in or take out the cable, inactivate the device with the following procedure.

- Windows 2000

- ① In [Found New Hardware Wizard] dialog box, and then click [Next>].
 - ② When the [This wizard will complete the installation for this Device:] message appears and "IP over 1394" appears select [Search for a suitable driver for my device [recommended]], and then click [Next>].
 - ③ When the [Locate Driver Files] message appears, remove all the selections from [Optional search locations.], and then click [Next>].
 - ④ When the [Driver Files Search Results] message appears, select the [Disable the device. The Add/Remove Hardware Wizard in the control Panel can be able to complete the driver installations.] check box, and then click [Finish].
-

Installing the SmartNetMonitor for Client/Admin

! Limitation

- ❑ If your system is Windows 2000/Windows XP or Windows NT 4.0, installing software by Auto Run requires Administrators permission. When you install a printer driver by Auto Run, log on using an account that has Administrators permission.

1 Close all applications that are running.

2 Insert the CD-ROM into the CD-ROM drive.

Auto Run will start the installer.

3 Select a language to change the interface language, and then click **[OK]**.

The following languages are available: Cestina (Czech), Dansk (Danish), Deutsch (German), English (English), Espanol (Spanish), Francais (French), Italiano (Italian), Magyar (Hungarian), Nederlands (Dutch), Norsk (Norwegian), Polski (Polish), Portugues (Portuguese), Suomi (Finnish), Svenska (Swedish)

Default interface language is English.

4 Select **[SmartNetMonitor for Client/Admin]**.

5 The software license agreement appears in the **[License Agreement]** dialog box.

After reading through all of the contents, click **[I accept the agreement]** to agree with the license agreement, and then click **[Next]**.

6 Select the program you want to install when the "Select Program" dialog box appears.

7 Follow the instructions on the screen.

Installing the Agfa Monotype Font Manager 2000

! Limitation

- ❑ If your system is Windows 2000/Windows XP or Windows NT 4.0, installing software by Auto Run requires Administrators permission. When you install a printer driver by Auto Run, log on using an account that has Administrators permission.

1 Close all applications that are running.

2 Insert the CD-ROM into the CD-ROM drive.

4 Auto Run will start the installer.

3 Select a language to change the interface language, and then click [OK].

The following languages are available: Cestina (Czech), Dansk (Danish), Deutsch (German), English (English), Espanol (Spanish), Francais (French), Italiano (Italian), Magyar (Hungarian), Nederlands (Dutch), Norsk (Norwegian), Polski (Polish), Portugues (Portuguese), Suomi (Finnish), Svenska (Swedish)

Default interface language is English.

4 Select [Agfa Monotype Font Manager 2000].

5 Follow the instructions on the screen.

Using Adobe PageMaker Version 6.0 or 6.5

If you use the printer under Windows 95/98/Me, Windows 2000/Windows XP, Windows NT 4.0 with Adobe PageMaker, you need to copy the PPD file to the PageMaker folder.

The PPD file is the file with extension ".ppd". It is in the folder "DRIVERS\PS\WIN9X_ME\ (Language)\DISK1\" on the CD-ROM.

The **[WIN9X_ME]** folder, inside the **[PS]** folder is for the Windows 95/98/Me operating system. Use the folder at this level that is appropriate for the operating system you are using.

The third folder, "(Language)" may be substituted by an appropriate language name.

Copy this file to the PageMaker folder.

For PageMaker 6.0 default installation, the folder is "C:\PM6\RSRC\PPD4", and for PageMaker 6.5 default installation, the directory is "C:\PM65\RSRC\USENGLISH\PPD4". "USENGLISH" may differ depending on your language selection.

Reference

For more information about the language name, see p.52 "Quick Install".

INDEX

1394 Interface Unit Type 4510, 13, 14, 25
1-bin Shift Sort Tray Type 2600, 13, 36
802.11b Interface Unit Type A, 13, 14, 29

A

Active Protocol, 41
AD410, 13, 34
Agfa Monotype Font Manager 2000, 4, 74

B

Basic model printer, 1
Bypass Tray, 6
Bypass Tray Extension, 6

C

Caution, ii
Controller Board, 7
Control Panel, 6, 9
CS380, 13, 38

D

Data In indicator, 9

E

Enter key, 10
Envelope Feeder Type 2600, 12, 17
Error indicator, 9
Escape key, 10

F

Form Feed key, 9
Front Cover, 8
Front Cover Release Buttons, 7
Fusing Unit, 8
Fusing Unit Lock Levers, 8

G

Gateway Address, 49
Guide Board, 8

H

Hard Disk Drive Type 2600, 14, 32

J

Job Reset key, 9

M

Memory Unit TypeB 64MB, 14, 18
Menu key, 9

N

Network Interface Board Type 2610, 13, 21
Network Printing Guide, vi
Network standard model printer, 1

O

On Line key, 9
Options, 11
options, available, 12
options, setting up
 Windows 2000/Windows XP, 60
 Windows 95/98/Me, 59
 Windows NT 4.0, 62
Output Tray, 7
Output Tray Extension, 6

P

PageMaker 6.0 or 6.5, 75
Panel display, 9
Paper Exit Cover, 7
Paper Feed Unit Type 2600, 12, 15
Paper Size Dial, 6
Paper Tray, 7
PCL 5e, 2
 Windows 2000/Windows XP,
 installing, 54
 Windows 95/98/Me, *installing*, 54
 Windows NT 4.0, *installing*, 54
PCL 6, 2
 Windows 2000/Windows XP,
 installing, 54
 Windows 95/98/Me, *installing*, 54
 Windows NT 4.0, *installing*, 54
PostScript 3, 3
 Macintosh, *Install*, 64
 Windows 2000/Windows XP,
 installing, 59
 Windows 95/98/Me, *installing*, 58
 Windows NT 4.0, *installing*, 61

Power Cord, 7
Power indicator, 9
Power Switch, 7
printer driver, 2
Printer Reference, vi

Q

Quick Install, 52
Quick Installation Guide, vi

R

Rear Cover, 7
Registration Roller, 8
RPCS
 Windows 2000/Windows XP,
 installing, 56
 Windows 95/98/Me, installing, 56
 Windows NT 4.0, installing, 56

S

Setup Guide, vi
SmartNetMonitor for Admin, 4, 73
SmartNetMonitor for Client, 4, 73
Standard Tray, 7
Subnet Mask, 49

T

Toner Cartridge, 8
Transfer Roller, 8
Transfer Roller Cover, 8

U

Upper Cover, 7

V

Ventilator, 7

W

Warning, ii
Windows 2000/Windows XP
 PCL 5e, installing, 54
 PCL 6, installing, 54
 PostScript 3, installing, 59
 RPCS, installing, 56
 setting up options, 60
Windows 95/98/Me
 PCL 5e, installing, 54
 PCL 6, installing, 54
 PostScript 3, installing, 58
 RPCS, installing, 56
 setting up options, 59
Windows NT 4.0
 PCL 5e, installing, 54
 PCL 6, installing, 54
 PostScript 3, installing, 61
 RPCS, installing, 56
 setting up options, 62

Notes to users in the United States of America

Notice:

This equipment has been tested and found to comply with the limits for a Class B digital device, pursuant to Part 15 of the FCC Rules. These limits are designed to provide reasonable protection against harmful interference in a residential installation. This equipment generates, uses and can radiate radio frequency energy and, if not installed and used in accordance with the instructions, may cause harmful interference to radio communications.

However, there is no guarantee that interference will not occur in a particular installation. If this equipment does cause harmful interference to radio or television reception, which can be determined by turning the equipment off and on, the user is encouraged to try to correct the interference by one more of the following measures:

Reorient or relocate the receiving antenna.

Increase the separation between the equipment and receiver.

Connect the equipment into an outlet on a circuit different from that to which the receiver is connected.

Consult the dealer or an experienced radio/TV technician for help.

Warning

Changes or modifications not expressly approved by the party responsible for compliance could void the user's authority to operate the equipment.

Caution (in case of 100BaseTX environment):

Properly shielded cables must be used for connections to host computer (and/or peripheral) in order to meet FCC emission limits.

Network interface cable with ferrite core must be used for RF interference suppression.

Declaration of Conformity

Product Name: Laser Printer

Model Number: RICOH LASER AP2610/RICOH LASER AP2610N

Responsible party: Ricoh Corporation

Address: 5 Dedrick Place, West Caldwell, NJ 07006

Telephone number: 973-882-2000

This device complies with part 15 of FCC Rules.

Operation is subject to the following two conditions:

1. This device may not cause harmful interference, and
2. this device must accept any interference received, including interference that may cause undesired operation.

Properly shielded cables must be used for connections to host computer (and/or peripheral) in order to meet FCC emission limits.

Network interface cable with ferrite core must be used for RF interference suppression.

Note to users in Canada

Note:

This Class B digital apparatus complies with Canadian ICES-003.

802.11b Interface Unit TypeA(R-WL11):

This device complies with RSS 210 of Industry Canada.

To prevent radio interference to the licensed service, this device must be operated indoors only and should be kept away from windows to provide maximum shielding.

Remarque concernant les utilisateurs au Canada

Avertissement:

Cet appareil numérique de la classe B est conforme à la norme NMB-003 du Canada.

802.11b Interface Unit TypeA(R-WL11):

Pour empêcher que cet appareil cause du brouillage au service faisant l'objet d'une licence, il doit être utilisé à l'intérieur et devrait être placé loin des fenêtres afin de fournir un écran de blindage maximal. Si le matériel (ou son antenne d'émission) est installé à l'extérieur, il doit faire l'objet d'une licence.

In accordance with IEC 60417, this machine uses the following symbols for the main power switch:

I means POWER ON.

O means POWER OFF.

Operating Instructions

Printer Reference

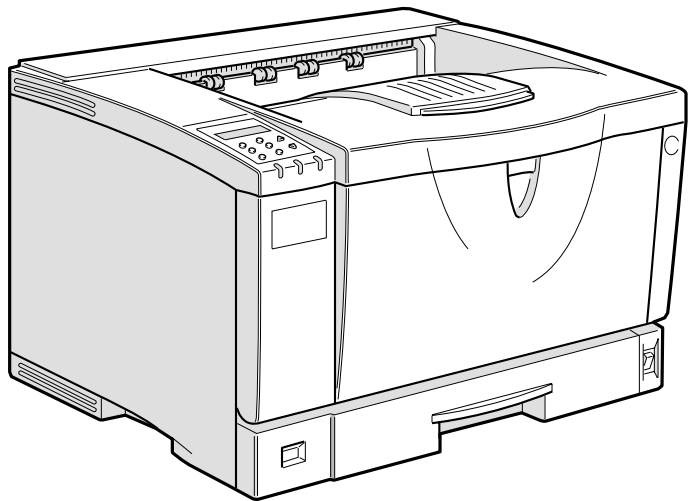

For safety, please read this manual carefully before you use this product and keep it handy for future reference.

Introduction

This manual contains detailed instructions on the operation and maintenance of this machine. To get maximum versatility from this machine all operators should carefully read and follow the instructions in this manual. Please keep this manual in a handy place near the machine.

Please read "Safety Information" in this manual before using this machine. It contains important information related to USER SAFETY and PREVENTING EQUIPMENT PROBLEMS.

Important

Contents of this manual are subject to change without prior notice. In no event will the company be liable for direct, indirect, special, incidental, or consequential damages as a result of handling or operating the machine.

Caution:

Use of controls or adjustment or performance of procedures other than those specified in this manual might result in hazardous radiation exposure.

Do not attempt any maintenance or troubleshooting other than that mentioned in this manual. This printer contains a laser beam generator and direct exposure to laser beams can cause permanent eye damage.

Two kinds of size notation are employed in this manual. With this machine refer to the inch version.

For good print quality, the supplier recommends that you use genuine toner from the supplier.

The supplier shall not be responsible for any damage or expense that might result from the use of parts other than genuine parts from the supplier with your office products.

Trademarks

Microsoft, Windows and Windows NT are registered trademarks of Microsoft Corporation in the United States and/or other countries.

Novell, Netware, NDS are registered trademarks of Novell, Inc.

PostScript is a registered trademark of Adobe Systems, Incorporated.

PCL is a registered trademark of Hewlett-Packard Company.

AppleTalk, Apple, Macintosh, TrueType and LaserWriter are registered trademarks of Apple Computer, Incorporated.

IPS-PRINT Printer Language Emulation Copyright© 1999-2000 Oak Technology, Inc., All rights reserved.

Ethernet is a registered trademark of Xerox Corporation.

Other product names used herein are for identification purposes only and might be trademarks of their respective companies. We disclaim any and all rights in those marks.

- The product name of Windows[®] 95 is Microsoft[®] Windows[®] 95.
- The product name of Windows[®] 98 is Microsoft[®] Windows[®] 98.
- The product name of Windows[®] Me is Microsoft[®] Windows[®] Millennium Edition (Windows Me).
- The product names of Windows[®] 2000 are as follows:
 - Microsoft[®] Windows[®] 2000 Advanced Server
 - Microsoft[®] Windows[®] 2000 Server
 - Microsoft[®] Windows[®] 2000 Professional
- The product names of Windows[®] XP are as follows:
 - Microsoft[®] Windows[®] XP Professional
 - Microsoft[®] Windows[®] XP Home Edition
- The product names of Windows NT[®] 4.0 are as follows:
 - Microsoft[®] Windows NT[®] Server 4.0
 - Microsoft[®] Windows NT[®] Workstation 4.0

Notes:

Some illustrations in this manual might be slightly different from the machine. Certain options might not be available in some countries. For details, please contact your local dealer.

Manuals for This Printer

Manuals for This Printer

The following manuals describe the operational procedures and maintenance of this machine.

To enhance safe and efficient operation of this printer, all users should read and follow the instructions carefully.

❖ **Quick Installation Guide**

Describes how to install the printer.

❖ **Setup Guide**

Provides information about setting up the printer and its options. This manual is provided as a printed manual, and also on the CD-ROM labeled "Operating Instructions".

❖ **Printer Reference (this manual)**

Provides information about using the printer and its options. This manual provided on the CD-ROM labeled "Operating Instructions".

❖ **Network Printing Guide**

Provides information about setting up and using the printer in a network environment. This manual provided on the CD-ROM labeled "Operating Instructions".

❖ **PostScript 3 Operating Instructions Supplement**

Describes the menus and features for the PostScript 3 printer driver. This manual provided on the CD-ROM labeled "Operating Instructions".

 **Note**

- ❑ There are three CD-ROMs that come with this printer. "Operating Instructions", "Printer Drivers and Utilities", and "Document Management Utility".
- ❑ Concerning UNIX information, please visit our Web site or consult your authorized reseller.

How to Read This Manual

Symbols

In this manual, the following symbols are used:

 **WARNING:**

This symbol indicates a potentially hazardous situation which, if instructions are not followed, could result in death or serious injury.

 **CAUTION:**

This symbol indicates a potentially hazardous situation which, if instructions are not followed, may result in minor or moderate injury or damage to property.

* The statements above are notes for your safety.

 **Important**

If this instruction is not followed, paper might be misfed, originals might be damaged, or data might be lost. Be sure to read this.

 **Preparation**

This symbol indicates the prior knowledge or preparations required before operating.

 **Note**

This symbol indicates precautions for operation, or actions to take after misoperation.

 **Limitation**

This symbol indicates numerical limits, functions that cannot be used together, or conditions in which a particular function cannot be used.

 **Reference**

This symbol indicates a reference.

[]

Keys that appear on the machine's panel display.

Keys and buttons that appear on the computer's display.

[]

Keys built into the machine's control panel.

Keys on the computer's keyboard.

TABLE OF CONTENTS

1. Setting Up the Printer Driver and Canceling a Print Job

PCL 6/5e - Accessing the Printer Properties	1
Windows 95/98/Me - Accessing the Printer Properties	1
Windows 2000/Windows XP - Accessing the Printer Properties.....	2
Windows NT 4.0 - Accessing the Printer Properties	4
RPCS - Accessing the Printer Properties.....	6
Windows 95/98/Me - Accessing the Printer Properties	6
Windows 2000/Windows XP - Accessing the Printer Properties.....	7
Windows NT 4.0 - Accessing the Printer Properties	9
PostScript - Setting Up for Printing	11
Windows 95/98/Me - Accessing the Printer Properties	11
Windows 2000/Windows XP - Accessing the Printer Properties.....	12
Windows NT 4.0 - Accessing the Printer Properties	14
Macintosh - Setting Up for Printing	16
Canceling a Print Job.....	17
Windows 95/98/Me, Windows 2000, Windows XP, Windows NT 4.0 - Canceling a Print Job	17
Macintosh - Canceling a Print Job	18

2. Uninstalling the Printer Driver and Software

Uninstalling the PCL 6/5e Printer Driver	19
Windows 95/98/Me - Uninstalling the PCL 6/5e Printer Driver.....	19
Windows 2000/Windows XP - Uninstalling the PCL 6/5e Printer Driver	19
Windows NT 4.0 - Uninstalling the PCL 6/5e Printer Driver.....	20
Uninstalling the RPCS Printer Driver.....	21
Windows 95/98/Me - Uninstalling the RPCS Printer Driver.....	21
Windows 2000/Windows XP - Uninstalling the RPCS Printer Driver	21
Windows NT 4.0 - Uninstalling the RPCS Printer Driver.....	22
Uninstalling the PostScript Printer Driver.....	23
Windows 95/98/Me - Uninstalling the PostScript Printer Driver	23
Windows 2000/Windows XP - Uninstalling the PostScript Printer Driver	23
Windows NT 4.0 - Uninstalling the PostScript Printer Driver	24
Macintosh - Uninstalling the PostScript Printer Driver	24

3. Paper and Other Media

Paper and Other Media Supported by This Printer	25
Paper Types and Sizes	25
Paper Recommendations.....	33
Printable Area	36
Loading Paper and Other Media	37
Loading Paper in the Paper Tray	37
Loading Paper in the Bypass Tray	40
Loading Paper in the Optional Paper Tray	44
Loading Envelopes.....	45

4. Sample Print/Locked Print

Sample Print	51
Printing a Sample Print File.....	51
Deleting a Sample Print File.....	53
Checking the Error Log	54
Locked Print	56
Printing a Locked Print File	56
Deleting the Locked Print File	58
Checking the Error Log	59

5. Troubleshooting

Error & Status Messages on the Control Panel	61
Getting Printer Information over the Network.....	69
Printer Does Not Print	76
Other Printing Problems	79
Removing Misfed Paper	82
When "Remove Misfeed Paper Tray" Appears	82
When "Remove Misfeed Internal Path/Open Front Cover" Appears.....	83
When "Remove Misfeed Paper Exit Cover" Appears.....	84
When "Remove Misfeed Duplex Unit" Appears	87
When "Remove Misfeed Mailbox" Appears	89
When "Remove Misfeed Upper Tray Unit" Appears	89
Replacing the Toner Cartridge	90
Cleaning and Adjusting the Printer	93
Cleaning the Friction Pad.....	93
Cleaning the Paper Feed Roller.....	94
Cleaning the Registration Roller	96
Adjusting the Image Density	97
Adjusting the Registration of the Trays	98

6. Making Printer Settings with the Control Panel

Menu Chart	101
Accessing the Main Menu	104
Paper Input Menu	106
Paper Input Parameters	106
Changing the Paper Input Menu	108
List/Test Print Menu	110
List/Test Print Parameters.....	110
Printing a Configuration Page	110
Interpreting the Configuration Page	112
Maintenance Menu	114
Maintenance Menu Parameters	115
Changing the Maintenance Menu	117

System Menu	124
System Parameters.....	124
Changing the System Menu	128
Host Interface Menu	130
Host Interface Parameters	130
Changing the Host Interface Menu	135
PCL Menu	137
PCL Parameters.....	137
Changing the PCL Menu.....	139
Language Menu	141
Changing the Language Menu	141

7. Appendix

Replacing Parts	143
MAINTENANCE KIT Type 2600	144
Replacing the Friction Pad	145
Replacing the Paper Feed Rollers	146
Replacing the Transfer Roller	147
Replacing the Fusing Unit.....	149
Collate and Shift Collate	151
Spool Printing.....	152
Memory Capacity and Paper Size	153
Setting of the “Frame Priority”	153
Setting of the “Font Priority”	154
Moving and Transporting the Printer	155
Moving the Printer	155
Specifications	157
Mainframe	157
Options.....	160
Consumables.....	164
Information about Installed Software	165
expat	165
JPEG LIBRARY	165
NetBSD	166
INDEX.....	168

1. Setting Up the Printer Driver and Canceling a Print Job

PCL 6/5e - Accessing the Printer Properties

Windows 95/98/Me - Accessing the Printer Properties

Changing the default printer settings

- 1** Click **[Start]** on the taskbar, point to **[Settings]**, and then click **[Printers]**.
The **[Printers]** window appears.
- 2** Click to select the icon of the printer whose default settings you want to change.
- 3** On the **[File]** menu, click **[Properties]**.
The Printer Properties appear.
- 4** Make any settings you require and click **[Apply]**.
 **Note**
 - With some applications, the printer driver's settings are not used, and the application's own default settings are applied.
- 5** Click **[OK]**.

Making printer settings from an application

To make the printer settings for a specific application, open the **[Printer Properties]** dialog box from that application. The following example describes how to make settings for the WordPad application that comes with Windows 95/98/Me.

-  **Note**
- The actual procedure you should follow to open the **[Printer Properties]** dialog box may differ depending on the application. For more information, see the documentation that comes with the application you are using.
 - Any settings you make in the following procedure are valid for the current application only.
- 1** On the **[File]** menu, click **[Print]**.
The **[Print]** dialog box appears.
 - 2** Select the printer you want to use in the **[Name]** list box, and then click **[Properties]**.
The **[Printer Properties]** dialog box appears.

3 Make any settings you require and click [OK].

4 Click [OK] to start printing.

1

Windows 2000/Windows XP - Accessing the Printer Properties

Changing the default printer settings - Printer Properties

 **Limitation**

- Changing the setting of the printer requires Manage Printers permission. Members of the Administrators and Power Users groups have Manage Printers permission by default. When you set up options, log on using an account that has Manage Printers permission.

1 Click [Start] on the taskbar, point to [Settings], and then click [Printers].

The [Printers] window appears.

 **Note**

- With Windows XP, access the [Printers and Faxes] window from [Start] on the taskbar.

2 Click to select the icon of the printer whose default setting you want to change.

3 On the [File] menu, click [Properties].

The Printer Properties appear.

4 Make any settings you require and click [OK].

 **Note**

- Settings you make here are used as the default settings for all applications.

5 Click [OK].

Changing the default printer settings – Printing Preferences Properties

 **Limitation**

- Changing the setting of the printer requires Manage Printers permission. Members of the Administrators and Power Users groups have Manage Printers permission by default. When you set up options, log on using an account that has Manage Printers permission.

1 Click [Start] on the taskbar, point to [Settings], and then click [Printers].

The [Printers] window appears.

2 Click to select the icon of the printer whose default settings you want to change.

3 On the [File] menu, click [Printing Preferences...].

The Printing Preferences Properties appears.

4 Make any settings you require and click [Apply].

 **Note**

Settings you make here are used as the default settings for all applications.

5 Click [OK].

Making printer settings from an application

To make the printer settings for a specific application, open the [Print] dialog box from that application. The following example describes how to make settings for the WordPad application that comes with Windows 2000/Windows XP.

 **Note**

The actual procedures you should follow to open the [Print] dialog box may differ depending on the application. For more information, see the documentation that comes with the application you are using.

Any settings you make in the following procedure are valid for the current application only.

1 On the [File] menu, click [Print...].

The [Print] dialog box appears.

2 Select the printer you want to use in the [Select Printer] box.

Click the tab that you want to change its print setting.

 **Note**

With Windows XP, click [Preference] to open the Printer Preference window.

3 Make any settings you require and click [Apply].

 **Note**

With Windows XP, make any settings you require and click [OK].

4 Click [Print] to start printing.

Windows NT 4.0 - Accessing the Printer Properties

1

Changing the default printer settings - Printer Properties

 **Limitation**

- Changing the setting of the printer requires Full Control access permission. Members of Administrators, Server Operators, Print Operators, and Power Users groups have Full Control permission by default. When you set up options, log on using an account that has Full Control permission.

1 Click **[Start]** on the taskbar, point to **[Settings]**, and then click **[Printers]**.

The **[Printers]** window appears.

2 Click to select the icon of the printer whose default settings you want to change.

3 On the **[File]** menu, click **[Properties]**.

The Printer Properties appears.

4 Make any settings you require and click **[OK]**.

 **Note**

- Settings you make here are used as the default settings for all applications.

Changing the default printer settings – Default Document Properties

 **Limitation**

- Changing the setting of the printer requires Full Control access permission. Members of the Administrators, Server Operators, Print Operators, and Power Users groups have Full Control permission by default. When you set up options, log on using an account that has Full Control permission.

1 Click **[Start]** on the taskbar, point to **[Settings]**, and then click **[Printers]**.

The **[Printers]** window appears.

2 Click to select the icon of the printer whose default settings you want to change.

3 On the **[File]** menu, click **[Document Defaults]**.

The Default Document Properties appear.

4 Make any settings you require and click **[OK]**.

 **Note**

- Settings you make here are used as the default settings for all applications.

Making printer settings from an application

To make the printer settings for a specific application, open the **[Printer Properties]** dialog box from that application. The following example describes how to make settings for the WordPad application that comes with Windows NT 4.0.

 **Note**

- The actual procedure you should follow to open the **[Printer Properties]** dialog box may differ depending on the application. For more information, see the documentation that comes with the application you are using.
- Any settings you make in the following procedure are valid for the current application only.

1 On the **[File]** menu, click **[Print]**.

The **[Print]** dialog box appears.

2 Select the printer you want to use in the **[Name]** list box, and then click **[Properties]**.

The Printer Properties appears.

3 Make any settings you require and click **[OK]**.

Click **[OK]** to start printing.

RPCS - Accessing the Printer Properties

1

Windows 95/98/Me - Accessing the Printer Properties

Changing the default printer settings

1 Click **[Start]** on the taskbar, point to **[Settings]**, and then click **[Printers]**.

The **[Printers]** window appears.

2 Click to select the icon of the printer whose default settings you want to change.

3 On the **[File]** menu, click **[Properties]**.

The printer properties appear.

4 Make any settings you require and click **[Apply]**.

 **Note**

- With some applications, the printer driver's settings are not used, and the application's own default settings are applied.

5 Click **[OK]**.

Making printer settings from an application

To make the printer settings for a specific application, open the **[Printer Properties]** dialog box from that application. The following example describes how to make settings for the WordPad application that comes with Windows 95/98/Me.

 **Note**

- The actual procedure you should follow to open the **[Printer Properties]** dialog box may differ depending on the application. For more information, see the documentation that comes with the application you are using.
- Any settings you make in the following procedure are valid for the current application only.

1 On the **[File]** menu, click **[Print]**.

The **[Print]** dialog box appears.

2 Select the printer you want to use in the **[Name]** list box, and then click **[Properties]**.

The **[Printer Properties]** dialog box appears.

3 Make any settings you require and click **[OK]**.

4 Click **[OK]** to start printing.

Windows 2000/Windows XP - Accessing the Printer Properties

Changing the default printer settings - Printer Properties

1

Limitation

- Changing the setting of the printer requires Manage Printers permission. Members of the Administrators and Power Users groups have Manage Printers permission by default. When you set up options, log on using an account that has Manage Printers permission.

1 Click **[Start]** on the taskbar, point to **[Settings]**, and then click **[Printers]**.

The **[Printers]** window appears.

Note

- With Windows XP, access the **[Printers and Faxes]** window from **[Start]** on the taskbar.

2 Click to select the icon of the printer whose default settings you want to change.

3 On the **[File]** menu, click **[Properties]**.

The Printer Properties appears.

4 Make any settings you require and click **[Apply]**.

Note

- Settings you make here are used as the default settings for all applications.

5 Click **[OK]**.

Changing the default printer settings – Printing Preferences Properties

Limitation

- Changing the setting of the printer requires Manage Printers permission. Members of the Administrators and Power Users groups have Manage Printers permission by default. When you set up options, log on using an account that has Manage Printers permission.

1 Click **[Start]** on the taskbar, point to **[Settings]**, and then click **[Printers]**.

The **[Printers]** window appears.

2 Click to select the icon of the printer whose default settings you want to change.

3 On the **[File]** menu, click **[Printing Preferences...]**.

The Printing Preferences Properties appear.

4 Make any settings you require and click **[Apply]**.

 **Note**

- Settings you make here are used as the default settings for all applications.

5 Click **[OK]**.

Making printer settings from an application

To make the printer settings for a specific application, open the **[Print]** dialog box from that application. The following example describes how to make settings for the WordPad application that comes with Windows 2000.

 **Note**

- The actual procedures you should follow to open the **[Print]** dialog box may differ depending on the application. For more information, see the documentation that comes with the application you are using.
- Any settings you make in the following procedure are valid for the current application only.

1 On the **[File]** menu, click **[Print...]**.

The **[Print]** dialog box appears.

2 Select the printer you want to use in the **[Select Printer]** box.

Click the tab that you want to change its print setting.

 **Note**

- With Windows XP, click **[Preference]** to open the Printer Preference window.

3 Make any settings you require and click **[Apply]**.

 **Note**

- With Windows XP, make any settings you require and click **[OK]**.

4 Click **[Print]** to start printing.

Windows NT 4.0 - Accessing the Printer Properties

Changing the default printer settings - Printer Properties

1

Limitation

- Changing the setting of the printer requires Full Control access permission. Members of Administrators, Server Operators, Print Operators, and Power Users groups have Full Control permission by default. When you set up options, log on using an account that has Full Control permission.

1 Click [Start] on the taskbar, point to [Settings], and then click [Printers].

The [Printers] window appears.

2 Click to select the icon of the printer you want to use.

3 On the [File] menu, click [Properties].

The [Printer Properties] dialog box appears.

4 Make any settings you require and click [OK].

Note

- Settings you make here are used as the default settings for all applications.

Changing the default printer settings – Default Document Properties

Limitation

- Changing the setting of the printer requires Full Control access permission. Members of the Administrators, Server Operators, Print Operators, and Power Users groups have Full Control permission by default. When you set up options, log on using an account that has Full Control permission.

1 Click [Start] on the taskbar, point to [Settings], and then click [Printers].

The [Printers] window appears.

2 Click to select the icon of the printer you want to use.

3 On the [File] menu, click [Document Defaults].

The Default Document Properties appear.

4 Make any settings you require and click [OK].

Note

- Settings you make here are used as the default settings for all applications.

Making printer settings from an application

To make the printer settings for a specific application, open the **[Printer Properties]** dialog box from that application. The following example describes how to make settings for the WordPad application that comes with Windows NT 4.0.

 **Note**

- The actual procedure you should follow to open the **[Printer Properties]** dialog box may differ depending on the application. For more information, see the documentation that comes with the application you are using.
- Any settings you make in the following procedure are valid for the current application only.

1 On the **[File]** menu, click **[Print]**.

The **[Print]** dialog box appears.

2 Select the printer you want to use in the **[Name]** list box, and then click **[Properties]**.

The **[Printer Properties]** dialog box appears.

3 Make any settings you require and click **[OK]**.

4 Click **[OK]** to start printing.

PostScript - Setting Up for Printing

Windows 95/98/Me - Accessing the Printer Properties

1

Changing the default printer settings

 **Note**

- With some applications, the printer driver's settings are not used, and the application's own default settings are applied.

1 Click **[Start]** on the taskbar, point to **[Settings]**, and then click **[Printers]**.

The **[Printers]** window appears.

2 Click to select the icon of the printer whose default settings you want to change.

3 On the **[File]** menu, click **[Properties]**.

The **[Printer Properties]** dialog box appears.

4 Make any settings you require and click **[Apply]**.

5 Click **[OK]**.

Making printer settings from an application

To make the printer settings for a specific application, open the **[Printer Properties]** dialog box from that application. The following example describes how to make settings for the WordPad application that comes with Windows 95/98/Me.

 **Note**

- The actual procedure you should follow to open the **[Printer Properties]** dialog box may differ depending on the application. For more information, see the documentation that comes with the application you are using.
- Any settings you make in the following procedure are valid for the current application only.

1 On the **[File]** menu, click **[Print]**.

The **[Print]** dialog box appears.

2 Select the printer you want to use in the Name list box, and then click **[Properties]**.

The **[Printer Properties]** dialog box appears.

3 Make any settings you require and click **[Apply]**.

4 Click **[OK]** to start printing.

Windows 2000/Windows XP - Accessing the Printer Properties

1

Changing the default printer settings - Printer Properties

 **Limitation**

- Changing the setting of the printer requires Manage Printers permission. Members of the Administrators and Power Users groups have Manage Printers permission by default. When you set up options, log on using an account that has Manage Printers permission.

1 Click **[Start]** on the taskbar, point to **[Settings]**, and then click **[Printers]**.

The **[Printers]** window appears.

 **Note**

- With Windows XP, access the **[Printers and Faxes]** window from **[Start]** on the taskbar.

2 Click to select the icon of the printer whose default settings you want to change.

3 On the **[File]** menu, click **[Properties]**.

The Printer Properties appear.

4 Make any settings you require and click **[Apply]**.

 **Note**

- Settings you make here are used as the default settings for all applications.

5 Click **[OK]**.

Changing the default printer settings – Printing Preferences Properties

 **Limitation**

- Changing the setting of the printer requires Manage Printers permission. Members of the Administrators and Power Users groups have Manage Printers permission by default. When you set up options, log on using an account that has Manage Printers permission.

1 Click **[Start]** on the taskbar, point to **[Settings]**, and then click **[Printers]**.

The **[Printers]** window appears.

2 Click to select the icon of the printer whose default settings you want to change.

3 On the **[File]** menu, click **[Printing Preferences...]**.

The Printing Preferences Properties appears.

4 Make any settings you require and click **[Apply]**.

 **Note**

- Settings you make here are used as the default settings for all applications.

5 Click **[OK]**.

Making printer settings from an application

To make the printer settings for a specific application, open the **[Print]** dialog box from that application. The following example describes how to make settings for the WordPad application that comes with Windows 2000/Windows XP.

 **Note**

- The actual procedures you should follow to open the **[Print]** dialog box may differ depending on the application. For more information, see the documentation that comes with the application you are using.
- Any settings you make in the following procedure are valid for the current application only.

1 On the **[File]** menu, click **[Print...]**.

The **[Print]** dialog box appears.

2 Select the printer you want to use in the **[Select Printer]** box.

Click the tab that you want to change its print setting.

 **Note**

- With Windows XP, click **[Preference]** to open the Printer Preference window.

3 Make any settings you require and click **[Apply]**.

4 Click **[OK]** to start printing.

Windows NT 4.0 - Accessing the Printer Properties

1

Changing the default printer settings - Printer Properties

Limitation

- Changing the setting of the printer requires Full Control access permission. Members of Administrators, Server Operators, Print Operators, and Power Users groups have Full Control permission by default. When you set up options, log on using an account that has Full Control permission.

1 Click **[Start]** on the taskbar, point to **[Settings]**, and then click **[Printers]**.

The **[Printers]** window appears .

2 Click to select the icon of the printer whose default settings you want to change.

3 On the **[File]** menu, click **[Properties]**.

The **[Printer Properties]** dialog box appears.

4 Make any settings you require and click **[OK]**.

Note

- Setting you make here are used as the default settings for all applications.

Changing the default printer settings - Default Document Properties

Limitation

- Changing the setting of the printer requires Full Control access permission. Members of the Administrators, Server Operators, Print Operators, and Power Users groups have Full Control permission by default. When you set up options, log on using an account that has Full Control permission.

1 Click **[Start]** on the taskbar, point to **[Settings]**, and then click **[Printers]**.

The **[Printers]** window appears.

2 Click to select the icon of the printer you want to use.

3 On the **[File]** menu, click **[Document Defaults]**.

The Default Document Properties appear.

4 Make any settings you require and click **[OK]**.

Note

- Settings you make here are used as the default settings for all applications.

Making printer settings from an application

To make the printer settings for a specific application, open the **[Printer Properties]** dialog box from that application. The following example describes how to make settings for the WordPad application that comes with Windows NT 4.0.

 **Note**

- The actual procedure you should follow to open the **[Printer Properties]** dialog box may differ depending on the application. For more information, see the documentation that comes with the application you are using.
- Any settings you make in the following procedure are valid for the current application only.

1 On the **[File]** menu, click **[Print]**.

The **[Print]** dialog box appears.

2 Select the printer you want to use in the **[Name]** list box, and then click **[Properties]**.

The **[Printer Properties]** dialog box appears.

3 Make any settings you require and click **[OK]**.

4 Click **[OK]** to start printing.

Macintosh - Setting Up for Printing

1

Making paper settings from an application

- 1** Open the file you want to print.
- 2** On the [File] menu, click [Page Setup].
The [AdobePS Page Setup] dialog box appears.
- 3** Confirm that the printer you want to use is shown in the [Format for:] box.

 **Note**

- If the printer is not shown in the [Format for:] box, use the pop-up menu to display a list of available printers.

 **Reference**

The actual appearance of the Page Setup depends on the application you are using. See the documentation that comes with the Macintosh for more information.

- 4** From the [Paper:] box, select the paper size.
- 5** Make any settings you require and then click [OK].

Setting up for printing from an application

- 1** Open the file you want to print.
- 2** On the [File] menu, click [Print].
The Printer Settings appears.
- 3** Confirm that the printer is selected in the [Printer :] box.
- 4** Make any settings you require and click [Print] to start printing.

Canceling a Print Job

Windows 95/98/Me, Windows 2000, Windows XP, Windows NT 4.0 - Canceling a Print Job

1

- 1** Double-click the printer icon on the Windows taskbar.

A window appears, showing all the print jobs that are currently queuing to be printed. Check the current status of the job you want to cancel.

- 2** Select the name of the job you want to cancel.

- 3** On the [Document] menu, click [Cancel Printing].

 **Note**

- You can also open the print job queue window by double-clicking the printer icon in the [Printer] window.

- 4** Press [Job Reset] on the control panel.

The message appears on the panel display indicating that the print job is being canceled.

 **Important**

- When the printer is being shared by multiple computers, be careful not to accidentally cancel someone else's print job.

 **Note**

- This procedure cancels the print job that is being processed by the printer. In some cases, the printer may already be processing data for the next series of print jobs following the one currently being output. In this case, the next print jobs are also canceled when you press [Job Reset].
- A print job that contains a large volume of data may take considerable time to stop.

Macintosh - Canceling a Print Job

1

1 Double-click the printer's icon on the desktop.

A window appears, showing all the print jobs that are currently queuing to be printed. Check the current status of the job you want to cancel.

2 Select the name of the job you want to cancel.

3 Click the pause icon, and then click the trash icon.

4 Press **[Job Reset]** on the control panel.

The message appears on the panel display indicating that the print job is being canceled.

 **Important**

- When the printer is being shared by multiple computers, be careful not to accidentally cancel someone else's print job.

 **Note**

- This procedure cancels the print job that is being processed by the printer. In some cases, the printer may already be processing data for the next series of print jobs following the one currently being output. In this case, the next print jobs are also canceled when you press **[Job Reset]**.
- A print job that contains a large volume of data may take considerable time to stop.

2. Uninstalling the Printer Driver and Software

Uninstalling the PCL 6/5e Printer Driver

This section describes how to uninstall the printer driver. The actual procedure may differ depending on the operating system.

Follow one of the appropriate procedures below.

Windows 95/98/Me - Uninstalling the PCL 6/5e Printer Driver

- 1** Close all applications that are currently running.
- 2** Click **[Start]** on the taskbar, point to **[Settings]**, and then click **[Printers]**.
The **[Printers]** window appears.
- 3** Click to select the icon of the printer you want to remove.
- 4** On the **[File]** menu, click **[Delete]**.
A confirmation dialog box appears.
- 5** Click **[Yes]** to uninstall the printer driver.

Windows 2000/Windows XP - Uninstalling the PCL 6/5e Printer Driver

Limitation

- Uninstalling a printer driver requires Manage Printers permission. Members of the Administrators and Power Users groups have Manage Printers permission by default. When you uninstall a printer driver, log on using an account that has Manage Printers permission.

- 1** Close all applications that are currently running.
- 2** Click **[Start]** on the taskbar, point to **[Settings]**, and then click **[Printers]**.
The **[Printers]** window appears.

Note

- With Windows XP, access the **[Printers and Faxes]** window from **[Start]** on the taskbar.

- 3** Click to select the icon of the printer you want to remove.
- 4** On the **[File]** menu, click **[Delete]**.
A confirmation dialog box appears.

5 Click **[Yes]** to uninstall the printer driver.

 **Note**

- Before upgrading the printer driver, restart your computer after uninstalling the old version of the printer driver.

Windows NT 4.0 - Uninstalling the PCL 6/5e Printer Driver

 **Limitation**

- Uninstalling a printer driver requires Full Control access permission. Members of the Administrators, Server Operators, Print Operators, and Power Users groups have Full Control Permission by default. When you install a printer driver, log on using an account that has Full Control permission.

1 Close all applications that are currently running.

2 Click **[Start]** on the taskbar, point to **[Settings]**, and then click **[Printers]**.

The **[Printers]** window appears.

3 Click to select the icon of the printer you want to remove.

4 On the **[File]** menu, click **[Delete]**.

A confirmation dialog box appears.

5 Click **[Yes]** to uninstall the printer driver.

 **Note**

- Before upgrading the printer driver, restart your computer after uninstalling the old version of the printer driver.

Uninstalling the RPCS Printer Driver

This section describes how to uninstall the printer driver. The actual procedure may differ depending on the operating system.

Follow one of the appropriate procedures below.

Windows 95/98/Me - Uninstalling the RPCS Printer Driver



2

- 1** Close all applications that are currently running.
- 2** Click **[Start]** on the taskbar, point to **[Settings]**, and then click **[Printers]**.
The **[Printers]** window appears.
- 3** Click to select the icon of the printer you want to remove.
- 4** On the **[File]** menu, click **[Delete]**.
A confirmation dialog box appears.
- 5** Click **[Yes]** to uninstall the printer driver.

Windows 2000/Windows XP - Uninstalling the RPCS Printer Driver

Limitation

- Uninstalling a printer driver requires Manage Printers permission. Members of the Administrators and Power Users groups have Manage Printers permission by default. When you uninstall a printer driver, log on using an account that has Manage Printers permission.

- 1** Close all applications that are currently running.
- 2** Click **[Start]** on the taskbar, point to **[Settings]**, and then click **[Printers]**.
The **[Printers]** window appears.
 **Note**
 - With Windows XP, access the **[Printers and Faxes]** window from **[Start]** on the taskbar.
- 3** Click to select the icon of the printer you want to remove.
- 4** On the **[File]** menu, click **[Delete]**.
A confirmation dialog box appears.
- 5** Click **[Yes]** to uninstall the printer driver.
 **Note**
 - Before upgrading the printer driver, restart your computer after uninstalling the old version of the printer driver.

Windows NT 4.0 - Uninstalling the RPCS Printer Driver

Limitation

- Uninstalling a printer driver requires Full Control access permission. Members of the Administrators, Server Operators, Print Operators, and Power Users groups have Full Control Permission by default. When you install a printer driver, log on using an account that has Full Control permission.

1 Close all applications that are currently running.

2 Click **[Start]** on the taskbar, point to **[Settings]**, and then click **[Printers]**.

The **[Printers]** window appears.

3 Click to select the icon of the printer you want to remove.

4 On the **[File]** menu, click **[Delete]**.

A confirmation dialog box appears.

5 Click **[Yes]** to uninstall the printer driver.

Note

- Before upgrading the printer driver, restart your computer after uninstalling the old version of the printer driver.

Uninstalling the PostScript Printer Driver

This section describes how to uninstall the PostScript printer driver. The actual procedure may differ depending on the operating system. Follow one of the appropriate procedures below.

Windows 95/98/Me - Uninstalling the PostScript Printer Driver

2

- 1** Close all applications that are currently running.
- 2** Click **[Start]** on the taskbar, point to **[Settings]**, and then click **[Printers]**.
The **[Printers]** window appears.
- 3** Click to select the icon of the printer you want to remove.
- 4** On the **[File]** menu, click **[Delete]**.
A confirmation dialog box appears.
- 5** Click **[Yes]** to uninstall the printer driver.

Windows 2000/Windows XP - Uninstalling the PostScript Printer Driver

Limitation

- Uninstalling a printer driver requires Manage Printers permission. Members of the Administrators and Power Users groups have Manage Printers permission by default. When you uninstall a printer driver, log on using an account that has Manage Printers permission.

- 1** Close all applications that are currently running.
- 2** Click **[Start]** on the taskbar, point to **[Settings]**, and then click **[Printers]**.
The **[Printers]** window appears.

Note

- With Windows XP, access the **[Printers and Faxes]** window from **[Start]** on the taskbar.

- 3** Click to select the icon of the printer you want to remove.
- 4** On the **[File]** menu, click **[Delete]**.
A confirmation dialog box appears.
- 5** Click **[Yes]** to uninstall the printer driver.

Note

- Before upgrading the printer driver, restart your computer after uninstalling the old version of the printer driver.

Windows NT 4.0 - Uninstalling the PostScript Printer Driver

Limitation

- Uninstalling a printer driver requires Full Control access permission. Members of the Administrators, Server Operators, Print Operators, and Power Users groups have Full Control Permission by default. When you uninstall a printer driver, log on using an account that has Full Control permission.

1 Close all applications that are currently running.

2 Click [Start] on the taskbar, point to [Settings], and then click [Printers].

The [Printers] window appears.

3 Click to select the icon of the printer you want to remove.

4 On the [File] menu, click [Delete].

A confirmation dialog box appears.

5 Click [Yes] to uninstall the printer driver.

Note

- Before upgrading the printer driver, restart your computer after uninstalling the old version of the printer driver.

Macintosh - Uninstalling the PostScript Printer Driver

1 Drag the “AdobePS” file from the [Extensions] folder in [System Folder] to [Trash].

2 Drag the PPD file and plug-in file from the [Printer Descriptions] folder in the [Extensions] folder in [System Folder] to [Trash].

3. Paper and Other Media

Paper and Other Media Supported by This Printer

Paper Types and Sizes



This section describes the type, size, feed direction, and maximum amount of paper that can be loaded into each paper tray in this printer.

Important

- ❑ If you use damp or curled paper, a misfeed might occur. In this case, try turning over the paper stack in the paper tray. If there is no improvement, change to paper with less curl.

Note

- ❑ The following symbols and terminology are used to represent the feed direction.

In this manual	On the panel display	Paper feed direction
 ↑ (Feed direction)	A4 (210 × 297) Letter (8 ¹ / ₂ × 11)	Short-edge feed direction
 ↑ (Feed direction)	A4 (297 × 210) Letter (11 × 8 ¹ / ₂)	Long-edge feed direction

- ❑ It is recommended that you load paper of the size and direction you frequently use in the tray selected with “Tray Priority”. For more information about Tray Priority, see p.106 “Paper Input Menu”.
- ❑ When loading paper of the same size in more than one tray, it is recommended that you load paper in the same direction in each tray.

Reference

For more information about loading each type of paper, see p.37 “Loading Paper and Other Media”.

























Important

- ❑ Be sure to set the paper size dial to match the actual paper size loaded in the tray. When the actual paper size is not shown on the dial, set the dial to “✱” and select the paper size using the control panel.
- ❑ For Tray 1, 2 and 3, the dial setting overrides the setting made with the control panel.
- ❑ The optional Envelope Feeder Unit requires the installation of the optional Paper Feed Unit. Up to two Paper Feed Units can be installed to the printer at the same time. The Envelope Feeder Unit must be used in the top-most Paper Feed Unit (Tray2).

 **Note**

- ❑ The printable paper size depends on the memory size of the printer and print data, see p.153 “Memory Capacity and Paper Size”.
- ❑ For more information about the meanings of the abbreviations, see the notes at the bottom of each table.

◆ Input Paper Sizes (Metric version)

	Feed direction	Size (mm)	Bypass Tray	Paper Tray (Tray1)	Paper Feed Unit (Tray 2/3)	Envelope Feeder Unit
A3		297 × 420	○	☆	☆	X
B4 JIS		257 × 364	○	★	★	X
A4		210 × 297	○	☆	☆	X
		297 × 210	○	☆	☆	X
B5 JIS		182 × 257	○	★	★	X
		257 × 182	○	★	★	X
A5		148 × 210	○	X	X	X
		210 × 148	○	☆	★	X
A6		105 × 148	○	X	X	X
11 × 17		279 × 432	○	★	☆	X
Legal (LG, 8 ¹ / ₂ × 14)		216 × 356	○	★	☆	X
Letter (LT, 8 ¹ / ₂ × 11)		216 × 279	○	☆	☆	X
		279 × 216	○	☆	☆	X
5 ¹ / ₂ × 8 ¹ / ₂		140 × 216	○	X	X	X
Executive (Exec., 7 ¹ / ₄ × 10 ¹ / ₂)		184 × 276	○	X	★	X
		276 × 184	○	★	★	X
Folio (8 ¹ / ₄ × 13)		210 × 330	○	★	★	X
Foolscap (F4, 8 ¹ / ₂ × 13)		216 × 330	○	★	★	X
F/GL (8 × 13)		203 × 330	○	★	★	X
Com#10 Env (4 ¹ / ₈ × 9 ¹ / ₂)		104.8 × 241.3	○	X	X	○
C5 Env (6.38 × 9.02)		162 × 229	○	X	X	○
C6 Env (4.49 × 6.38)		114 × 162	○	X	X	○
DL Env (4.33 × 8.66)		110 × 220	○	X	X	○
Monarch Env (3 ⁷ / ₈ × 7 ¹ / ₂)		98.4 × 190.5	○	X	X	○

	Feed direction	Size (mm)	Bypass Tray	Paper Tray (Tray1)	Paper Feed Unit (Tray 2/3)	Envelope Feeder Unit
Custom Size	—	—	○*	X	★**	X
8K (10 ¹ / ₂ × 15.35)	☐	267 × 390	○	★	★	X
16K (7.68 × 10 ¹ / ₂)	☐	195 × 267	○	★	★	X
	☐	267 × 195	○	★	★	X

- ○
Means that the size is supported but the paper size should be set with the control panel. There is no dial on the tray.
See p.40 “Loading Paper in the Bypass Tray”
See p.47 “Loading envelopes into the Envelope Feeder Unit”
- ☆
Means that the size is supported and indicated on the tray dial. Be sure to set the paper size dial to match the actual paper size loaded in the tray.
- ★
Means that the size is supported but not indicated on the tray dial. You should set the tray dial to “✱”, and select the paper size with the control panel.
- ○*
Means that the supported size is approximately 90 - 305 mm in width, and approximately 148 - 432 mm in length. The supported size may differ depending on the printer language you use. Use the printer driver to set custom sizes. Set custom sizes with the control panel.
- ★**
Means that the supported size is approximately 182-297 mm in width, and approximately 148-432 mm in length. The supported size may differ depending on the printer language you use. Use the printer driver to set custom sizes. Set custom sizes with the control panel.
- X
Means that the size is not supported.

◆ Input Paper Sizes (Inch version)

	Feed direction	Size (inch)	Bypass Tray	Paper Tray (Tray1)	Paper Feed Unit (Tray 2/3)	Envelope Feeder Unit
11 × 17	☐	11 × 17	○	☆	☆	X

	Feed direction	Size (inch)	Bypass Tray	Paper Tray (Tray1)	Paper Feed Unit (Tray 2/3)	Envelope Feeder Unit
Legal (LG)	☐	8 ¹ / ₂ × 14	○	☆	☆	X
Letter (LT)	☐	8 ¹ / ₂ × 11	○	☆	☆	X
	☐	11 × 8 ¹ / ₂	○	☆	☆	X
5 ¹ / ₂ × 8 ¹ / ₂	☐	5 ¹ / ₂ × 8 ¹ / ₂	○	X	X	X
Executive (Exec.)	☐	7 ¹ / ₄ × 10 ¹ / ₂	○	X	★	X
	☐	10 ¹ / ₂ × 7 ¹ / ₄	○	★	★	X
A3	☐	11.26 × 16.54	○	★	☆	X
B4 JIS	☐	10.12 × 14.33	○	★	★	X
A4	☐	8.26 × 5.83	○	★	☆	X
	☐	5.83 × 8.26	○	☆	☆	X
B5 JIS	☐	7.17 × 10.12	○	★	★	X
	☐	10.12 × 7.17	○	★	★	X
A5	☐	5.83 × 8.26	○	X	X	X
	☐	8.26 × 5.83	○	★	★	X
A6	☐	4.13 × 5.63	○	X	X	X
Folio	☐	8 ¹ / ₄ × 13	○	★	★	X
Foolscap F4	☐	8 ¹ / ₂ × 13	○	☆	★	X
F/GL	☐	8 × 13	○	★	★	X
Com#10 Env	☐	4 ¹ / ₈ × 9 ¹ / ₂	○	X	X	○
C5 Env	☐	6.38 × 9.02	○	X	X	○
C6 Env	☐	4.49 × 6.38	○	X	X	○
DL Env	☐	4.33 × 8.66	○	X	X	○
Monarch Env	☐	3 ⁷ / ₈ × 7 ¹ / ₂	○	X	X	○
Custom Size	—	—	○*	X	★**	X
8K	☐	10 ¹ / ₂ × 15.35	○	★	★	X
16K	☐	7.68 × 10 ¹ / ₂	○	★	★	X
	☐	10 ¹ / ₂ × 7.68	○	★	★	X

- ○
Means that the size is supported but the paper size should be set with the control panel. There is no dial on the tray.
See p.40 "Loading Paper in the Bypass Tray"
See p.47 "Loading envelopes into the Envelope Feeder Unit"
- ☆
Means that the size is supported and indicated on the tray dial. Be sure to set the paper size dial to match the actual paper size loaded in the tray.
- ★
Means that the size is supported but not indicated on the tray dial. You should set the tray dial to "✱", and select the paper size with the control panel.
- ○*
Means that the supported size is approximately 3.55 - 12.00 inches in width, and approximately 5.83 - 17.00 inches in length. The supported size may differ depending on the printer language you use. Use the printer driver to set custom sizes. Set custom sizes with the control panel.
- ★**
Means that the supported size is approximately 7.16 - 11.7 inches in width, and approximately 5.8 - 17 inches in length. The supported size may differ depending on the printer language you use. Use the printer driver to set custom sizes. Set custom sizes with the control panel.
- X
means that the size is not supported.



























❖ Paper weight and number of sheets to be set

	Supported paper weight	Maximum number of sheets (plain paper) *1
Paper Tray	60 - 105 g/m ² (16 - 28 lb. bond)	250 (80 g/m ² , 20 lb. bond)
Paper Feed Unit Type 2600 (option)	60 - 105 g/m ² (16 - 28 lb. bond)	500 (80 g/m ² , 20 lb. bond)
Bypass Tray	52 - 162 g/m ² (14 - 43 lb. bond)	100 (80 g/m ² , 20 lb. bond) For other kind of papers, see p.33 "Types of Paper and Other Media".
Envelope Feeder Type 2600 *2	p.33 "Types of Paper and Other Media".	

*1 Confirm that the top of the stack is not higher than the limit mark indicated on the side fence of the tray.

























*2 The Envelope Feeder Unit requires the installation of the optional Paper Feed Unit.



◆ Output Paper Sizes (Metric version)

	Feed direction	Size (mm)	Output Tray (Standard Tray)	1-bin Shift Sort Tray	Mailbox	Duplex Unit
A3		297 × 420	○	○	○	○
B4 JIS		257 × 364	○	○	○	○
A4		210 × 297	○	○	○	○
		297 × 210	○	○	○	○
B5 JIS		182 × 257	○	○	○	○
		257 × 182	○	○	○	○
A5		148 × 210	○	X	X	X
		210 × 148	○	○	○	○
A6		105 × 148	○	X	X	X
11 × 17		279 × 432	○	○	○	○
Legal (LG, 8 ¹ / ₂ × 14)		216 × 356	○	○	○	○
Letter (LT, 8 ¹ / ₂ × 11)		216 × 279	○	○	○	○
		279 × 216	○	○	○	○
5 ¹ / ₂ × 8 ¹ / ₂		140 × 216	○	X	X	X
Executive (Exec., 7 ¹ / ₄ × 10 ¹ / ₂)		184 × 276	○	○	○	X
		276 × 184	○	○	○	○
Folio (8 ¹ / ₄ × 13)		210 × 330	○	○	○	○
Foolscap (F4, 8 ¹ / ₂ × 13)		216 × 330	○	○	○	○
F/GL (8 × 13)		203 × 330	○	○	○	○
Com#10 Env (4 ¹ / ₈ × 9 ¹ / ₂)		104.8 × 241.3	○	X	X	X
CA Env (6.38 × 9.02)		162 × 229	○	X	X	X
C6 Env (4.49 × 6.38)		114 × 162	○	X	X	X
DL Env (4.33 × 8.66)		110 × 220	○	X	X	X
Monarch Env (3 ⁷ / ₈ × 7 ¹ / ₂)		98.4 × 190.5	○	X	X	X
Custom Size	—	—	○	X	X	X
8K (10 ¹ / ₂ × 15.35)		267 × 390	○	○	○	○
16K (7.68 × 10 ¹ / ₂)		195 × 267	○	○	○	○
		267 × 195	○	○	○	○

- Means that the size is supported.
- X Means that the size is not supported.

◆ Output Paper Sizes (Inch version)

	Feed direction	Size (inch)	Output Tray (Standard Tray)	1-bin Shift Sort Tray	Mailbox	Duplex Unit
11 × 17		11 × 17	<input type="radio"/>	<input type="radio"/>	<input type="radio"/>	<input type="radio"/>
Legal (LG)		8 ¹ / ₂ × 14	<input type="radio"/>	<input type="radio"/>	<input type="radio"/>	<input type="radio"/>
Letter (LT)		8 ¹ / ₂ × 11	<input type="radio"/>	<input type="radio"/>	<input type="radio"/>	<input type="radio"/>
		11 × 8 ¹ / ₂	<input type="radio"/>	<input type="radio"/>	<input type="radio"/>	<input type="radio"/>
5 ¹ / ₂ × 8 ¹ / ₂		5 ¹ / ₂ × 8 ¹ / ₂	<input type="radio"/>	<input checked="" type="radio"/>	<input checked="" type="radio"/>	<input checked="" type="radio"/>
Executive (Exec.)		7 ¹ / ₄ × 10 ¹ / ₂	<input type="radio"/>	<input type="radio"/>	<input type="radio"/>	<input checked="" type="radio"/>
		10 ¹ / ₂ × 7 ¹ / ₄	<input type="radio"/>	<input type="radio"/>	<input type="radio"/>	<input type="radio"/>
A3		11.26 × 16.54	<input type="radio"/>	<input type="radio"/>	<input type="radio"/>	<input type="radio"/>
B4 JIS		10.12 × 14.33	<input type="radio"/>	<input type="radio"/>	<input type="radio"/>	<input type="radio"/>
A4		8.26 × 5.83	<input type="radio"/>	<input type="radio"/>	<input type="radio"/>	<input type="radio"/>
		5.83 × 8.26	<input type="radio"/>	<input type="radio"/>	<input type="radio"/>	<input type="radio"/>
B5 JIS		7.17 × 10.12	<input type="radio"/>	<input type="radio"/>	<input type="radio"/>	<input type="radio"/>
		10.12" × 7.17	<input type="radio"/>	<input type="radio"/>	<input type="radio"/>	<input type="radio"/>
A5		5.83 × 8.26	<input type="radio"/>	<input checked="" type="radio"/>	<input checked="" type="radio"/>	<input checked="" type="radio"/>
		8.26 × 5.83	<input type="radio"/>	<input type="radio"/>	<input type="radio"/>	<input type="radio"/>
A6		4.13 × 5.63	<input type="radio"/>	<input checked="" type="radio"/>	<input checked="" type="radio"/>	<input checked="" type="radio"/>
Folio		8 ¹ / ₄ × 13	<input type="radio"/>	<input type="radio"/>	<input type="radio"/>	<input type="radio"/>
Foolscap F4		8 ¹ / ₂ × 13	<input type="radio"/>	<input type="radio"/>	<input type="radio"/>	<input type="radio"/>
F/GL		8 × 13	<input type="radio"/>	<input type="radio"/>	<input type="radio"/>	<input type="radio"/>
Com#10 Env		4 ¹ / ₈ × 9 ¹ / ₂	<input type="radio"/>	<input checked="" type="radio"/>	<input checked="" type="radio"/>	<input checked="" type="radio"/>
C6 Env		4.49 × 6.38	<input type="radio"/>	<input checked="" type="radio"/>	<input checked="" type="radio"/>	<input checked="" type="radio"/>
C5 Env		6.38 × 9.02	<input type="radio"/>	<input checked="" type="radio"/>	<input checked="" type="radio"/>	<input checked="" type="radio"/>
DL Env		4.33 × 8.66	<input type="radio"/>	<input checked="" type="radio"/>	<input checked="" type="radio"/>	<input checked="" type="radio"/>
Monarch Env		3 ⁷ / ₈ × 7 ¹ / ₂	<input type="radio"/>	<input checked="" type="radio"/>	<input checked="" type="radio"/>	<input checked="" type="radio"/>
Custom Size	—	—	<input type="radio"/>	<input checked="" type="radio"/>	<input checked="" type="radio"/>	<input checked="" type="radio"/>
8K		10 ¹ / ₂ × 15.35	<input type="radio"/>	<input type="radio"/>	<input type="radio"/>	<input type="radio"/>

	Feed direction	Size (inch)	Output Tray (Standard Tray)	1-bin Shift Sort Tray	Mailbox	Duplex Unit
16K		$7.68 \times 10^{1/2}$	<input type="radio"/>	<input type="radio"/>	<input type="radio"/>	<input type="radio"/>
		$10^{1/2} \times 7.68$	<input type="radio"/>	<input type="radio"/>	<input type="radio"/>	<input type="radio"/>

- Means that the size is supported and that the paper size should be set with the control panel. There is no dial on the tray.
- Means that the size is not supported.

Paper Recommendations

Note the following suggestions when handling or selecting paper used with this printer.

Loading Paper

- Confirm the paper types of the printer. For more information, see p.33 “Types of Paper and Other Media”. Print quality cannot be guaranteed if other paper types are used.
- Do not use paper that is already printed on.
- If you load paper into the paper tray, be sure not to stack over the limit mark.
- If you load paper onto the Bypass Tray, be sure that paper fits under the side guide.
- If you load paper into the paper tray, confirm that the print side is facing *down*.
- If you load paper onto the Bypass Tray, confirm that the print side is facing *up*.

Storing Paper

Paper should always be stored properly. Improperly stored paper might result in poor print quality, paper misfeeds or printer damage.

Recommendations are as follows:

- Avoid storing paper in humid areas.
- Avoid exposing paper to direct sunlight.
- Store on a flat surface.
- Keep open reams of paper in the package in which the paper came.

Types of Paper and Other Media

❖ Plain paper

- If you print on paper heavier than 105 g/m² (28 lb. bond), use the Bypass Tray. The Bypass Tray can hold paper up to 162 g/m² (43 lb. bond) in weight.
- If you load paper heavier than 155 g/m² (41 lb. bond) onto the Bypass Tray, set the printer to Thick Paper mode using the control panel.
- If paper is curled or bent, correct it before loading.

❖ **OHP transparencies**

- Load only one OHP transparency at the same time onto the Bypass Tray.
- When loading an OHP transparency onto the Bypass Tray, set the printer to Transparency mode with the control panel.
- Be careful not to touch the print side of the OHP transparencies, otherwise the print side gets dirty or damaged, and results in poor print quality.
- When printing on an OHP transparency that has a print side, load it facing down onto the Bypass Tray.

❖ **Adhesive labels**

- Load only one adhesive label at the same time onto the Bypass Tray.
- Use adhesive labels in which the whole side can be printed on.
- Do not use adhesive labels having exposed glue.
- If the print side is coated, print quality might be reduced, as the toner might not fuse well.

❖ **Envelopes**

- When printing on envelopes, use the Bypass Tray or the Envelope Feeder Unit.
- Even when the optional Envelope Feeder Unit is not installed, you can select the sizes for the Envelopes for Tray 2 using the control panel. However, you cannot load the envelopes until optional Envelop Feeder Unit is installed.

To use the Envelope Feeder Unit, installation of the optional Paper Feed Unit is required. See “Envelope Feeder Type 2600” in the Setup Guide.

- Specifications of envelopes are as follows:

	Metric version	Inch version
Weight	72 – 90 g/m ²	19 – 24 lb. bond
Recommended weight and size	72 g/m ² , 114 × 162 mm (C6 Env)	24 lb. bond, 3 ⁷ / ₈ × 7 ¹ / ₂ inches (Monarch)

- You can load up to 10 envelopes (72 – 90 g/m², 19 – 24 lb. bond) onto the Bypass Tray at the same time, without forcibly pressing them. Confirm that the envelopes are not damp, and that the top of the stack is not higher than the limit mark on the side guide. See p.45 “Loading envelopes onto the Bypass Tray”.
- You can load up to 60 envelopes (72 – 90 g/m², 19 – 24 lb. bond) into optional Envelope Feeder Unit at the same time, without forcibly pressing them. Confirm that the envelopes are not damp, and that the top of the stack is not higher than the limit mark on the side guide. See p.47 “Loading envelopes into the Envelope Feeder Unit”.
- Confirm that the print side is facing up when loading onto the Bypass Tray, and facing down when loading into the optional Envelope Feeder Unit.

- Load the envelopes with the flaps aligned to the left side fence. The flaps should be securely folded up.
- Confirm that there is no air in the envelopes before loading.
- To get better print quality, it is recommended that you set the right, left, top, and bottom print margin, to at least 15 mm (0.6 inches) each.
- Do not print on both sides of envelopes.
- Load only one size and type of envelopes at the same time.
- Before loading envelopes, flatten the leading edges (the side being fed into the printer) of them by running a pencil or ruler across them.
- Before loading envelopes, confirm that they are rectangular in shape.
- Do not use the non-supported envelopes listed on p.29 "Paper weight and number of sheets to be set".

Paper not supported by this printer

Avoid using the following types of paper that are not supported by this printer:

- Paper whose weight is heavier or lighter than the limitation. See p.25 "Paper Types and Sizes".
- Bent, folded or creased paper
- Curled or twisted paper
- Torn paper
- Wrinkled paper
- Damp paper
- Paper stuck together
- Paper that is dry enough to emit static electricity
- Paper that has already been printed on, with the exception of preprinted letterhead

Note

- Ink on paper from an earlier print job, another copier, an inkjet printer or other device could damage the fusing unit of this printer due to a difference in fusing temperatures.
- Coated paper
- Special paper like thermal paper, aluminum foil, carbon paper and conductive paper
- Heavily textured paper
- Glued paper
- Label paper on which glue or base paper is exposed
- Paper with clips or stapled
- Paper with tape or ribbons attached
- Envelopes in the following conditions:

- damp
- excessively curled or twisted
- stuck together
- damaged in any way
- with stamps attached
- with windows, holes, perforations, cutouts or embossing
- with metal clasps, string ties or metal folding bars
- designed to be interlocked
- with nicked edges or bent corners
- with rough, wrinkled or laid finishes
- with any exposed adhesive, when the flap is in the sealed or closed position

Printable Area

The following shows the printable area for this printer. Be sure to set the print margins correctly by the application.

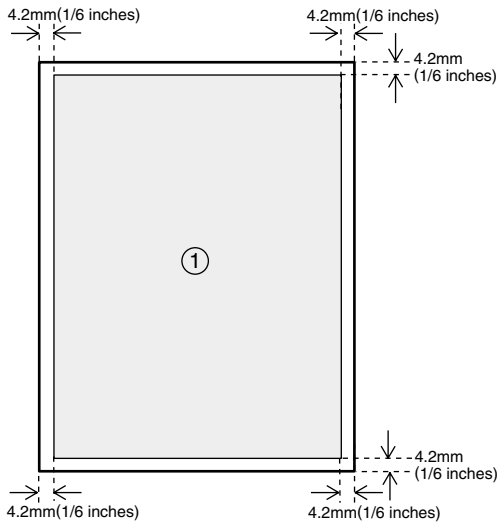

① : printable area

Important

- The maximum printable length is 432 mm (17 inches) in the paper feed direction.

Note

- The printable area may vary depending on the paper size, printer language and printer driver settings.

Loading Paper and Other Media

Loading Paper in the Paper Tray

Load paper in the optional Paper Feed Unit by following the procedures below.

Reference

With the paper tray, you can load up to 250 pages and with the optional Paper Feed Unit, you can load up to 500 pages at the same time. For more information about the type, size and feed direction of paper that can be loaded in the tray, see p.25 “Paper Types and Sizes”.

When you change the paper size see p.38 “Changing the paper size”.

- 1** Lift the paper tray slightly then pull it out until it stops.

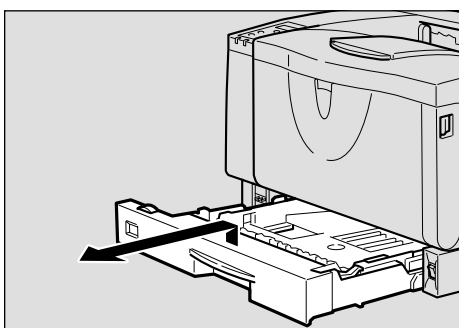

ZCEY430J

- 2** While lifting the front side of the tray, pull it out of the printer.

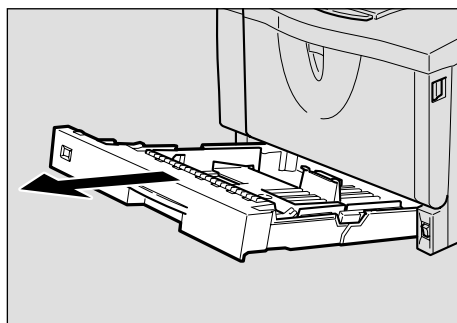

ZCEY140J

- 3** Load paper into the tray with the print side down.

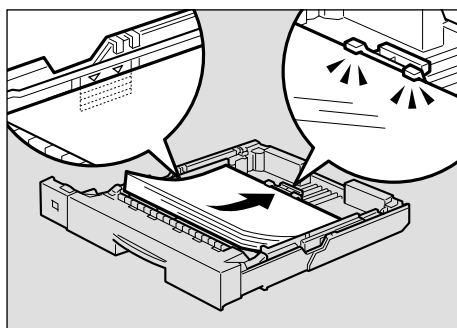

ZCEY130J

Important

- Confirm that the top of the stack is not higher than the limit mark inside the tray.
- Confirm that paper fits under the rear guide.

- 4** Carefully slide the paper tray into the printer until it stops.

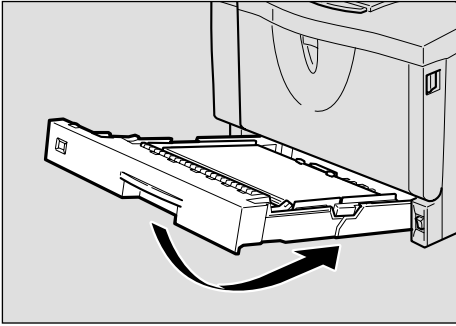

Important

- Do not slide the paper tray in with force. If you do, the front and side guides might move.

Changing the paper size

Important

- Confirm that the setting of the paper size dial matches the paper size and feed direction of the paper in the tray, otherwise the printer might be damaged, or printing problems might occur.

- 1** Lift the paper tray slightly then pull it out until it stops. Adjust the paper size dial to match the size and feed direction of paper in the paper tray.

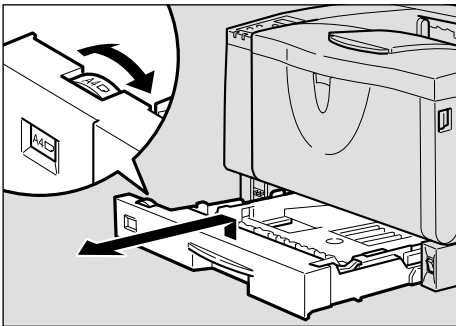

Important

- If you want to use the paper size and feed direction that are not indicated on the paper size dial, set the dial to “*”. In this case, you should set the paper size using the control panel. See p.106 “Paper Input Menu”.

- 2** While lifting the front side of the tray, pull it out of the printer.

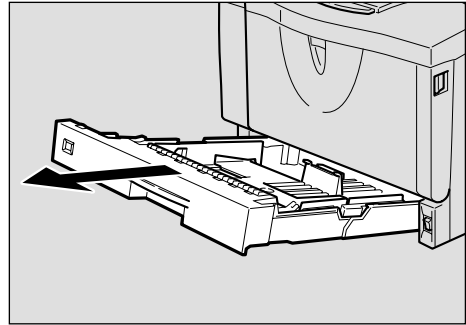

- 3** If you load paper larger than A4 or 8 1/2 x 11, you should extend the tray as follows:

Note

- You cannot load paper smaller than A4 or 8 1/2 x 11, if the tray is extended. In this case, return the tray to its standard length.

- 1** Slide the catches inwards to unlock the tray.

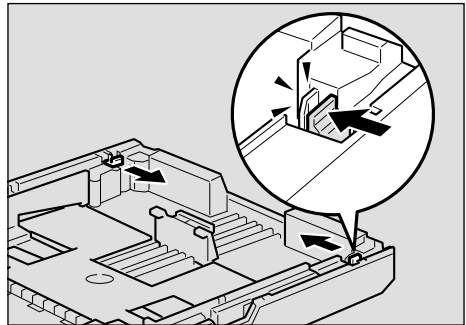

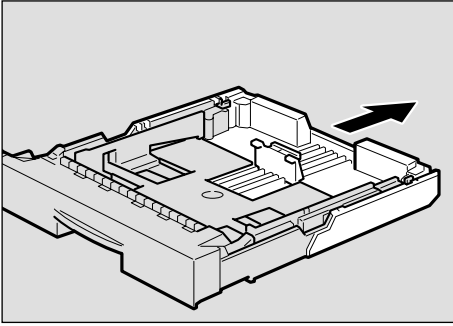
2 Slide the tray until it stops.

ZCEY170J

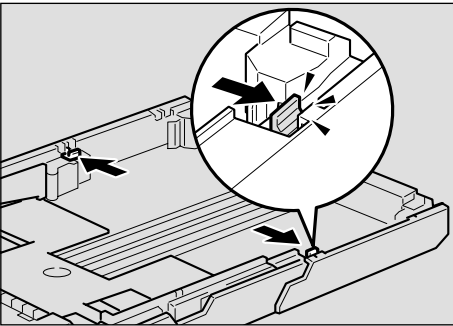
3 Return the catches to their original positions.

ZCEY180J

Important

- Confirm that the catches return to their original positions securely. If they are not locked securely, paper mis-feeds might occur.

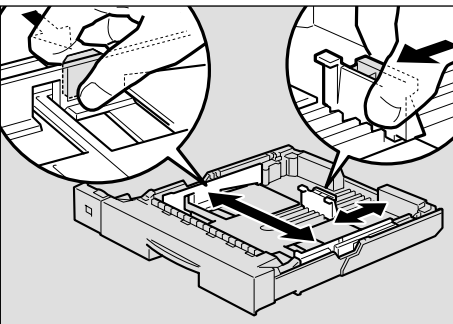
4 Adjust the rear and side guides to the paper size you want to load.

ZGDY120J

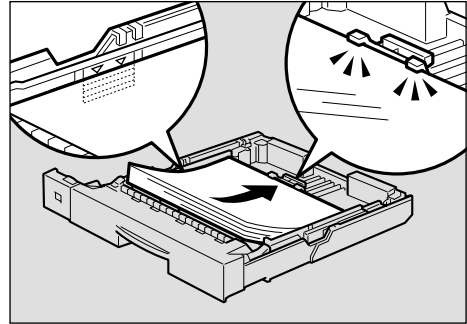
5 Load paper into the tray with the print side down.

ZCEY130J

Important

- Confirm that the top of the stack is not higher than the limit mark inside the tray.
- Confirm that paper fits under the rear guide.

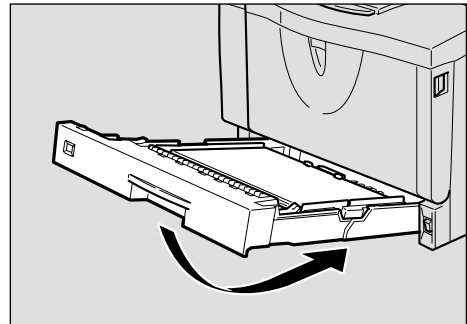
6 Carefully slide the paper tray into the printer until it stops.

ZCEY150J

Important

- Do not slide the paper tray in with force. If you do, the front and side guides might move.

Loading Paper in the Bypass Tray

Reference

With the Bypass Tray, you can load up to 100 pages at the same time. For more information about the type, size and feed direction of paper that can be loaded in the tray, see p.25 "Paper Types and Sizes".

Note

- ❑ If you set custom size paper, you should set the paper size using the printer driver. Also, use the control panel to set the custom size setting.

1 Open the Bypass Tray.

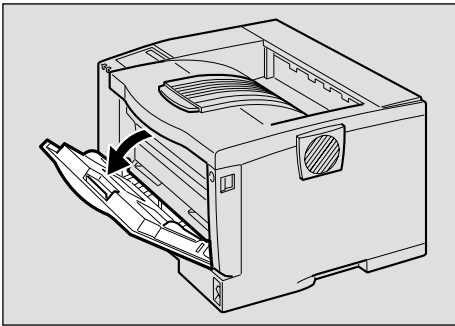

ZGDY190J

2 Slide the side guides outward, and load paper until it stops with the print side up.

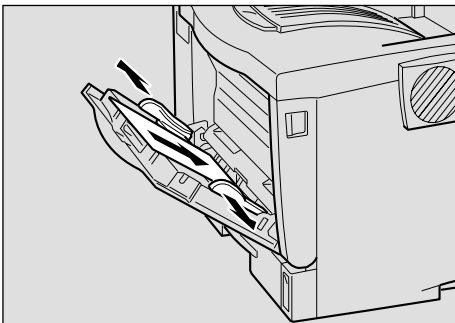

ZGDY200J

Note

- ❑ If you load A4 or larger, or 8¹/₂ × 11 or larger, slide out the Bypass Tray extension (1) and then flip it open (2).

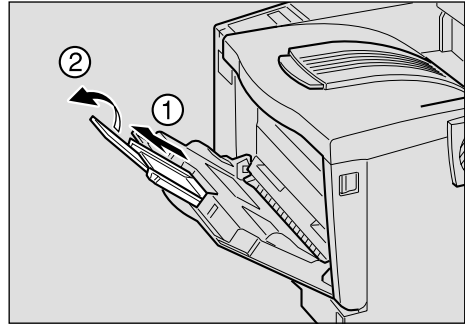

ZGDY210J

3 Adjust the side guides to the paper width.

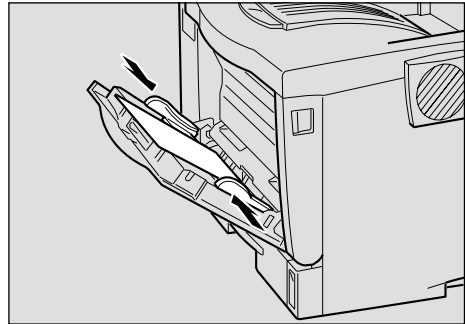

ZGDY220J

Important

- ❑ Confirm that paper fits under the side guides.

- 4** Set the paper size and feed direction using the control panel as follows:

- 1** Press **[Menu]**.

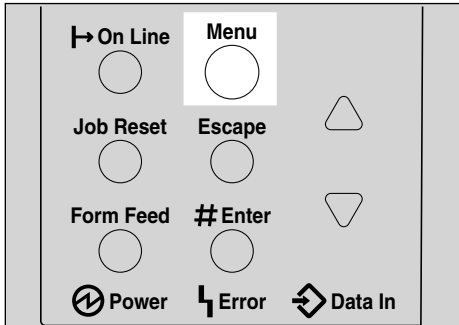

"Menu" appears on the panel display.

- 2** Press **[▼]** or **[▲]** to "Paper Input" menu.

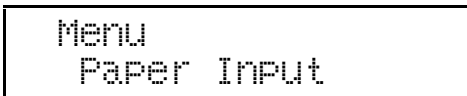

- 3** Press **[Enter #]**.

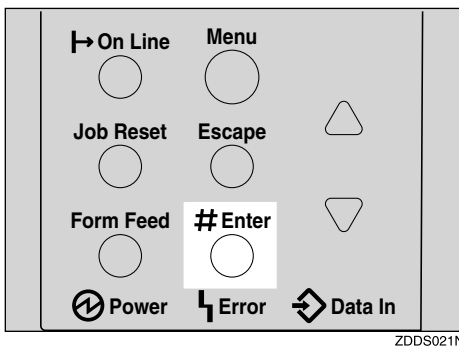

The following message appears on the panel display.

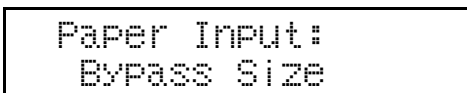

- 4** Press **[Enter #]**.

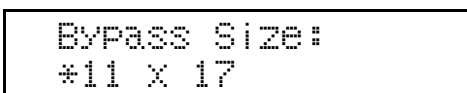

- 5** Press **[▼]** or **[▲]** to select the paper size you want to use.

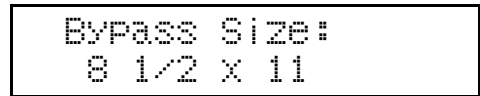

- 6** Press **[Enter #]** to apply the setting. Wait for a while.

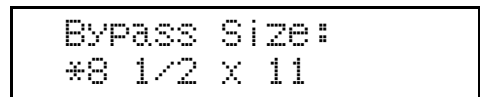

The screen returns to step **3** in a few seconds.

- 7** After the panel display changes, press **[On Line]**.

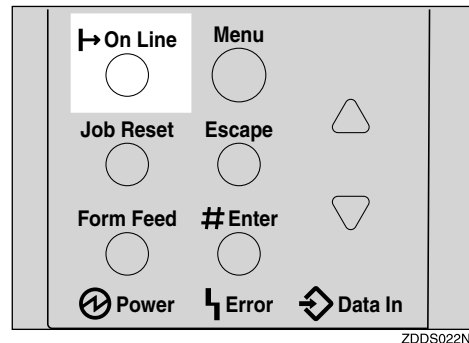

"Ready" appears on the panel display.



- 5** Start printing with the computer.

Loading custom sized paper in the Bypass Tray

Important

- ❑ The settings of custom sized paper that take effect are not the settings made on the control panel but the settings made in the printer driver. There is no need to change the settings on the control panel. However, when using a printer driver other than RPCS, you will need to change the settings on the control panel.
- ❑ Applications that do not allow a custom paper size to be set cannot print on custom sized paper.

Note

- ❑ If you print on A3 or longer sheets, prints may become blurred.

1 Press **[Menu]**.

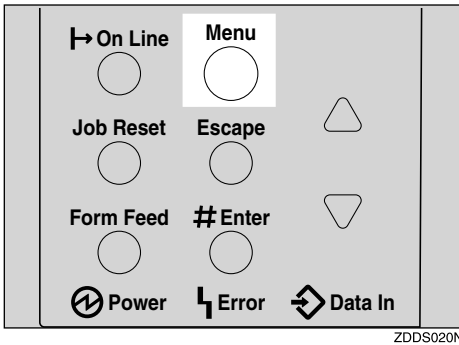

"Menu" appears on the panel display.

2 Press **[▼]** or **[▲]** to display "Paper Input" menu.

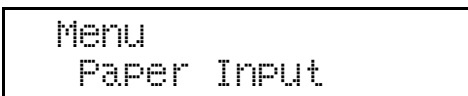

3 Press **[Enter #]**.



The following message appears on the panel display.

4 Press **[▼]** or **[▲]** to display "Custom Size".

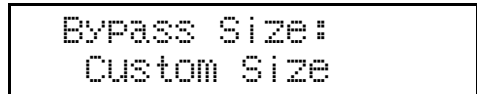

5 Press **[Enter #]**.

The following message appears on the panel display.

6 Press **[▼]** or **[▲]** to display the length in the feed direction, and then press **[Enter #]**.

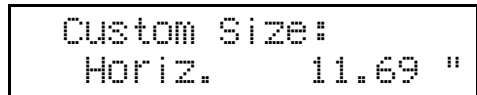

The screen to enter the size along the length appears.

7 Press **[▼]** or **[▲]** to display the size along the length of the feed direction, and then press **[Enter #]**.

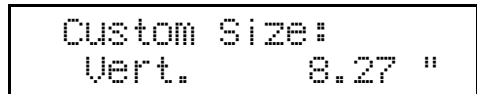

The screen returns to step **4** in a few seconds.

8 Press **[On Line]**.



"Ready" appears on the panel display.

Setting the Bypass Tray Paper Type

To make sure printing is done correctly, you must specify one of the following for the type of sheets loaded in the tray:

- Plain paper, Recycled paper, Special paper, Color paper, Letterhead, Preprinted, Labels, Bond paper, Cardstock, Transparencies, Thick paper

Important

- ❑ When you load thick paper or transparencies in the Bypass Tray, always specify the type of paper. Duplex printing is not possible on paper in a tray for which Thick paper or Transparency has been set.

1 Press [Menu].

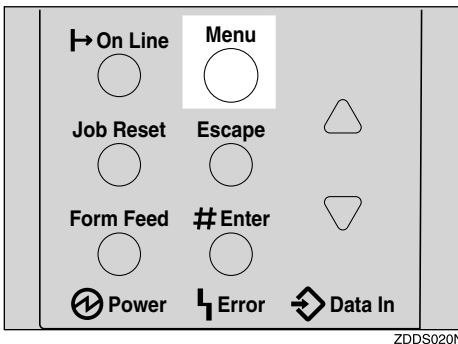

"Menu" appears on the panel display.

2 Press [▼] or [▲] to display "Paper Input" menu.

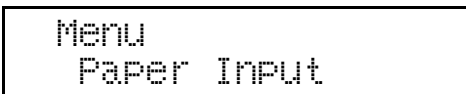

3 Press [Enter #].

The following message appears on the panel display.

4 Press [▼] or [▲] to display "Paper Type".

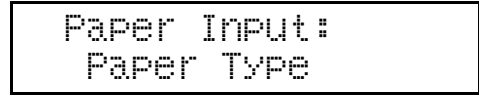

5 Press [Enter #].

The following message appears on the panel display.

6 Press [▼] or [▲] to display "Bypass Tray", and then press [Enter #].

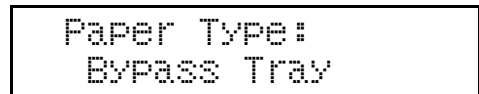

The screen to select the paper type appears.

7 Press [▼] or [▲] to display the type of paper you have loaded, and then press [Enter #].

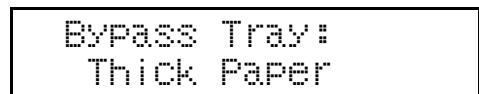

The screen returns to step 6 in a few seconds.

8 Press [On Line].



"Ready" appears on the panel display.

Loading Paper in the Optional Paper Tray

Reference

With the Paper Feed Unit, you can load up to 500 pages at the same time.

For more information about the type, size and feed direction of paper that can be loaded in the tray, see p.25 “Paper Types and Sizes”.

Important

- ❑ If the printer is equipped with the optional tray(s), do not slide out more than one tray at the same time. If you do, the printer might fall down.
- ❑ Confirm that the setting of the paper size dial matches the paper size and feed direction of the paper in the tray. If different, the printer might be damaged, or printing problems might occur.

1 Lift the paper tray slightly then pull it out until it stops. Adjust the paper size dial to match the size and feed direction of paper in the Paper Feed Unit.

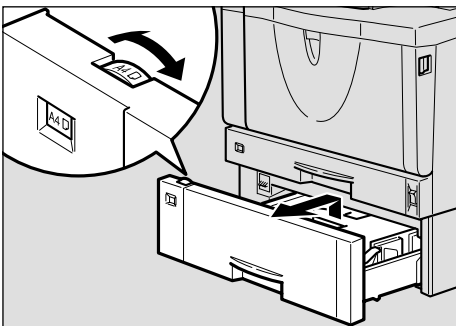

ZOEY230J

Important

- ❑ If you want to use paper sizes or feed directions that are not listed on the paper size dial, adjust the dial to “✖”. In this case, you should set the paper size using the control panel. See p.106 “Paper Input Menu”.

2 While lifting the front side of the tray, pull it out of the printer.

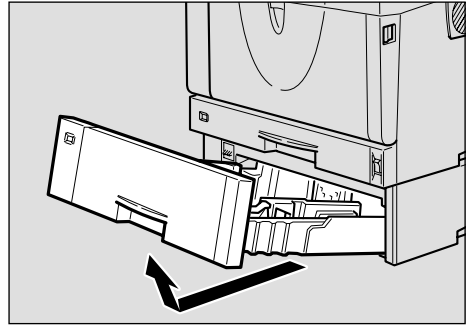

ZDDP330E

3 Adjust the rear and side guides to the paper size you want to load.

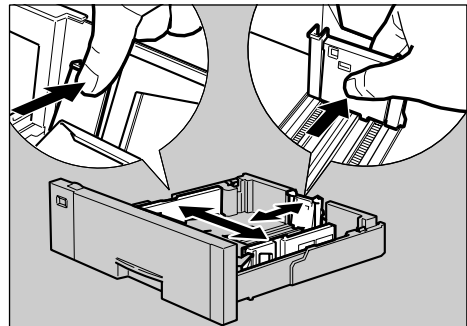

ZGDY250E

- 4** Load paper into the paper tray with the print side down.

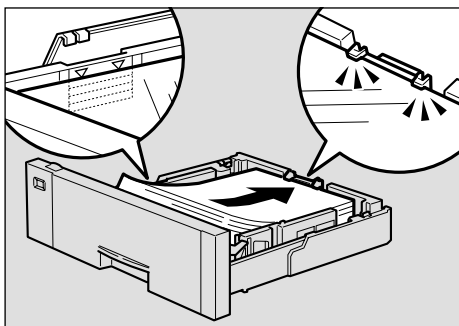

ZCEY260J

Important

- Confirm that the top of the stack is not higher than the limit mark inside the tray.
- Confirm that paper fits under the rear guide.

- 5** While lifting the front of the tray, place the tray into the printer. Then slide it inside until it stops.

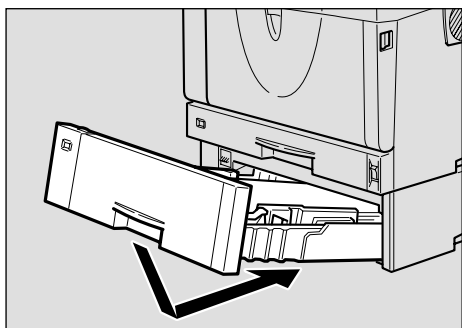

ZDDP340E

Important

- Do not slide the paper tray in with force. If you do, the front and side guides might move.

Loading Envelopes

As there are many kinds of envelopes, be sure to check if those to be used are supported by this printer.

Reference

For more information about envelopes, see p.33 "Types of Paper and Other Media".

Important

- Even when the optional Envelope Feeder Unit is not installed, you can select the sizes for the envelopes for Tray 2 using the control panel. However, you cannot load the envelopes until the optional Envelope Feeder Unit is installed.
- To install the Envelope Feeder Unit, the optional Paper Feed Unit must be installed. See "Envelope Feeder Type 2600" in the Setup Guide.

Loading envelopes onto the Bypass Tray

Reference

With the Bypass Tray, you can load up to 10 envelopes at the same time. For more information about envelopes, see p.33 "Types of Paper and Other Media".

- 1** Open the Bypass Tray.

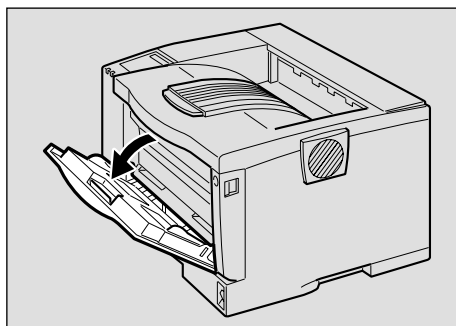

ZGDY190J

2 Load envelopes until they stop, with the print side up and the sides of the flaps on the left as shown below.

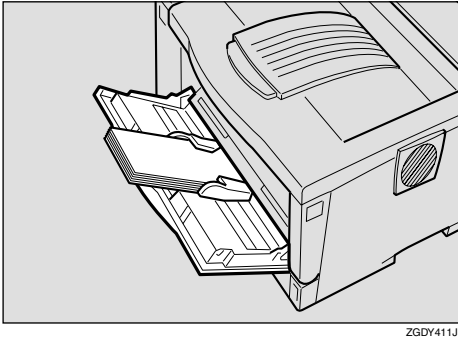

Important

Confirm that the envelope flaps are securely folded down, and that there is no air inside the envelopes.

Note

- Confirm that the top of the stack is not higher than the limit mark on the side guides.
- Do not push the stack of envelopes with too much force.

3 Slide the side guides against the edge of the envelope stack.

Note

Confirm that the edges of envelopes fit under the side guides.

4 Set the envelope size and feed direction using the control panel as follows:

1 Press **[Menu]**.

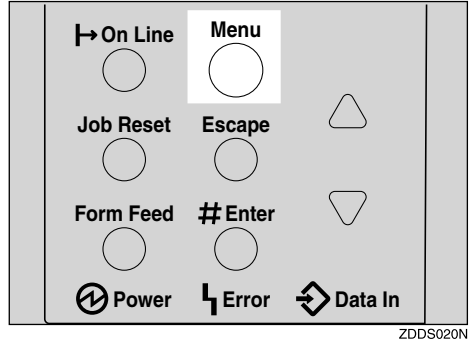

"Menu" appears on the panel display.

2 Press **[▲]** or **[▼]** to display "Paper Input" menu.



3 Press **[Enter #]**.

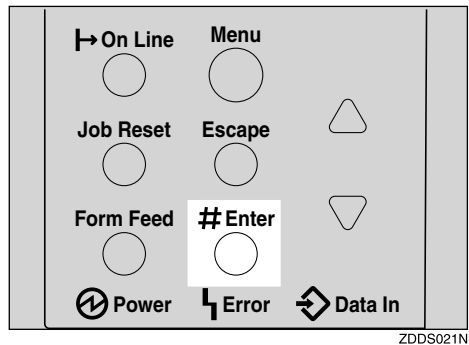

The following message appears.

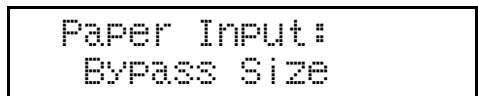

4 Press **[Enter #]**.

3

- 5 Press **[▲]** or **[▼]** to select the envelope type you want to use.

Reference

For information about types of envelopes you can select, see p.25 "Paper and Other Media Supported by This Printer".

- 6 Press **[Enter #]** to apply the settings. Wait for a while.
- 7 After the panel display changes, press **[On Line]**.

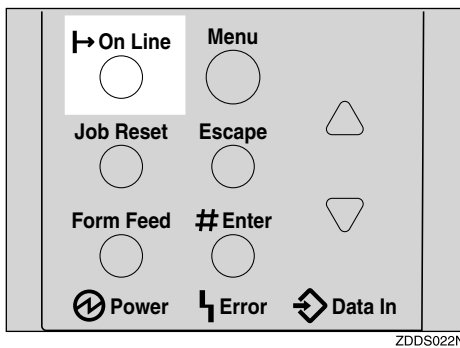

"Ready" appears on the panel display.



- 5 Start printing with the computer.

Loading envelopes into the Envelope Feeder Unit

Important

- With the optional Envelope Feeder Unit, you can load up to 60 envelopes at the same time. For more information about envelopes, see p.33 "Types of Paper and Other Media".

- 1 Slide the optional Paper Feed Unit (Tray 2) out until it stops. Next, lift it slightly, then slide it out.

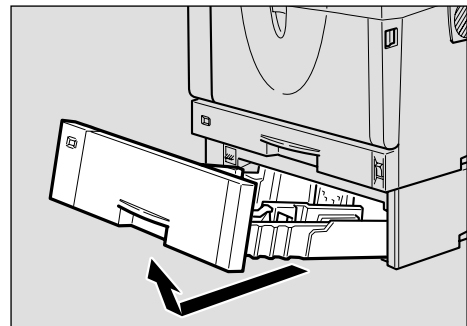

Note

- Keep the paper tray with paper in a cool and dry place.

- 2 Prepare the Envelope Feeder Unit.

- 3 While pinching the side guides, slide them outward until they stop. While pinching the rear guide, slide it toward the back.

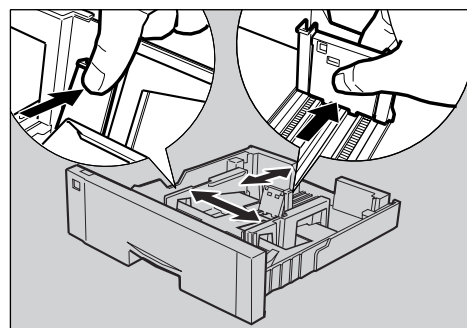

4 Push the bottom plate down until it locks into place.

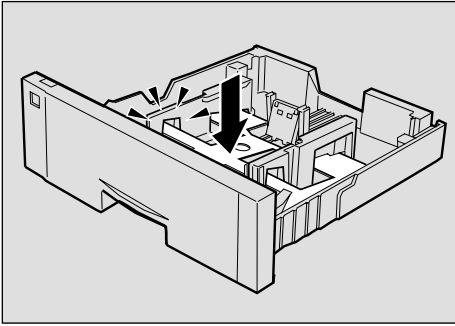

ZDDP380E

6 While pinching the side guides, slide them along the edge of the envelope stack.

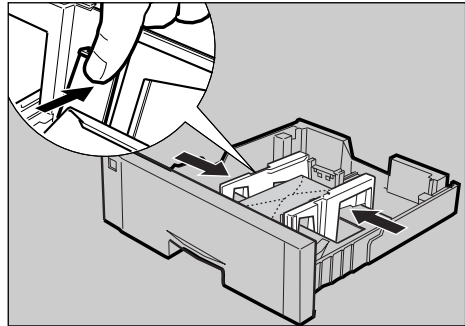

ZGDY370E

5 Load envelopes into the Envelope Feeder Unit, with the print side down and the flap on the left as shown in the illustration.

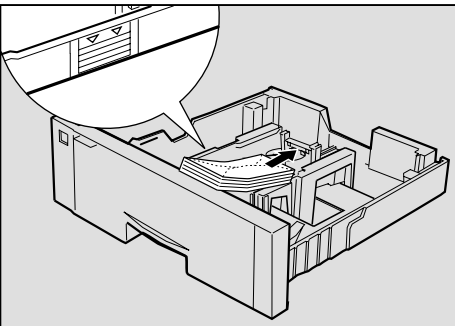

ZDDP380E

7 While pinching the rear guide, slide it along the edge of the envelope stack.

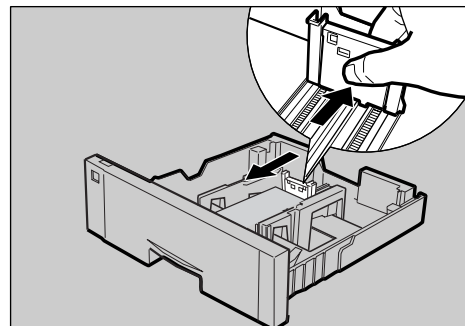

ZGDY390E

Important

- Confirm that the envelope flaps are securely folded down, and that there is no air inside the envelopes.

Note

- Confirm that the top of the stack is not higher than the limit mark on the side guides.
- Confirm that the envelopes fit under the side guides.
- Do not push the stack of envelopes with too much force.

8 While lifting the front of the tray, place it into the printer. Then slide it until it stops.

Important

- Do not slide the paper tray in with force. If you do, the front and side guides might move.

- 9** Set the envelope size and feed direction using the control panel as follows:

- 1** Press **[Menu]**.

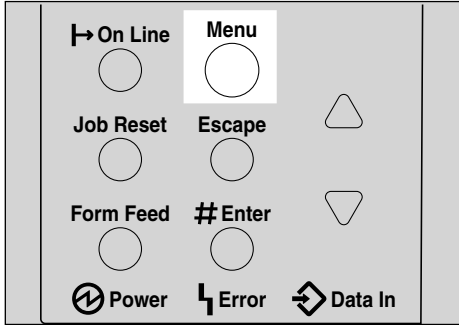

ZDDS020N

“Menu” appears on the panel display.

- 2** Press **[▲]** or **[▼]** to display “Paper Input” menu.

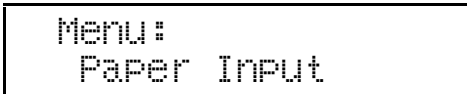

- 3** Press **[Enter #]**.

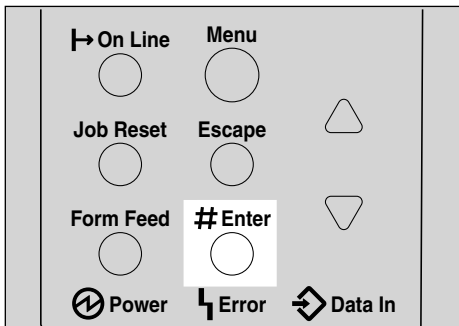

ZDDS021N

The following message appears on the panel display.

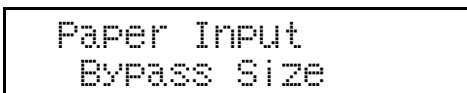

- 4** Press **[▲]** or **[▼]** to display “Tray Paper Size”.



- 5** Press **[Enter #]**.

The following message appears on the panel display.



- 6** Press **[▲]** or **[▼]** to display “Tray 2”.

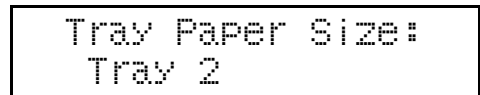

- 7** Press **[Enter #]**.

- 8** Press **[▲]** or **[▼]** to select the envelope type you want to use.

Reference

For more information about types of envelopes you can select, see p.25 “Paper and Other Media Supported by This Printer”.

- 9** Press **[Enter #]**. Wait for a while.

- 10 After the panel display changes, press **[On Line]**.

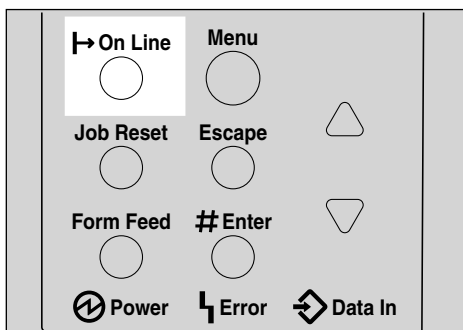

"Ready" message appears on the control panel.



- 10 Start printing with the computer.

4. Sample Print/Locked Print

Sample Print

Use this function to print only the first set of a multiple-set print jobs. The remaining sets are saved on the optional Hard Disk Drive in the printer. The saved job can be printed or canceled from the printer's control panel.

Important

- Turning the printer off deletes any documents or error logs stored on the optional hard disk drive.

Limitation

- To use this function, the optional Hard Disk Drive must be installed on the printer.

Note

- If the application has a collate option, confirm that it is not selected before sending a print job. By default, sample print jobs are automatically collated by the printer driver. If the collate option is selected from the application print dialog box, more pages than intended may be printed.
- You can identify the file you want to print by the User ID and the time when the job was stored.
- The actual number of pages the printer can save depends on the contents of the print images. For example, the printer can save up to 30 jobs or 1,000 pages. It depends on the data volume.

- If the first set of the sample print file is not as you expected and you do not want to print the remaining sets, delete the sample print file using the control panel. If you print the remaining sets of the sample print file, the job in the printer is deleted automatically.

Printing a Sample Print File

The following procedure describes how to print a sample print file with the PCL printer driver. For information about how to print a sample print file with the PostScript printer driver, see the PostScript 3 Operating Instructions Supplement included on the CD-ROM. For more information about RPCS printer driver, see Help.

- 1** From an application, select the menu command to print.

The print dialog box appears.

- 2** Open the Printer Properties.

- 3** From the [Job Type:] box on the [Setup] tab, select [Sample Print].

- 4** Click the [Details...] button.

- 5** In the [User ID:] box, type a User ID of up to eight alphanumeric characters.

Note

- This is used to identify the user associated with a job.
- The User ID can consist of up to eight alphanumeric (a-z, A-Z, 0-9) characters.

- 6** Click [OK].
- 7** After making all desired settings, click [OK].
- 8** Start printing from the application's print dialog box.

The sample print job is sent to the printer and the first set is printed.

- 9** Check the print job to confirm whether the settings are acceptable.

If the settings are fine, go to step **10** to print the rest of the print job.

If not, you can delete the saved job. See p.53 "Deleting a Sample Print File"

- 10** On the printer's control panel, press [Menu].

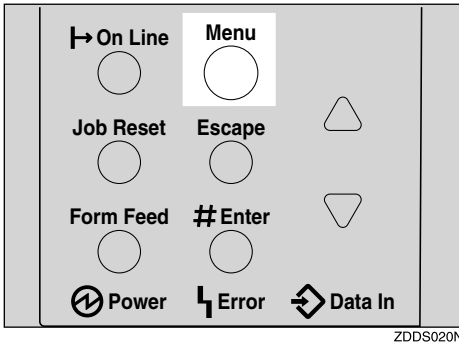

"Menu" appears on the panel display.

- 11** Press [▼] or [▲] to display the "Sample Print" menu.

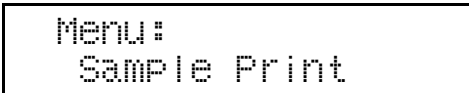

- 12** Press [Enter #].

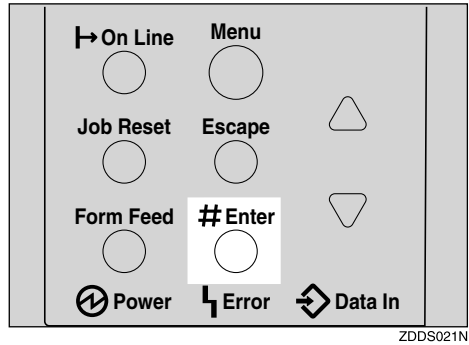

The following message appears on the panel display.



- 13** Press [▼] or [▲] to display the file you want to print, and then press [Enter #].



Note

- If you want to cancel the sample print file, press [Escape].

- 14** Press [Enter #].

The following message appears on the panel display.

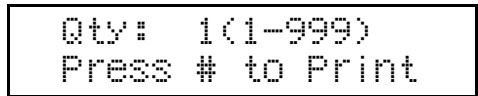

- 15** Press [▲] or [▼] to enter the number of sets.

Note

- You can enter up to 999 sets.

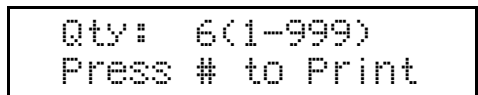

16 Press **[Enter #]** to print the file.

The following message appears on the panel display.

```
Processing...
```

Note

- If you are not satisfied with the first printout of the sample print file and do not want to print the remainder, the job in the printer is deleted automatically.

Deleting a Sample Print File

If you are not satisfied with the printout, delete the sample print file. Then revise it and print again until the settings are fine.

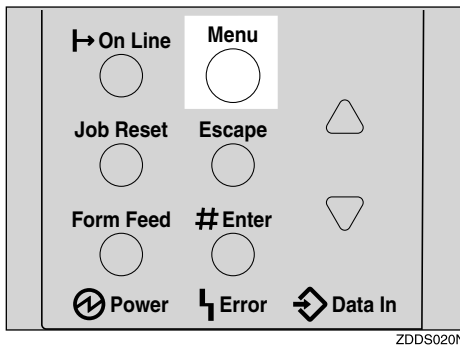
1 Press **[Menu]**.

"Menu" appears on the panel display.

2 Press **[▼]** or **[▲]** to display the "Sample Print" menu .

```
Menu:
Sample Print
```

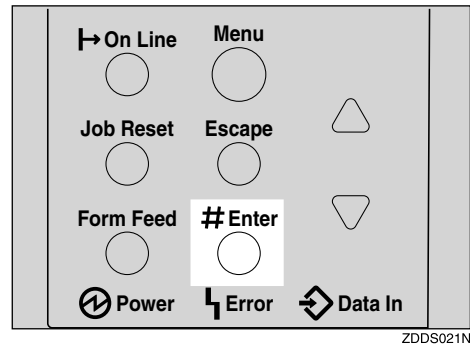
3 Press **[Enter #]**.

The following message appears on the panel display.

```
Sample Print:
08:56 ABCD1234
```

4 Press **[▼]** or **[▲]** to display the file you want to delete, and then press **[Enter #]**.

The following message appears on the panel display.

```
Select Action:
Print File
```

Note

- If you want to cancel the deletion of a sample print file, press **[Escape]**.

5 Press **[▼]** or **[▲]** to display "Delete File", and then press **[Enter #]**.

```
08:56 ABCD1234
Press# to Delete
```

6 Press **[Enter #]** to delete the file.

The following message appears on the panel display.

```
Deleted
```

7 Press **[On Line]**.

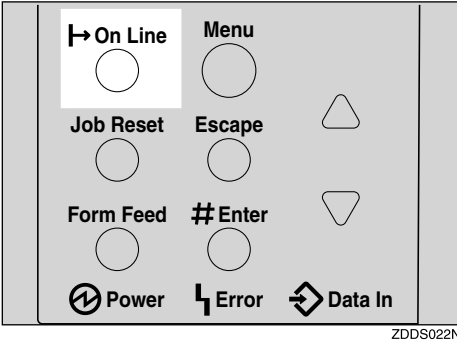

"Ready" appears on the panel display.



3 Press **[Enter #]**.

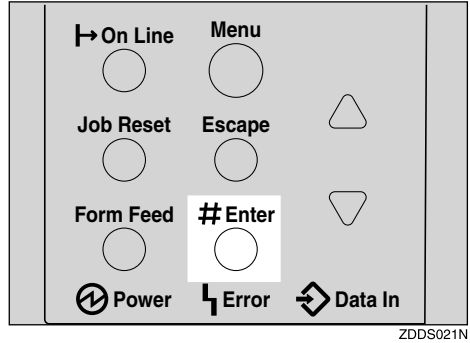

The following message appears on the panel display.



4

Checking the Error Log

! **Limitation**

- You can view only the latest 20 error logs of all.

1 Press **[Menu]**.

"Menu" appears on the panel display.

2 Press **[▼]** or **[▲]** to display the "Sample Print" menu.

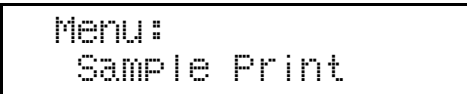

4 Press **[▼]** or **[▲]** to display "Error File(s)".

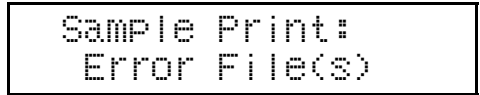

5 Press **[Enter #]**.

The following message appears on the panel display.



✎ Note

- You can check the other error logs by using **[▼]** or **[▲]**.

6 Press **[▼]** or **[▲]** to check "Error File(s)", and then press **[Enter #]**.

The following message appears on the panel display.

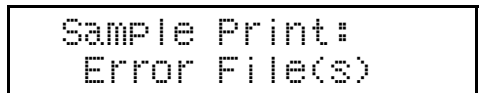

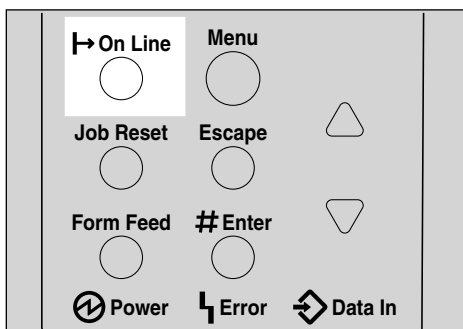
7 Press **[On Line]**.

"Ready" appears on the panel display.



Locked Print

Use this function to maintain privacy when printing confidential documents. Documents will not be printed out automatically, unless a password is entered, using the control panel after sending the print job.

Important

- Turning the printer off deletes any documents or error logs stored on the optional hard disk drive.

Limitation

- To use this function, the optional Hard Disk Drive must be installed on the printer.

Note

- If the application has a collate option, confirm that it is not selected before sending a print job. By default, locked print jobs are automatically collated by the printer driver. If the collate option is selected from the application print dialog box, more pages than intended may be printed.
- You can identify the file you want to print by the User ID and the time when the job was stored.
- The actual number of pages the printer can save depends on the contents of the print images. For example, the printer can save up to 30 jobs or 1,000 pages. It depends on the data volume.
- After the locked print file is printed, the job in the printer is deleted automatically.

Printing a Locked Print File

The following procedure describes how to print a locked print file with the PCL printer driver. For information about how to print a locked print file with the PostScript printer driver, see the PostScript 3 Operating Instructions Supplement included on the CD-ROM. For more information about RPCS printer driver, see Help.

- 1** From an application, select the menu command to print.

The print dialog box appears.

- 2** Open the Printer Properties.

- 3** From the [Job Type:] box on the [Setup] tab, select [Locked Print].

- 4** Click the [Details:] button.

- 5** In the [User ID:] box, type a User ID of up to eight alphanumeric characters.

Note

- This is used to identify the user associated with a job.
- The User ID can consist of up to eight alphanumeric (a-z, A-Z, 0-9) characters.

- 6** In the [Password:] box, type a password of four digits.

Note

- The password must be four digits (0-9).

- 7** Click [OK].

- 8** After making all desired settings, click [OK].

- 9** Start printing from the application's print dialog box.

The locked print job is sent to the printer.

- 10** On the printer's control panel, press **[Menu]**.

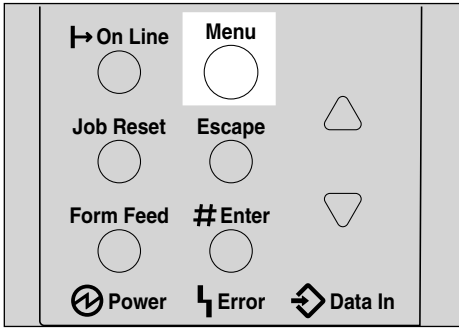

"Menu" appears on the panel display.

- 11** Press **[▼]** or **[▲]** to display "Locked Print" menu.

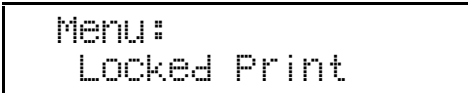

- 12** Press **[Enter #]**.

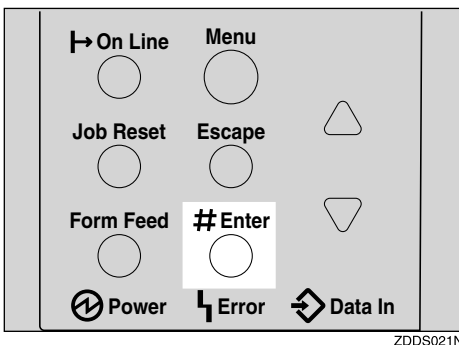

The following message appears on the panel display.

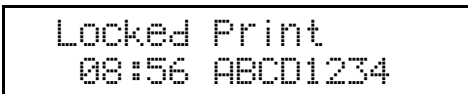

- 13** Press **[▼]** or **[▲]** to display a file you want to print, and then press **[Enter #]**.

The following message appears on the panel display.



- 14** Enter the password you entered in step **6**.

- 1** Press **[▲]** or **[▼]** to enter the leftmost digit of the password.

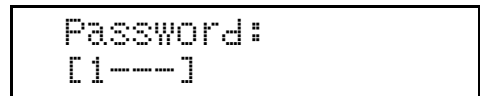

- 2** Press **[Enter #]**.

The next digit appears.



Note

- If you want to change the locked print file, press **[Escape]**.

- 3** Repeat steps **1** and **2** to enter the remaining digit of the password, and then press **[Enter #]**.

If the password is not correct, the following message appears and the panel display returns to the password menu. Reset or reenter the password.

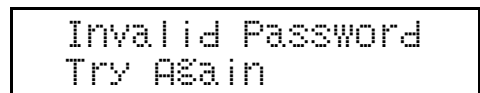

- 15** Press **[▼]** or **[▲]** to display "Print File", and then press **[Enter #]**.

Note

- If you want to change the locked print file, press **[Escape]**.

16 Press **[Enter #]**.

The following message appears on the panel display.

```
08:56 ABCD1234
Press # to Print
```

17 Press **[Enter #]** to print the file.

```
Processing...
```

3 Press **[Enter #]**.

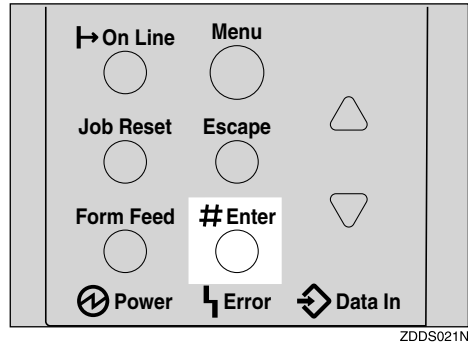

```
Locked Print:
08:56 ABCD1234
```

4

Deleting the Locked Print File

1 Press **[Menu]**.

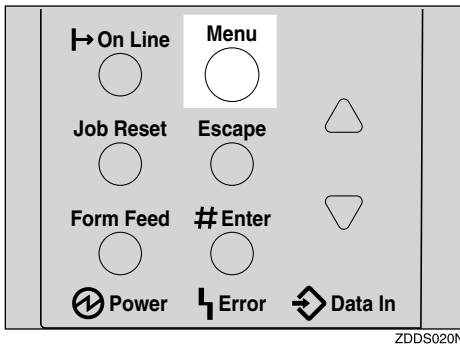

"Menu" appears on the panel display.

2 Press **[▼]** or **[▲]** to display the "Locked Print" menu.

```
Menu:
Locked Print
```

4 Press **[▼]** or **[▲]** to display the file you want delete, and then press **[Enter #]**.

```
Password:
[0---]
```

5 Enter the password of the locked print file.

1 Press **[▲]** or **[▼]** to enter the leftmost digit of the password.

```
Password:
[1---]
```

2 Press **[Enter #]**.

The next digit appears.

```
Password:
[*2---]
```

Note

- If you want to change the locked print file, press **[Escape]**.

- 3 Repeat steps 1 and 2 to enter the remaining password digits, and then press **[Enter #]**.

If the password is not correct, the following message appears and the panel display returns to the password menu. Reenter the password.

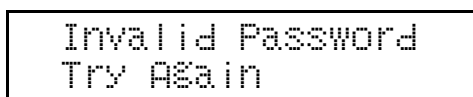

- 6 Press **[▼]** or **[▲]** to display "Delete File".



- 7 Press **[Enter #]**.

The following message appears on the panel display.

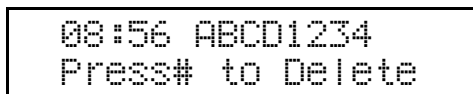

Note

- If you want to change the locked print file, press **[Escape]**.

- 8 Press **[Enter #]**.

The following message appears on the panel display.

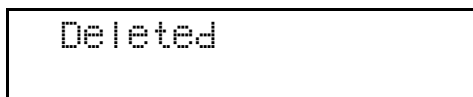

- 9 Press **[On Line]**.

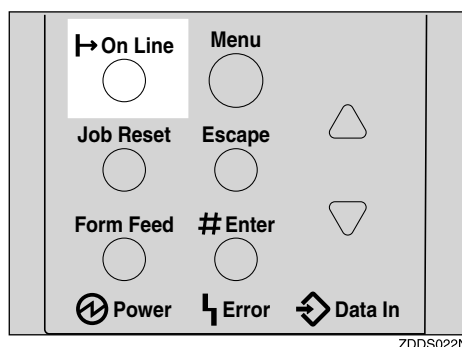

"Ready" appears on the panel display.



Checking the Error Log

Limitation

- You can view only the latest 20 error logs of all.

- 1 Press **[Menu]**.

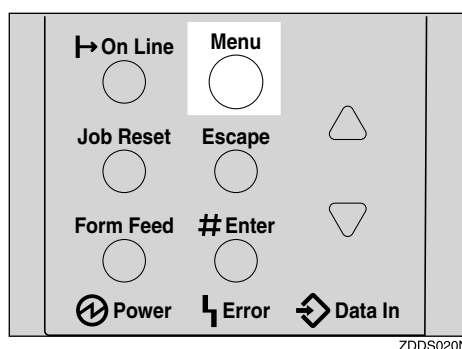

"Menu" appears on the panel display.

- 2 Press **[▼]** or **[▲]** to display the "Locked Print" menu.

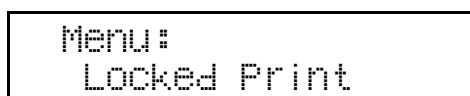

3 Press **[Enter #]**.

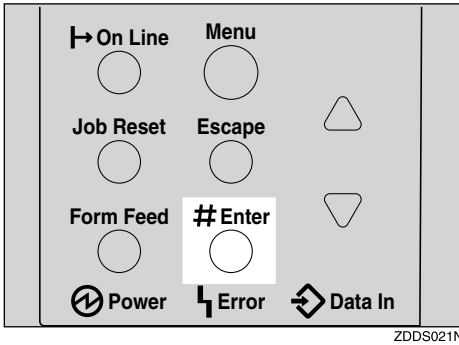

The following message appears on the panel display.



4 Press **[▼]** or **[▲]** to display "Error File(s)".

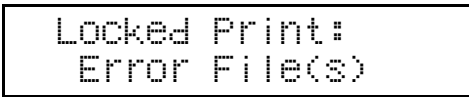

5 Press **[Enter #]**.

The following message appears on the panel display.



6 Press **[▼]** or **[▲]** to check "Error File(s)", and then press **[Escape]**.

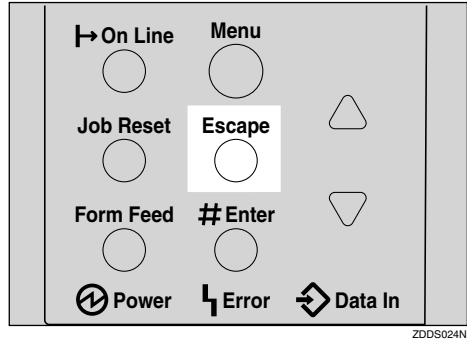

The following message appears on the panel display.

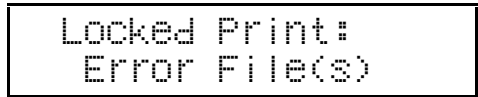

Note

- Press **[Escape]** to return to the previous menu.

7 Press **[On Line]**.

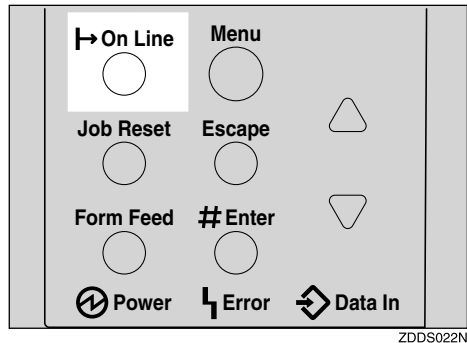

"Ready" appears on the panel display.





4

5. Troubleshooting

Error & Status Messages on the Control Panel

Messages/Second messages	Description	Solution
Call Service: EC Power Off On /If Error Reoccur Call Service	An error has occurred in the printer.	First, turn the power switch off and then on. If the message appears again, call your sales or service representative.
Change Setting Tray # /Paper Size: Paper Type:	The paper type and size setting on the tray differs from the setting on the driver.	<p>Load { paper size and type } paper with the selected feed direction into tray. Printing will not automatically resume if the paper type, size and direction setting is incorrect. Make sure that the paper size, feed directions and paper type set in the printer driver and on the control panel are the same. There are two methods to resume printing.</p> <ol style="list-style-type: none"> ① Use the control panel to set the correct paper type, size and direction of the paper in tray. ② Press 【Form Feed】 and select the tray with the control panel. <p>You can make to setting to print disregarding the error message.</p> <p> Reference See "Ppr.Size Error" in p.115 "Maintenance Menu Parameters".</p>
Cannot Check Signal in Ad hoc	The signal strength for the wireless LAN cannot be checked because "Ad hoc" is selected in "Comm.Mode" for "IEEE 802.11b" in the Host Interface menu.	Change the Transmission mode to 【Infrastructure】 in the Host Interface settings.
Close Duplex Unit Cover	The cover of the optional Duplex Unit is open.	Close the cover of the optional Duplex Unit.

Messages/Second messages	Description	Solution
Close Front Cover	The front cover is open.	Close the front cover.
Close Rear/Paper Exit Cover	The paper exit cover or the rear cover is open.	Close the paper exit cover or the rear cover.
Close Mailbox Cover	The cover of the Mailbox is open.	Close the cover of the Mailbox.
Close Upper Tray Cover	The cover of the output 1-bin Tray is open.	Close the cover of the output 1-bin Tray.
Energy Save Mode	The printer is in Energy Saver mode.	Wait for a while.
Hardware Problem DIM	An error has occurred in the printer.	First, turn the power switch off and then on. If the message appears again, call your sales or service representative.
Hardware Problem Ethernet	An error has occurred in the optional Network Interface Board.	First, turn off the power switch and then on. If the message appears again, call your sales or service representative.
		Turn off the power switch . Replace the Network Interface Board and turn on the power switch. See “ <i>Network Interface Board Type 2610</i> ” in the Setup Guide.
		Turn off the power switch, remove the Network Interface Board and turn on the power switch.  Note <input type="checkbox"/> If you remove the Network Interface Board, you cannot print over the network. You can send a print jobs to the printer only via a parallel cable connection.

Messages/Second messages	Description	Solution
Hardware Problem HDD	An error has occurred in the optional Hard Disk Drive.	First, turn the power switch off and then on, If the message appears again, call your sales or service representative.
		Turn off the power switch. Replace the Hard Disk Drive and turn on the power switch. See <i>"Hard Disk Drive Type 2600"</i> in the Setup Guide.
		Turn off the power switch. Remove the Hard Disk Drive and turn on the power switch.  Note <input type="checkbox"/> If the Hard Disk Drive is not installed, you cannot send the sample print job, locked print job and download the font to Hard Disk Drive using the PS Utility for Mac.
Hardware Problem IEEE1394	An error has occurred in the optional 1394 Interface Unit.	First, turn the power switch off and then on, If the message appears again, call your sales or service representative.
		Turn off the power switch. Replace the 1394 Interface Unit and turn on the power switch. See <i>"1394 Interface Unit Type 4510"</i> in the Setup Guide.
		Turn off the power switch, remove the 1394 Interface Unit and turn on the power switch.  Note <input type="checkbox"/> If you remove the 1394 Interface Unit, you cannot send print jobs via the 1394 Interface Unit. You can only send print jobs to the printer via the parallel cable connection.
Hardware Problem IEEE 802.11b	An error has occurred in the optional 802.11b Interface Unit.	Replace the IEEE 802.11b board.

Messages/Second messages	Description	Solution
Hardware Problem NV-RAM	An error has occurred in the printer.	First, turn the power switch off and then on. If the message appears again, call your sales or service representative.
Hardware Problem Option RAM	An error has occurred in the optional Memory Unit.	First, turn the power switch off and then on. If the message appears again, call your sales or service representative.
		Turn off the power switch, Replace the Memory Unit, and then turn on the power switch. See " <i>Memory Unit TypeB 64MB</i> " in the Setup Guide.
		Turn off the power switch, remove the Memory Unit, and then turn on the power switch. Note <input type="checkbox"/> If you remove the Memory Unit, you must set up the option with the printer driver. If you are using Windows 95/98/Me, Windows 2000/Windows XP and Windows NT 4.0, see " <i>Installing the Printer Driver and Software</i> " in the Setup Guide. <input type="checkbox"/> In this case, you might not be able to print complex print jobs.
Hardware Problem Shift Tray	An error has occurred in the shift motor of the shift tray.	First, turn the power switch off and then on. If the message appears again, call your sales or service representative.
Hardware Problem Parallel I/F	An error has occurred in the parallel I/F.	If you use the parallel I/F, replace the interface cable that caused the error. If the message appears again, contact your sales or service representative.
Hardware Problem USB	There is a problem related to the Universal Serial Bus Connection and Hardware.	First, turn the power switch off and then on, If the message appears again, call your sales or service representative.

Messages/Second messages	Description	Solution
HDD Full	The maximum HDD area size for form/font has been exceeded.	Delete the disused form/font types.
HDD Full	The optional Hard Disk Drive is full. The sample print job or locked print job to be sent from the computer is too large to store.	Delete any unnecessary stored files.
HDD Not Installed	You cannot print the sample print and the locked print jobs, because the optional Hard Disk Drive is not installed.	Install the Hard Disk Drive. See "Hard Disk Drive Type 2600" in the Setup Guide.
Hex Dump Mode	The printer is in Hex Dump Mode.	Wait for a while. If the "Hex Dump Mode" message does not change, on the panel display press [On Line] to return to the "Ready" condition.
I/O Buffer Overflow	There is too much data for the I/O buffer to handle.	Make sure the interface cable is inserted into the printer and your computer securely.
		Make sure the interface cable is not damaged or broken.
		Increase the size of the I/O buffer.
Invalid Password Try Again	The password was not entered correctly.	Wait for two seconds until the previous display appears. Then enter the password correctly.
Load Correct Size Paper /Press # to Continue	The paper size setting on the tray differs from that of actual paper size in the tray.	Load { paper size } paper of the selected feed direction and paper size into the tray. Printing will not automatically resume if the paper size and direction setting is incorrect. Make sure that the paper feed directions set in the printer driver and on the control panel are the same. There are two methods to resume printing. <ol style="list-style-type: none"> ① Use the control panel to set the correct paper size and direction of the paper in tray. Then press [Enter #]. ② Press [Form Feed] and select the tray with the control panel.

Messages/Second messages	Description	Solution
Load Paper /Paper Size: Paper Type:	The paper type and size settings for this tray do not match the size and type of paper actually loaded.	Load paper into the tray indicated, then press [Enter #] to resume printing. Or press [Form Feed] and select the tray that holds a different type of paper. To cancel printing, press [Job Reset] . Then press [Enter #] .
Load Paper Tray # /Paper Size: Paper Type:	There is no paper left in this tray.	Load paper into the tray indicated.
Menu Protected Cannot Change	The menu is protected and the settings cannot be changed.	Wait for two seconds until the previous display appears.
No Files Exist	There are no files available for the sample print job or the locked print job.	Wait for two seconds until the previous display appears.
Offline	The printer is offline.	If you want to bring the printer online. Press [On Line] .
Output Tray Changed	The output tray has been changed. The tray in the paper feed path is not set correctly when the printer receives the print job.	Select the output tray correctly.
Paper Invalid for Duplex:Tray # /Change Setting or Form Feed	A paper setting for the selected tray is not supported for duplex printing. #: tray number	Change the paper setting with the control panel. Or press [Form Feed] several times until a tray with supported paper settings appears on the panel display. Or press [Job Reset] to cancel the print job.
P= XX I= XXXXXXXX Power Off On /If Error Reoccur Call Service	A controller error. The SC number indicates the problem.	First, turn the power switch off and then on. If the message appears again, call your sales or service representative.
Print Overrun	A Print overrun occurred on a file being printed. Only a part of the data on the page will be printed, and the print job is suspended, or the current print job has been canceled.	To print the image correctly, add memory to the printer or reduce the resolution of the image.
Printing...	————	Wait for a while.
Processing...	The printer is processing internally.	Wait for a while.

Messages/Second messages	Description	Solution
Ready	The printer is online and ready to make prints.	If you want to take the printer offline, press [On Line] .
Remove Misfeed Duplex Unit /Open Duplex Unit Cover	There is misfeed in the Duplex Unit.	Remove the misfed paper.
Remove Misfeed Internal Path /Open Front Cover	There is a misfeed in the printer.	Remove the misfed paper. See p.82 "Removing Misfed Paper".
Remove Misfeed Mailbox /Open Mailbox Cover	There is a misfeed in the Mailbox.	Remove the misfed paper.
Remove Misfeed Paper Exit Cover /Open Paper Exit Cover	There is a misfeed in the paper exit cover.	Remove the misfed paper.
Remove Misfeed Paper Tray /Remove Misfeed Paper Tray	There is a misfeed in the printer.	Remove the misfed paper. See p.82 "Removing Misfed Paper".
Remove Misfeed Upper Tray Unit /Open Upper Tray Cover	There is a misfeed in the upper tray unit.	Remove the misfed paper.
Remove Paper All Output Trays	All output trays are full, and the print job is suspended.	Remove paper from all output trays, and the print job will be resumed automatically.
Remove Paper from Upper Tray	The upper tray is full, and the print job is suspended.	Remove paper from the upper tray, and the print job will be resumed automatically.
Remove Paper Mailbox Tray #	The Mailbox is full, and the print job is suspended.	Remove paper from the Mailbox, and the print job will be resumed automatically.
Remove Paper Standard Tray	The standard tray is full, and the print job is suspended.	Remove paper from the standard tray, and the print job will be resumed automatically.
Replace Maintenance Kit	It is time to replace parts included in the Maintenance Kit.	Replace parts. See p.144 "MAINTENANCE KIT Type 2600".

Messages/Second messages	Description	Solution
Replace Toner Cartridge	The toner cartridge is not set correctly or toner is almost run out.	Set the toner cartridge correctly. See p.90 "Replacing the Toner Cartridge".
	The toner dust is full.	Prepare a new toner cartridge. If the image density gets too light, replace the toner cartridge with a new one. See p.90 "Replacing the Toner Cartridge".
Reset Fusing Unit Correctly	The fusing unit is not set correctly.	Set the fusing unit correctly, or set the proper fusing unit.
Reset Toner Cartridge	The toner cartridge is not set correctly.	Set the toner cartridge correctly. See p.90 "Replacing the Toner Cartridge".
	The toner cartridge is not set installed.	If the cartridge is installed, close the front cover and turn the off power switch and then on. If the message appears again, contact your sales or service representative.
Reset Tray # Correctly	The input paper tray is not set correctly.	Set the input paper tray correctly.
Resetting Job...	The print job is being reset.	Wait for a while.
SC XXX-X Power Off On If Error Reoccur Call Service	An error has occurred.	First, turn the power switch off and then on. If the message appears again, call your sales or service representative.
SC2001	An error has occurred in the resident font RAM.	First, turn the power switch off and then on. If the message appears again, call your sales or service representative.
Toner Is Almost Empty	The toner is almost run out.	Prepare a new toner cartridge. If the image density gets too light, replace the toner cartridge with a new one. See p.90 "Replacing the Toner Cartridge".
Waiting...	The printer is waiting for the next print job.	Wait for a while.
Warming Up...	The printer is warming up or toner is being supplied.	Wait until the panel display change the "Ready".

Getting Printer Information over the Network

Printer current status

You can check the printer's status using the telnet command.

❖ telnet

Use the status command.

❖ UNIX

Use the lpq or lpstat command or stat parameter of rsh, rcp, or ftp.

🔍 Reference

For more information, see “Remote Maintenance by Telnet (mshell)” in the Network Printing Guide is provided on the CD-ROM labeled “Operating Instructions”.

Messages	Description	Comments
Call Service Center	There is a malfunction in the printer.	Turn the printer off and on.
Cover Open: Duplex Unit	The cover of the optional Duplex Unit is open.	Close the cover of the optional Duplex Unit.
Cover Open: Front Cover	Close the front cover.	Close the front cover.
Cover Open: Mailbox	The cover of the Mailbox is open.	Close the cover of the Mailbox cover.
Cover Open: Paper Exit/Rear	The paper exit cover or the rear cover is open.	Close the paper exit cover or the rear cover.
Cover Open: Upper Tray	The upper tray cover is open.	Close the upper tray cover.
Empty: Toner	The toner cartridge is empty.	Replace the new toner cartridge.
Energy Saver Mode	The printer is in Energy Save Mode.	Wait for a while.
Energy Saver Mode 1		
Error: HDD Board	An error has occurred in the optional Hard Disk Drive.	First, turn the power switch off and then on. If the message appears again, call your sales or service representative.
IEEE 802.11b Card Error	The optional IEEE 802.11b board or the optional IEEE 802.11b card is not installed.	Install the optional IEEE 802.11b board or the optional IEEE 802.11b card.
IEEE 802.11b Card or Board Error	An error has occurred in the optional IEEE 802.11b board or the optional IEEE 802.11b card	First, turn the power switch off and then on. If the message appears again, set the optional IEEE 802.11b board. If the message still appears, call your sales or service representative.

Messages	Description	Comments
NVRAM Error	An error has occurred in the printer.	First, turn the power switch off and then on. If the message appears again, call your sales or service representative.
Error: IEEE 1394 Board	An error has occurred in the optional 1394 Interface Unit.	First, turn the power switch off and then on. If the message appears again, call your sales or service representative.
Error: Memory Switch	An error has occurred in printer.	First, turn the power switch off and then on. If the message appears again, call your sales or service representative.
Error: Optional RAM	An error has occurred in the optional Memory Unit.	First, turn the power switch off and then on. If the message appears again, call your sales or service representative.
Error: Parallel I/F Board	An error has occurred in the parallel interface board.	First, turn the power switch off and then on. If the message appears again, call your sales or service representative.
Full: Mailbox Tray 1	The output tray 1 of the optional Mailbox is full.	Remove paper from the output tray 1 of the optional Mailbox.
Full: Mailbox Tray 2	The output Tray 2 of the optional Mailbox is full.	Remove paper from the output Tray 2 of the optional Mailbox.
Full: Mailbox Tray 3	The output Tray 3 of the optional Mailbox is full.	Remove paper from the output Tray 3 of the optional Mailbox.
Full: Mailbox Tray 4	The output tray 4 of the optional Mailbox is full.	Remove paper from the output tray 4 of the optional Mailbox.
Full: Output Tray(s)	All output trays are full.	Remove paper from all output trays.
Full: Standard Output Tray	The output tray is full.	Remove paper from output trays.
Full: Waste Toner	The toner is almost run out.	Prepare a new toner cartridge.
Low: Toner	The toner cartridge is not set correctly or toner is almost running out.	Set the toner cartridge correctly.
Mismatch: Paper Size	The paper size setting of the tray differs from that of actual paper size in the tray.	Load paper of the indicated paper size into the paper tray being used. See p.25 "Paper and Other Media Supported by This Printer".

Messages	Description	Comments
Mismatch: Paper Size and Type	The paper type setting of the tray differs from that of actual paper type in the tray.	Load paper of the indicated paper size and type into the paper tray being used. See p.25 "Paper and Other Media Supported by This Printer".
Mismatch: Paper Type	The paper type setting of the tray differs from that of actual paper type in the tray.	Load paper of the indicated paper type into the paper tray being used. See p.25 "Paper and Other Media Supported by This Printer".
No Paper: Input Tray(s)	There is no paper of the indicated paper size in the paper tray.	Load paper into the paper tray. See p.37 "Loading Paper in the Paper Tray".
Not Detected: Fusing Unit	The fusing unit is not set correctly.	Set the fusing unit correctly. If the message appears again, call your sales or service representative.
Not Detected: Input Tray(s)	The input tray is not set correctly.	Set the input tray correctly. If the message appears again, call your sales or service representative.
Not Detected: Toner Cartridge	The toner cartridge is not set correctly.	Set the toner cartridge correctly. If the message appears again, call your sales or service representative.
Paper Misfeed: Duplex Unit	There is misfeed in the Duplex Unit.	Remove the misfed paper. See p.87 "When "Remove Misfeed Duplex Unit" Appears".
Paper Misfeed: Front Cover	There is misfeed in the printer.	Remove the misfed paper. See p.83 "When "Remove Misfeed Internal Path/Open Front Cover" Appears".
Paper Misfeed: Input Tray	There is misfeed in the printer.	Remove the misfed paper. See p.82 "When "Remove Misfeed Paper Tray" Appears".
Paper Misfeed: Mailbox	There is misfeed in the Mailbox.	Remove the misfed paper. See p.89 "When "Remove Misfeed Mailbox" Appears".
Paper Misfeed: Output Tray	There is misfeed in output tray.	Remove the misfed paper. See p.84 "When "Remove Misfeed Paper Exit Cover" Appears".
Ready	The printer is on line and ready to make prints.	—

Messages	Description	Comments
Replace Maintenance Kit	It is time to replace parts included in the Maintenance Kit.	Replace parts. See p.144 "MAINTENANCE KIT Type 2600".
Shift Tray Error	An error has occurred in the 1-bin Shift Sort Tray.	First, turn the power switch off and then on. If the message appears again, call your sales or service representative.
Size Media Mismatch	The paper size setting of the tray differs from that of actual paper type in the tray.	Load paper of the indicated paper size and type into the paper tray being used. See p.25 "Paper and Other Media Supported by This Printer".
Size Mismatch	The paper size setting of the tray differs from that of actual paper type in the tray.	Load paper of the indicated paper size and type into the paper tray being used. See p.25 "Paper and Other Media Supported by This Printer".
USB I/F Error	An error has occurred in the USB interface.	First, turn the power switch off and then on. If the message appears again, call your sales or service representative.
Warming Up/Adjusting...	The printer is warming up or toner is being supplied.	Wait until the panel display change the "Ready".

Printer configuration

You can check the printer configuration using telnet.

❖ telnet

Use the info command.

❖ UNIX

Use the info parameter of rsh, rcp, or ftp.

🔍 Reference

For more information, see “Remote Maintenance by Telnet (mshell)” in the Network Printing Guide is provided on the CD-ROM labeled “Operating Instructions”.

📝 Note



























- “*” (asterisk) is displayed with the current setting.
- Regarding *1–*6, see below table.

Item	Description
Printer System	Version of the printer
Network Board	Version of the network board
Input Tray	
No.	ID number of the paper tray
Name	Name of the paper tray ^{*1}
PaperSize	Paper size loaded in the paper tray ^{*2}
Status	Current status of the paper tray ^{*3}
Output Tray	
No.	ID number of the output tray
Name	Name of the output tray ^{*4}
Status	Current status of the output tray ^{*5}
Emulation	
No.	ID number of the emulation used by the printer
Name	Name of the emulation used in the printer
Version	Version of the emulation
Program	
No.	ID number of the program
Name	Name of the program

❖ *1 Input Tray: Name

Name	Description
Tray X	Name of installed paper tray. (X is the number of tray.)
Bypass Tray	Bypass Tray

❖ *2 Input Tray: Paper Size

Paper Size	Description
A3 (297 × 420)	A3 
B4JIS (257 × 364)	B4 
A4 (297 × 210)	A4 
A4 (210 × 297)	A4 
B5JIS (257 × 182)	B5 
B5JIS (182 × 257)	B5 
A5 (210 × 148)	A5 
A5 (148 × 210)	A5 
A6 (105 × 148)	A6 
11 × 17	279 × 432 
8 ¹ / ₂ × 14	LG/216 × 356 
11 × 8 ¹ / ₂	LT/279 × 216 
8 ¹ / ₂ × 11	LT/216 × 279 
5 ¹ / ₂ × 8 ¹ / ₂	140 × 216 
FRI	Custom Size
10 ¹ / ₂ × 7 ¹ / ₄	10 ¹ / ₂ × 7 ¹ / ₄ 
7 ¹ / ₄ × 10 ¹ / ₂	7 ¹ / ₄ × 10 ¹ / ₂ 
8 ¹ / ₄ × 13	8 ¹ / ₄ × 13 
8 ¹ / ₂ × 13	8 ¹ / ₂ × 13 
4 ¹ / ₈ × 9 ¹ / ₂	4 ¹ / ₈ × 9 ¹ / ₂ 
3 ⁷ / ₈ × 7 ¹ / ₂	3 ⁷ / ₈ × 7 ¹ / ₂ 
110 × 220	4 ¹ / ₃ × 8 ³ / ₄ 
C5 Env(162 × 229)	C5 Env 
8 × 13	203 × 330 
C6 Env(114 × 162)	C6 Env 
8K (267 × 390)	8K 
16K (267 × 195)	16K 
16K (195 × 267)	16K 
NCS	There is no tray.
**	The paper size is not selected.

❖ ***3 Input Tray: Status**

Status	Description
Normal	—
NoTray	There is no paper tray
PaperEnd	There is no paper in the paper tray

❖ ***4 Output Tray: Name**

Name	Description
Standard Tray	Output Tray
1-bin Shift Tray	1-bin Shift Sort Tray
Mailbox Tray 1-4	Mailbox output tray 1-4



❖ ***5 Output Tray: Status**

Status	Description
Normal	----
PaperExist	There is paper in the output tray
OverFlow	Output tray is full of paper
Error	Other error

Printer Does Not Print

Possible Cause	Solutions
Is the power on?	Confirm that the cable is securely plugged into the power outlet and the printer. Turn on the power switch.
Does the On Line indicator stay on?	Press [On Line] so the indicator lights.
Does the Error indicator stay red?	Check the error message on the panel display and take the required action.
Is paper loaded?	Load paper into the paper tray or on the Bypass Tray. See p.37 "Loading Paper and Other Media".
Can you print a configuration page?	If you cannot print a test page, it probably indicates a printer malfunction. You should contact your sales or service representative. See p.110 "List/Test Print Menu". If you can print a test page but cannot get the printer to print when you issue a print command from the computer, it probably means there is a problem with the computer. Note that large or complex data might take a long time to be printed.
Is the interface cable connecting the printer to the computer connected securely?	Connect the interface cable properly. If there are any connectors or screws, confirm that they are fastened securely.
Are you using the correct interface cable?	The type of interface cable you should use depends on the computer. Be sure to use the correct one. If the cable is damaged or worn, replace it with a new one.
Is the paper feed roller clean?	Clean the paper feed roller if it is dirty. See p.94 "Cleaning the Paper Feed Roller".

Possible Cause	Solutions
Is the Data In indicator blinking or lit after starting the print job?	<p>If not blinking or lit, the data is not being sent to the printer.</p> <p>❖ If the printer is connected to the computer using the interface cable</p> <p>Make sure the following printer port settings are correct:</p> <ul style="list-style-type: none"> • For a parallel port connection, port LPT1 or LPT2 should be set. • For a USB port connection, port USB00 (n) *¹ should be set. • For a IEEE 1394 (SCSI print) port connection, port 1394_00(n) *¹ should be set. <p>*¹ (n) is the number of printers connected.</p> <ul style="list-style-type: none"> • Windows 95/98/Me <ol style="list-style-type: none"> ① Click [Start], point to [Settings] and then click [Printers]. ② Click to select the icon of the printer. Next, on the [File] menu, click [Properties]. ③ Click the [Details] tab. ④ Check the [Print to the following port] box to confirm that the correct port is selected. • Windows 2000 <ol style="list-style-type: none"> ① Click [Start], point to [Settings] and then click [Printers]. ② Click to select the icon of the printer. Next, on the [File] menu, click [Properties]. ③ Click the [Port] tab. ④ Check the [Print to the following port] box to confirm that the correct port is selected. • Windows XP <ol style="list-style-type: none"> ① Access the [Printers and Faxes] window from [Start] on the taskbar. ② Click to select the icon of the printer. Next, on the [File] menu, click [Properties]. ③ Click the [Port] tab. ④ Check the [Print to the following port(s)] box to confirm that the correct port is selected. • Windows NT 4.0 <ol style="list-style-type: none"> ① Click [Start], point to [Settings] and then click [Printers]. ② Click to select the icon of the printer. Next, on the [File] menu, click [Properties]. ③ Click the [Port] tab. ④ Check the [Print to the following port] box to confirm that the correct port is selected. <p>❖ Network Connection</p> <p>Contact your network administrator.</p>

Possible Cause	Solutions
Do you print via a network?	<p>Confirm that the "Ethernet" setting is correct from the control panel. See p.130 "Host Interface Menu".</p> <p>The setting governs the data transfer speed used by the Network Interface Board. Three options are available:</p> <ul style="list-style-type: none"> • Auto (default) • 100 Mbps • 10 Mbps <p> Note</p> <p><input type="checkbox"/> For more information about the appropriate setting to use on your network, contact your network administrator.</p>
If you use IEEE 1394, check for the followings.	<ol style="list-style-type: none"> ① Make sure the 1394 Interface Unit is installed properly. ② Make sure the IEEE 1394 cable is connected properly. ③ Restart the computer. If the problem still exists when SCSI print is used with Windows 2000 and Windows XP, go to step ④. ④ Disconnect all the IEEE 1394 cables from the computer. ⑤ If you uninstall the printer driver when the printer is connected to a computer with "SCSI print", the printer driver may not be uninstalled properly. To uninstall the driver properly, use the IEEE 1394 Printer Removal Utility on the CD-ROM that comes with the printer. Stored in: CD-ROM labeled "Operating Instructions"\DRIVERS\UTILITY\1394\ <p> Note</p> <p><input type="checkbox"/> For more information about the IEEE 1394 Printer Removal Utility, see the README file in the same folder as the program.</p> <ol style="list-style-type: none"> ⑥ Restart the computer.
How is the signal strength when using the wireless LAN?	<p>Check the signal strength from the Maintenance menu. If the signal is weak, move to a place with better signal strength or remove objects that are possibly interfering with data transmission.</p> <p>The signal strength appears only in infrastructure mode. If you are using the ad hoc mode, the signal strength does not appear on the control panel. For more information about displaying the signal strength, see p.120 "Displaying the Signal Strength".</p>

 **Note**

- If you cannot solve the problem by taking the preceding actions, contact your sales or service representative.

Other Printing Problems

Status	Possible Causes, Descriptions, and Solutions
The print side of the page is a hazy gray.	Adjust the image density. See p.101 "Making Printer Settings with the Control Panel".
	If paper is curled, correct it.
	If you continuously print data that contains extremely small amount of words or images in the printable area, the printed side of the page could be a hazy gray. Adjust the image density. See p.101 "Making Printer Settings with the Control Panel".
	Shaking the toner cartridge after pulling out the toner seal can cause dirt on paper surfaces, toner spillage, or printer failure. If you have accidentally shaken the toner cartridge, print some pages (about 50 pages) until the dirt disappear.
Image quality varies when printing on thick paper or on OHP transparencies.	Switch to Thick Paper mode. <ul style="list-style-type: none"> • When toner is not fused enough, set it to "On". • When the image is blurred, set it to "----". See p.101 "Making Printer Settings with the Control Panel".
Some parts of the print image are not clear.	Make the image density darker. See p.101 "Making Printer Settings with the Control Panel".
	If Toner Saving mode is selected using the control panel, the whole image gets lighter.
The print image is not clear.	Due to a sudden change in temperature, condensation might appear inside the printer, reducing print quality. If this occurs, when you move the printer from a cold room to a warmer room, do not use the printer until it acclimatizes to the temperature.
Nothing is printed on the paper.	Check if the tape of the toner cartridge is completely removed. Be sure to remove the tape completely when replacing the toner cartridge. See p.90 "Replacing the Toner Cartridge". Note <input type="checkbox"/> If the power switch is turned on with the tape still attached to the toner cartridge, the printer might be damaged.
Multiple pages are fed through the printer at once.	Clean the friction pad if it is dirty. See p.93 "Cleaning the Friction Pad".
	Remove all paper from the tray and fan it gently to get air between the sheets. After that, load it back into the tray.
The image is printed on the reverse side of the paper.	Set the paper the other way up.

Status	Possible Causes, Descriptions, and Solutions
Paper misfeeds occur frequently.	<p>Check the paper size settings. The size set with the paper size dial might be different from the actual paper size. Make the correct dial setting.</p> <p>See p.37 "Loading Paper and Other Media".</p>
	<p>Use the recommended paper. Avoid using curled, folded, wrinkled, perforated or glossy paper. See p.35 "Paper not supported by this printer".</p>
	<p>Clean the paper feed roller, friction pad and/or registration roller, if they are dirty. See p.94 "Cleaning the Paper Feed Roller".</p>
	<p>Thin paper, if printed on both sides, may curl up at the corners and get wrinkled and clogged. Select [Curl Prevention] [ON] from the [Maintenance] menu.</p>
The control panel error message stays on after removing the misfed paper.	<p>Open the front cover of the printer and then close it. See p.82 "Removing Misfed Paper".</p>
Output are not delivered to the selected tray you require.	<p>Check the paper size settings. The size selected with the paper size dial might be different from the actual paper size. Make the correct dial setting.</p> <p>See p.37 "Loading Paper and Other Media".</p>
	<p>When using the Bypass Tray, set the paper size using the control panel.</p> <p>See p.37 "Loading Paper and Other Media".</p>
	<p>When you are using a Windows operating system, the printer driver settings override those set using the control panel. Set the desired output tray using the printer driver. See the driver's online Help file.</p>
The printed image is different from the image on the computer.	<p>When you use some functions, such as enlargement and reduction, the layout of the image might be different from that shown in the computer display.</p>
It takes too much time to resume printing.	<p>The data is so large or complex that it takes time to process it. If the Data In indicator is blinking, the data processing is being done. Just wait until it resumes.</p>
	<p>Changing the paper feed direction may sometimes reduce the time to resume printing.</p>
The image is printed in the wrong orientation.	<p>Set the correct orientation under the "PCL Menu" with the control panel. See p.137 "PCL Menu".</p>
	<p>Confirm that the setting of orientation has been set in the application you use.</p>
	<p>Set the correct paper size and feed direction that matches tray settings on the RPCS printer driver.</p>
Part of the image cannot be printed.	<p>A paper size which is smaller than that selected in the application is used for printing. Load the correct size of paper.</p>

Status	Possible Causes, Descriptions, and Solutions
Network configurations you have made do not become effective.	Print a configuration page and check the network settings.
Printing from a Macintosh with the network standard model is slow.	Set the Ethernet speed of the machine to 10Mbps. If you want to use the machine with Macintosh at the Ethernet speed of 100Mbps, call your sales or service representative. See "Ethernet" in the Network Setup menu.

 **Note**

- If the problem cannot be solved, contact your sales or service representative.

Removing Misfed Paper

When a paper misfeed occurs, an error message appears on the panel display. The procedure you should follow to remove misfed paper depends on the location of the misfeed, which is indicated on the panel display.

⚠ CAUTION:

- *When removing misfed paper, do not touch the fusing section because it becomes very hot.*

⚠ Important

- Check the following points if paper continues to misfeed.
 - Confirm that the setting of the paper size dial matches the size and feed direction of the paper loaded in the paper tray.
 - If the friction pad or the paper feed roller is dirty, clean it. For more information, see p.93 “Cleaning the Friction Pad”.
 - Confirm that the toner cartridge is set correctly.
- If a paper misfeed still occurs, contact your sales or service representative.
- Forcefully removing misfed paper may cause paper to tear and leave scraps of paper in the printer.
- Do not leave any scraps of paper in the printer.

When “Remove Misfeed Paper Tray” Appears

⚠ Important

- Forcefully removing misfed paper may cause paper to tear and leave scraps of paper in the printer. This might cause a misfeed and damage the printer.

- 1** Lift the paper tray slightly. Pull it out until it stops, and then remove the misfed paper.

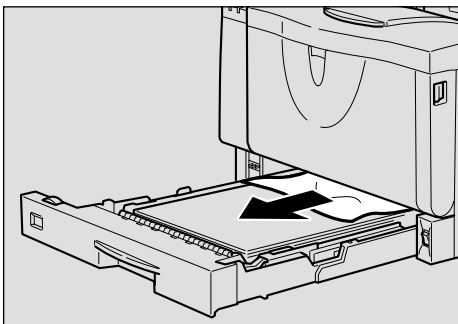

ZCEY280J

- 2** Carefully slide the paper tray into the printer until it stops.

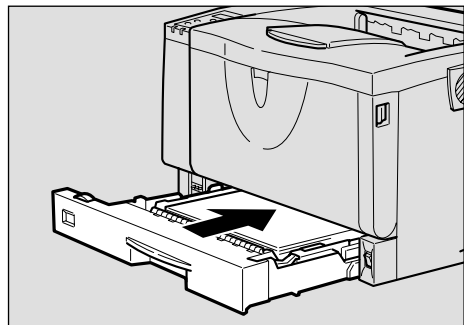

ZGDY290J

⚠ Important

- Do not slide the paper tray in with force. If you do, the front and side guides might move.

- 3** Open the front cover by pushing the front cover release button, and then close it to reset the misfeed condition.

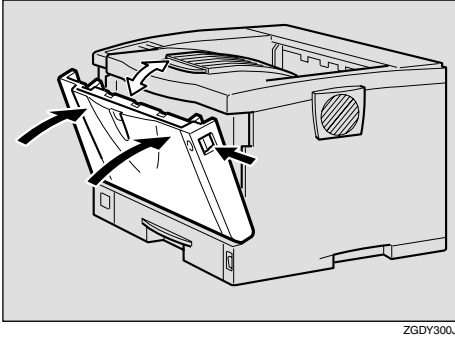

Note

- You can apply this procedure for both the paper tray and the optional Paper Feed Unit.
- To reset the misfeed condition, open and close the front cover, then the indicator will be off.

When "Remove Misfeed Internal Path/Open Front Cover" Appears

Important

- Forcefully removing misfed paper may cause paper to tear and leave scraps of paper in the printer. This might cause a misfeed and damage the printer.

- 1** Open the front cover by pushing the front cover release button.

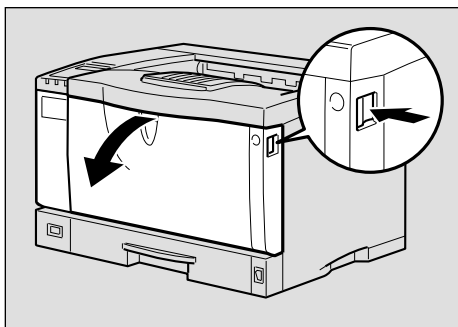

- 2** While lifting the front side of the toner cartridge, pull it out of the printer.

Important

- Be sure to put the toner cartridge on a stable, flat surface.
- Do not hold the toner cartridge upside down or stand it vertically.

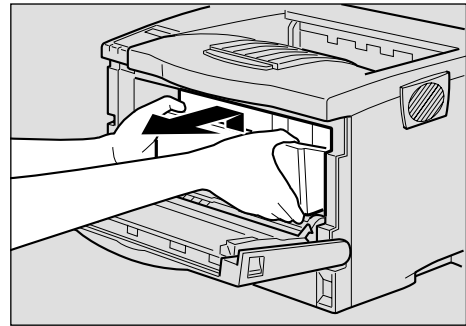

- 3** Pull out the misfed paper by holding both sides of paper. Be careful not to get toner dust on your hands or clothes.

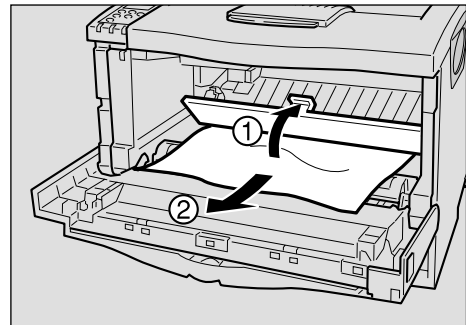

- 4** Holding the grips of the toner cartridge, insert it into the printer until it stops.

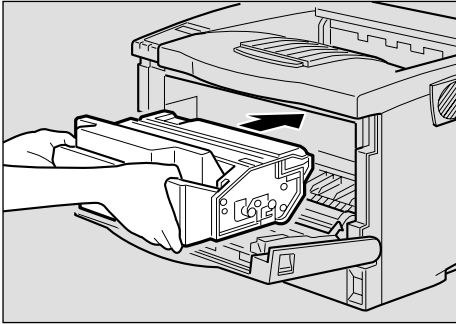

ZGDT120J

- 5** Push down the toner cartridge to settle it in appropriate position.

5

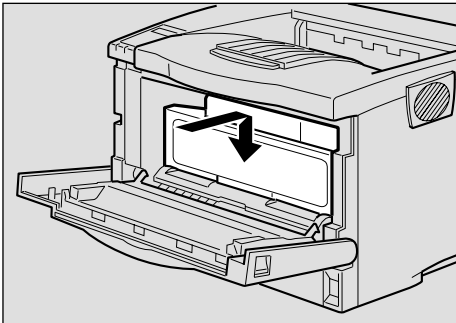

ZGDT140J

- 6** Close the front cover.

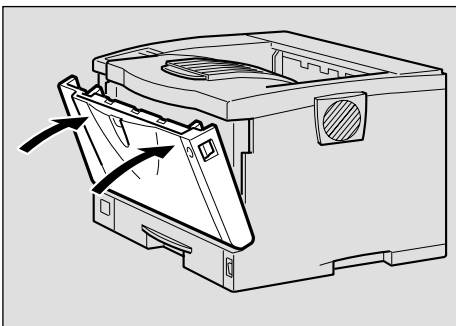

ZGDH130J

Important

- If paper is fed from the Bypass Tray, be sure to remove all the paper from the Bypass Tray and close it before opening the front cover.

When "Remove Misfeed Paper Exit Cover" Appears

CAUTION:

- When removing misfed paper, do not touch the fusing section because it becomes very hot.
- The fusing unit becomes very hot. When installing the new fusing unit, turn off the printer and wait about an hour. After that, install the new fusing unit. Not waiting for the unit to cool down can result in a burn.

Important

- Forcefully removing misfed paper may cause paper to tear and leave scraps of paper in the printer. This might cause a misfeed and damage the printer.

- 1** If you installed the 1-bin Shift Sort Tray, slide the upper tray out from it. If you installed the Mailbox, slide the output tray into lower slide out from it.

The following procedures are example of Mailbox.

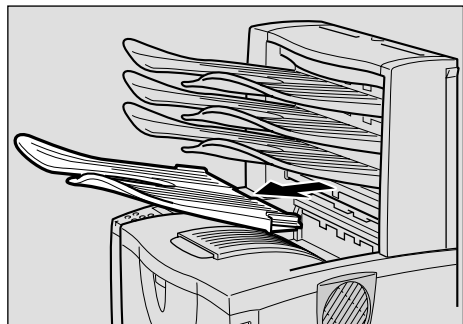

ZGDY370J

- 2** Open the paper exit cover.

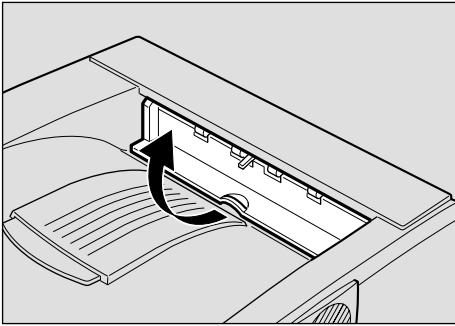

ZGDY390J

- 3** Remove the misfed paper.

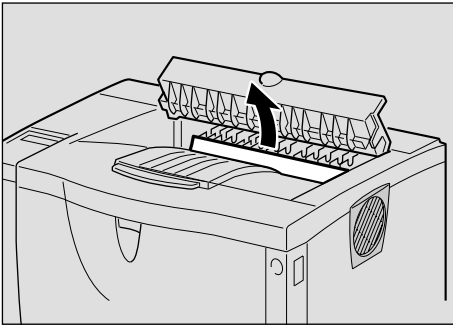

ZGDY380J

- 4** Close the paper exit cover until it clicks.

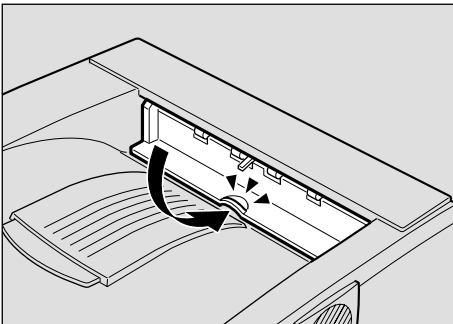

ZGDY400J

- 5** If the misfed paper is in the fusing unit, remove it.

- 1** Open the rear cover by pushing the two knobs.

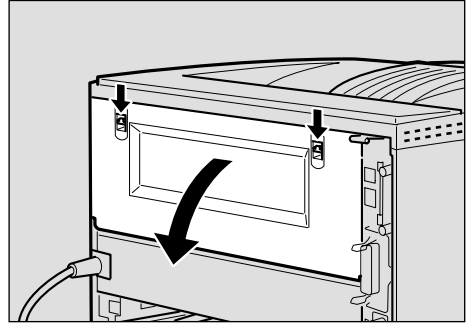

ZGDY210J

- 2** Remove the rear cover in a horizontal direction.

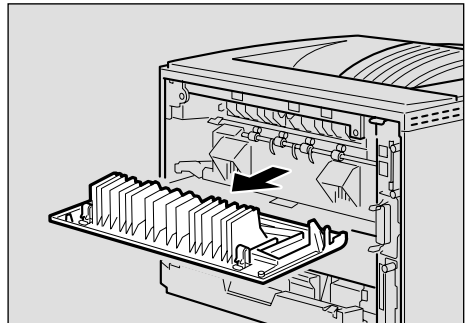

ZGDY220J

- 6** Lift the lock levers of the fusing unit as shown in the illustration.

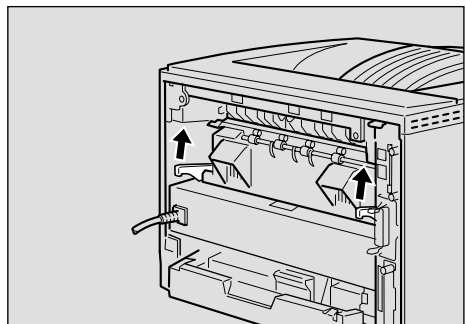

ZGDY222N

7 Pull the fusing unit out.

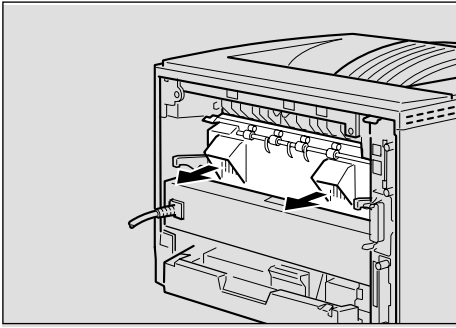

ZGDx223N

10 Push the lock levers of the fusing unit down until it clicks.

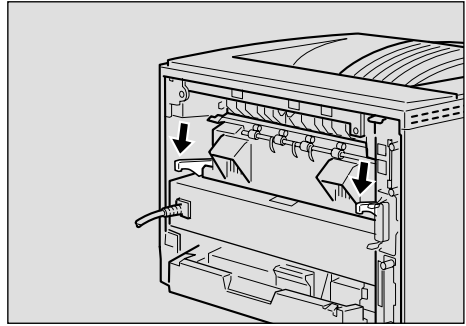

ZGDx225N

8 While holding the tab, remove the misfed paper.

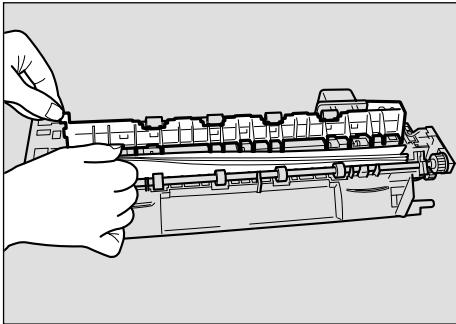

ZGDY410J

11 Insert the rear cover to the inside grooves on both sides of the printer in a horizontal direction.

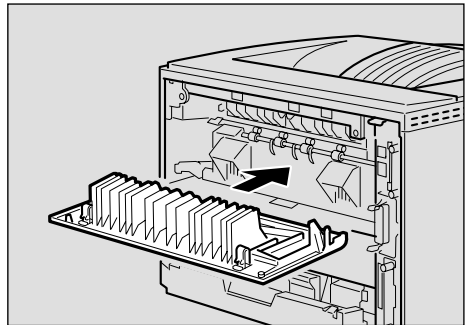

ZGDx221J

Important

- Do not touch the metal part of the fusing unit. It becomes very hot. Touching it could result in a burn.

9 Insert the fusing unit until it stops.

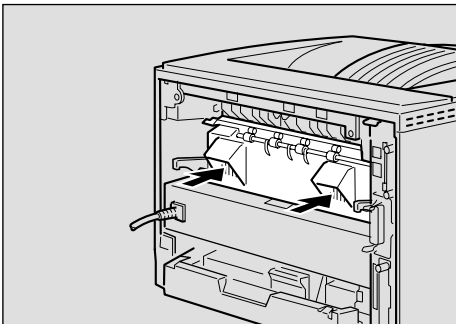

ZGDx224N

12 Close the rear cover.

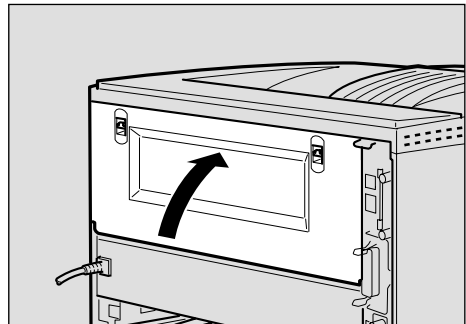

ZGDx211N

When "Remove Misfed Duplex Unit" Appears

⚠ CAUTION:

- When removing misfed paper, do not touch the fusing section because it becomes very hot.

⚠ Important

- ❑ Forcefully removing misfed paper may cause paper to tear and leave scraps of paper in the Duplex Unit. This might cause a misfeed and damage the printer.

1 Remove the misfed paper inside of the cover.

1 Open the rear cover of the Duplex Unit.

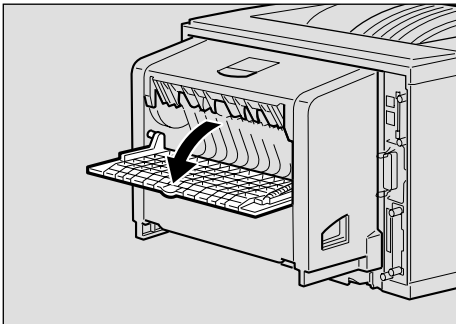

2 Remove the misfed paper.

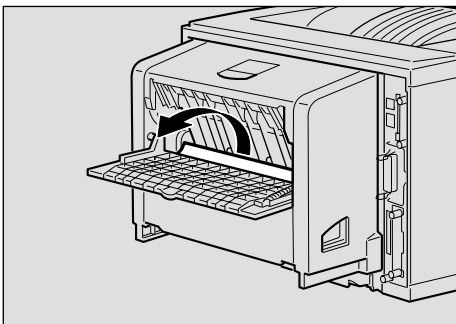

3 Close the rear cover of the Duplex Unit.

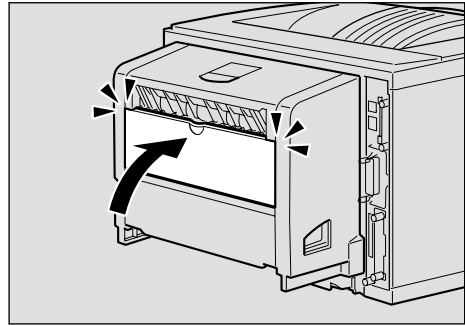

4 While lifting the lever (1), open the cover of the Duplex Unit (2).

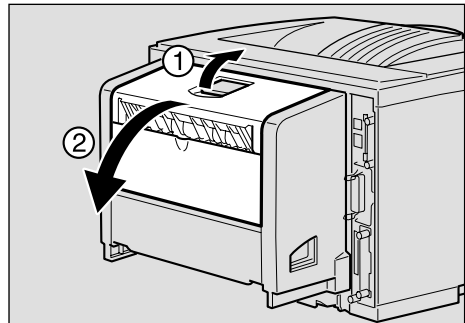

5 Remove the misfed paper.

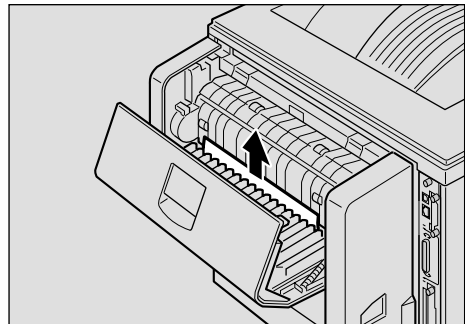

6 Close the cover of the Duplex Unit.

If the error message appears again, go to step **2**.

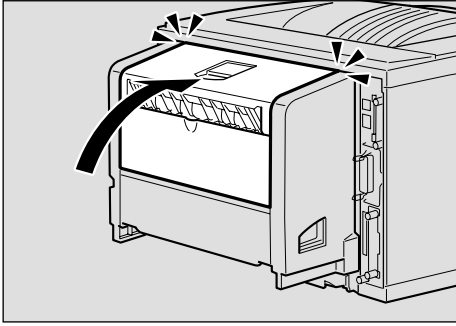

ZGDY360J

2 Pull the Duplex Unit out of the printer until it stops, and remove the misfed paper.

- 1** Push down the lever on the right side of the Duplex Unit (①) and pull it out until it stops (②).

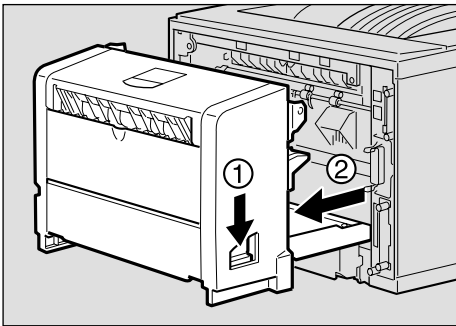

ZGDX320J

2 Lift the guide board inside the Duplex Unit, and remove the misfed paper.



ZGDY440J

Important

- When A5 paper misfeeds, you might not be able to remove it by pulling the Duplex Unit out. In this case, pull the paper tray out and remove the paper.

3 While aligning the power cord with the groove of the left side of the Duplex Unit, insert the Duplex Unit into back of the printer aligning the rails inside of the printer until it is connected.

If the error message appears again, the misfed paper might be left in the printer. Confirm that any torn paper scraps are not in the inside of the printer. For more information, see p.83 "When "Remove Misfeed Internal Path/Open Front Cover" Appears".

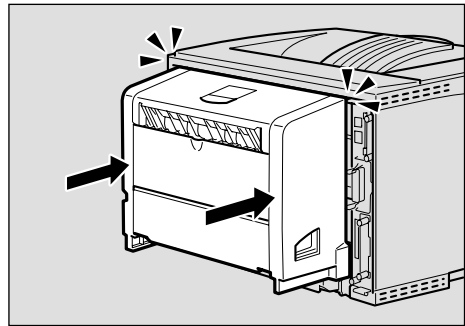

ZGDX240J

When "Remove Misfeed Mailbox" Appears

⚠ Important

- ❑ Forcefully removing misfed paper may cause paper to tear and leave scraps of paper in the Mailbox. This might cause a misfeed and damage the printer.

1 Open the cover of the Mailbox.

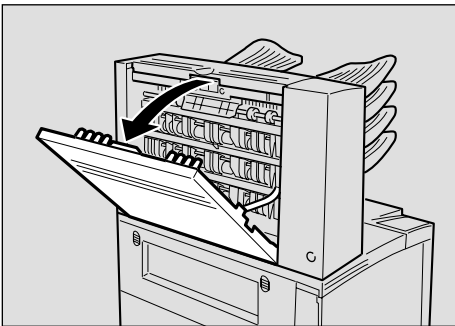

ZCEY460J

2 Remove the misfed paper.

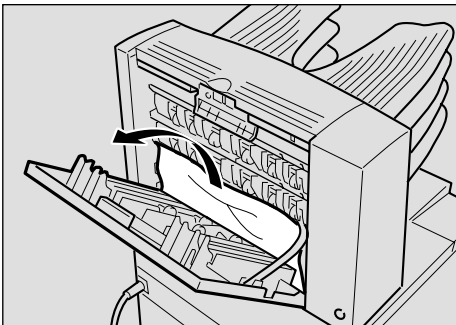

ZCEY470J

3 Close the cover of the Mailbox.

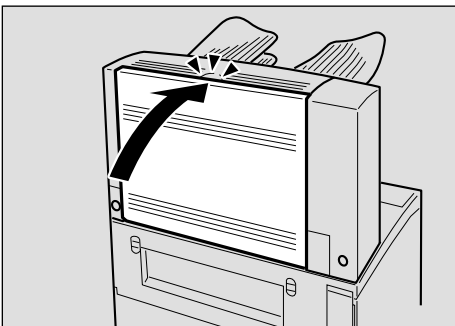

ZCEY480J

When "Remove Misfeed Upper Tray Unit" Appears

⚠ Important

- ❑ Forcefully removing misfed paper may cause paper to tear and leave scraps of paper in the 1-bin Shift Sort Tray. This might cause a misfeed and damage the printer.

1 Open the upper tray cover.

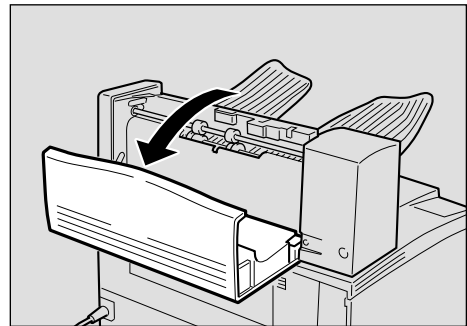

ZCEY490J

2 Remove the misfed paper.

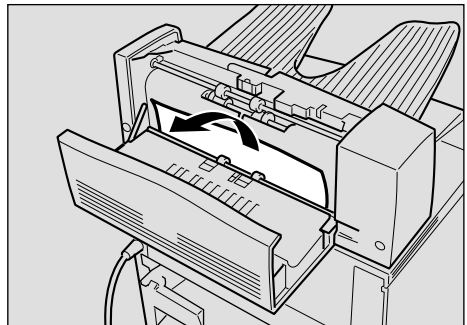

ZCEY500J

3 Close the upper tray cover.

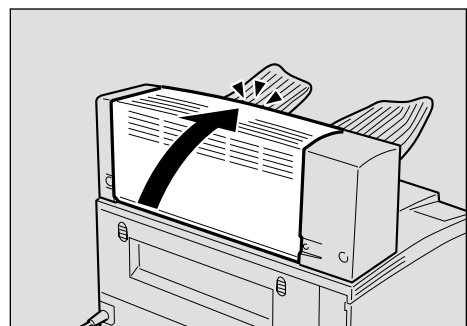

ZCEY510J

Replacing the Toner Cartridge

⚠ WARNING:

- **Do not incinerate spilled toner or used toner. Toner dust might ignite when exposed to an open flame.**
- **Disposal can take place at our authorized dealer or at appropriate collection sites.**
- **If you dispose the used toner cartridges yourself, dispose of them according to your local regulations.**

⚠ CAUTION:

- *The inside of the machine could be very hot. Do not touch the parts with a label indicating "⚠" (means hot surface). Touching "⚠" (means hot surface) could result in a burn.*
- *Do not eat or swallow toner.*
- *Keep toner (used or unused) and toner cartridges out of reach of children.*
- *Our products are engineered to meet the highest standards of quality and functionality. When purchasing expendable supplies, we recommend using only those specified by an authorized dealer.*

When "Replace Toner Cartridge" appears on the panel display, the toner is almost empty. Prepare a new toner cartridge. If the image density gets too light, replace the toner cartridge with a new one.

⚠ Important

- ❑ Do not expose the toner cartridge to light for a long time. Do not leave the front cover open for a long time. If the toner cartridge is exposed to a light for a long time, the toner cartridge might be damaged and print quality might be reduced.

📝 Note

- ❑ Do not stand or place the toner cartridge upside-down.
- ❑ The actual number of printed pages you get from a particular toner cartridge depends on the type and size of paper you are using, the contents of the print images, and printing environment conditions. All this means that a toner cartridge might require replacement sooner than the normal life described on p.164 "Consumables".

1 Open the front cover by pushing the front cover release button.

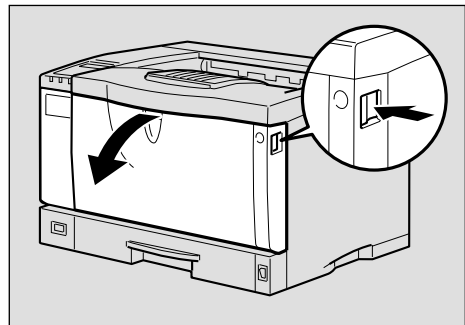

ZCEH120J

- 2** Be sure to put the toner cartridge on a stable, flat surface.

Note

- Do not put the toner cartridge on an unstable or tilted surface.

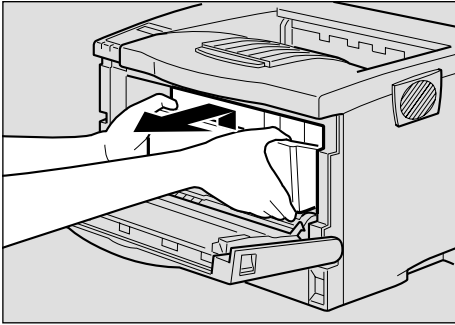

ZGDT110J

- 3** Wipe around the metallic registration roller by turning with a soft damp cloth.

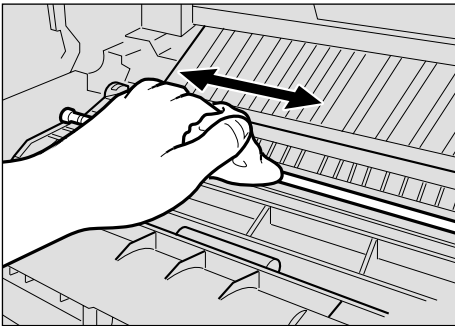

ZCEX461J

Important

- Do not use chemical cleaner or organic solvent such as thinner or benzene.

- 4** Take the new toner cartridge from the box.

- 5** Place the toner cartridge on a flat surface. Pull out the tape inside the unit horizontally while holding the cartridge with one hand as shown in the illustration.

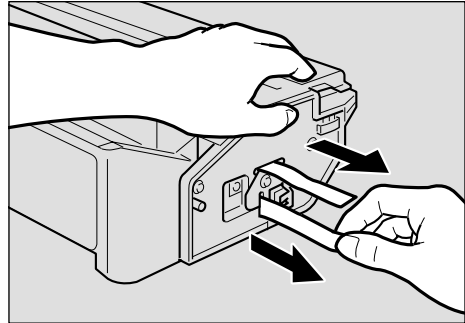

ZCET151J

Note

- Be sure to remove the tape completely before installing the new toner cartridge, otherwise the printer might be damaged.
- Keep the toner cartridge horizontal when pulling out the toner seal. Pulling out the toner seal with the cartridge upright or tilted can cause printer failure.
- Be careful not to get toner dust on your hands or clothes.
- Do not shake or shock the toner cartridge after pulling out the toner seal to avoid dirt on paper surfaces, toner spillage, or printer failure.

- 6** Holding the grips of the cartridge, insert it into the printer until it stops.

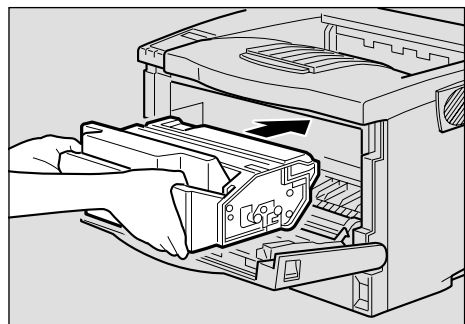

ZGDT120J

- 7** Push down the toner cartridge to settle it in appropriate position.

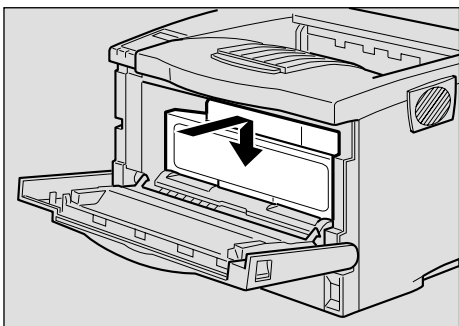

ZGDT140J

- 8** Close the front cover.

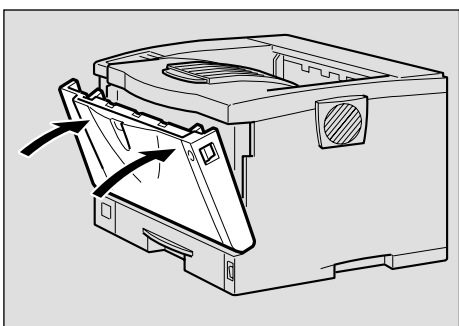

ZGDH130J

Important

- Do not close the front cover with force. If you cannot close the cover easily, pull out the toner cartridge from the printer and insert it again. After that, close the front cover again.

Cleaning and Adjusting the Printer

Cleaning the Friction Pad

If the friction pad is dirty, a multi-feed or a misfeed might occur. In this case, clean the pad as follows:

- 1 Lift the paper tray slightly then pull it out until it stops, and while lifting the front side of the tray, pull it out of the printer.

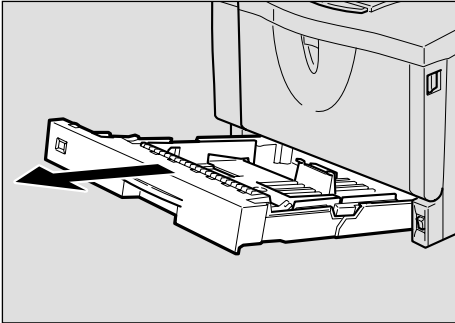

ZCEY140J

- 2 Place the tray on a flat surface. When there is paper in the tray, remove paper.

- 3 Wipe the brown part of the friction pad with a soft damp cloth. After that, wipe it with a dry cloth to remove the water.

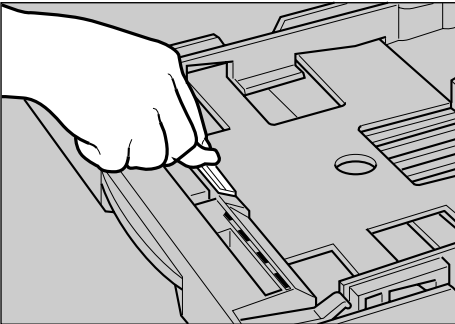

TS3Y250E

Important

- ❑ Do not use chemical cleaner or organic solvent such as thinner or benzene.

- 4 Load paper into the paper tray with the print side up. Carefully slide the paper tray into the printer until it stops.

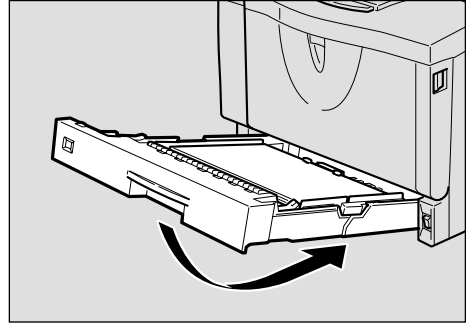

ZCEY150J

Important

- ❑ Do not slide the paper tray in with force. If you do, the front and side guides might move.

Note

- ❑ If misfeeds or multi-feeds of paper occur after cleaning the friction pad, contact your sales or service representative.
- ❑ Follow the same procedure to clean the friction pad of the optional Paper Feed Unit and the Envelope Feeder Unit.

Cleaning the Paper Feed Roller

If the paper feed roller is dirty, a mis-feed might occur. In this case, clean the roller as follows:

⚠ CAUTION:

- When lifting the printer, use the grips on both sides of the printer, otherwise the printer might fall and cause personal injury.
- When you move the printer, unplug the power cord from the wall outlet to avoid a fire or an electric shock.
- When you pull out the plug from the socket, grip the plug to avoid damaging the cord and causing a fire or an electric shock.

⚠ Important

- ❑ The following are examples of cleaning the paper feed roller on the paper tray.
- ❑ You can clean the paper feed roller on the optional Paper Feed Unit by following the procedures below. The paper feed roller on the optional Paper Feed Unit differs from the one on the paper tray. Confirm the type of paper feed roller you are installing.

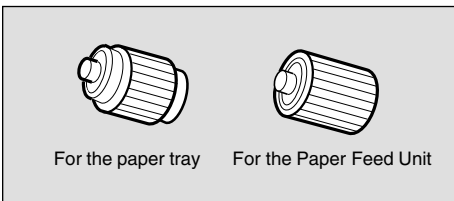

ZCEM200E

- 1 Turn off the power switch.
- 2 Pull out the plug from the socket. Remove all the cables from the printer.

- 3 Lift the paper tray slightly then pull it out until it stops, and while lifting the front side of the tray, pull it out of the printer.

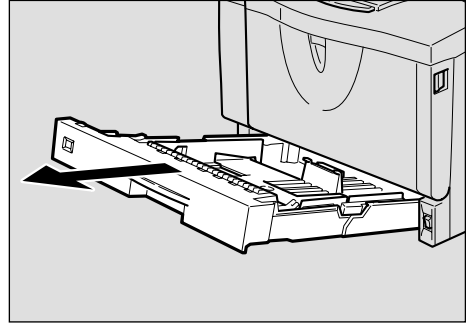

ZCEY140J

- 4 Move the printer to the edge of a stable table or desk.

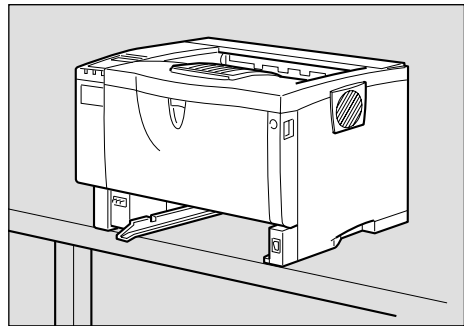

ZGDM110J

⚠ Important

- ❑ Do not put the printer on an unstable or tilted surface.
- ❑ If the printer is equipped with the optional Paper Feed Unit, do not move the printer and unit together as they are not securely attached.
- ❑ When lifting the printer, confirm that the optional Paper Feed Unit is not attached to the printer.

- 5** Slide the green lock lever to the left (①), so that the paper feed roller can be released (②).

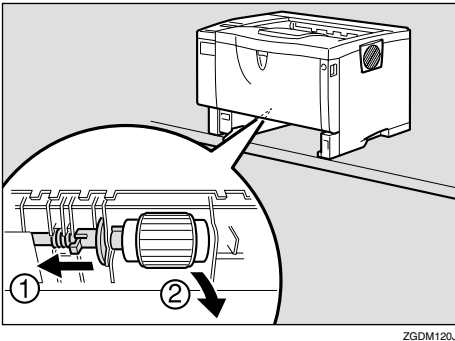

ZGDM120J

- 6** Wipe the rubber part of the roller with a soft damp cloth. After that, wipe it with a dry cloth to remove the water.

Important

- Do not use chemical cleaner or organic solvent such as thinner or benzene.

- 7** While sliding the green lock lever to the left (①), set the paper feed roller to its original position (②). After that, return the green lock lever to its original position (③).

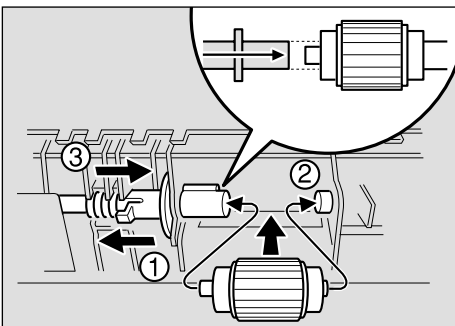

ZCEM130J

Note

- Confirm that the green lock lever secures the roller correctly by confirming that the roller rotates smoothly.

- 8** Move the printer to the place where it was placed. Carefully slide the paper tray into the printer until it stops.

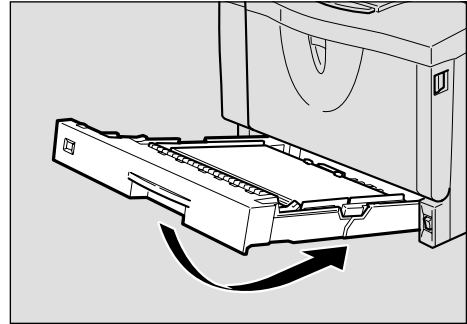

ZCEY150J

Important

- Do not slide the paper tray in with force. If you do, the front and side guides might move.

- 9** Insert the plug of the power cord into the wall socket securely. Connect all the cables that were removed in step 2.

- 10** Turn on the power switch.

Note

- Follow the same procedure to clean the paper feed roller of the optional Paper Feed Unit.

Cleaning the Registration Roller

If the registration roller is dirty, a mis-feed might occur. In this case, clean the roller as follows:

⚠ WARNING:

- **Be sure to turn off the power switch and wait for about 30 minutes before cleaning the registration roller. Not waiting for the printer to cool down can result in a burn.**

⚠ CAUTION:

- *The inside of the machine could be very hot. Do not touch the parts with a label indicating "⚠" (means hot surface). Touching "⚠" (means hot surface) could result in a burn.*

- 1** Turn off the power switch.
- 2** Open the front cover by pushing the front cover release button.

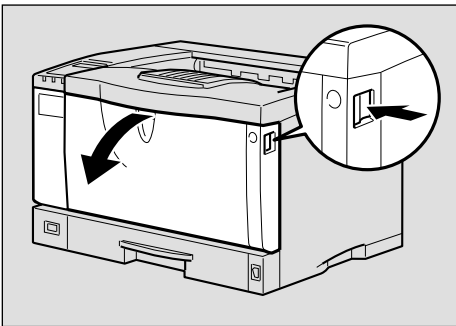

ZCEH120J

- 3** Pull the toner cartridge out of the printer by holding the grips of the cartridge.

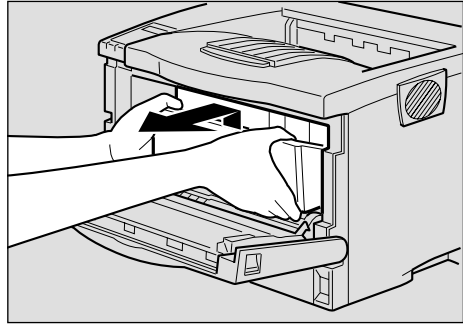

ZGDT110J

Note

- Do not hold the toner cartridge upside down or stand it vertically.
- Do not put the toner cartridge on an unstable or tilted surface.

- 4** Wipe around the metallic registration roller by turning with a soft damp cloth.

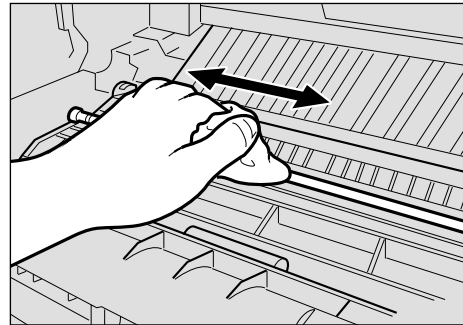

ZCEX461J

⚠ Important

- Do not use chemical cleaner or organic solvent such as thinner or benzene.

- 5** Holding the grips of the toner cartridge, insert it into the printer until it stops.

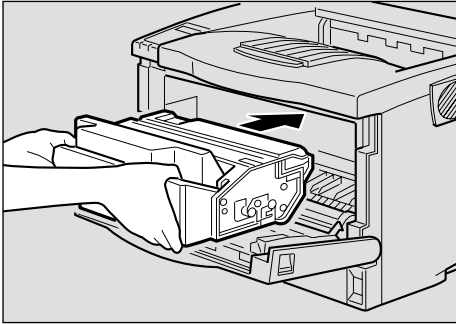

ZGDT120J

- 6** Push down the toner cartridge to settle it in appropriate position.

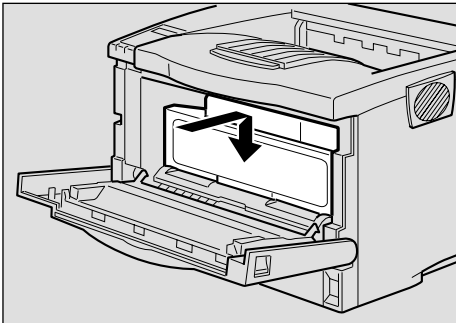

ZGDT140J

- 7** Close the front cover.

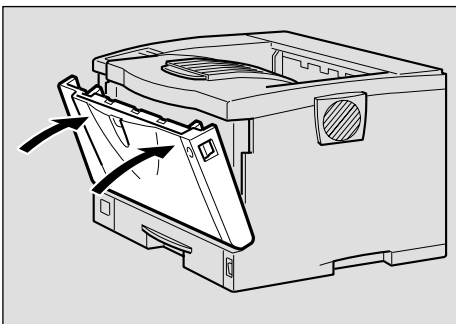

ZGDH130J

Important

- Carefully close the front cover. If you cannot close the cover easily, pull the toner cartridge out of the printer and insert it again. After that, close the front cover again.

- 8** Turn on the power switch.

Adjusting the Image Density

You can adjust the image density when the print side of the page is a shaded or print image is too light.

Important

- Extreme settings may create print-outs that appear dirty.
- Image density settings should be made from the application or the printer driver whenever possible.

- 1** Press **[Menu]**.

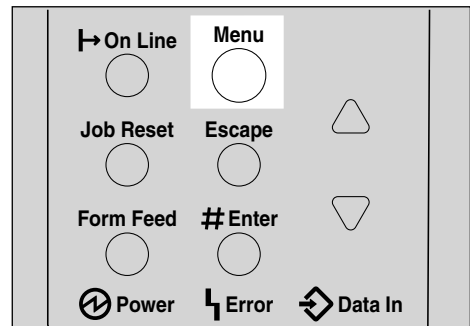

ZDDS020N

"Menu" appears on the panel display.

- 2** Press **[▲]** or **[▼]** to display the "Maintenance" menu, and then press **[Enter #]**.

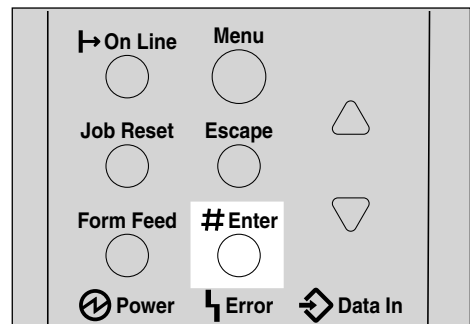

ZDDS021N

The following message appears on the panel display.

```
Maintenance:
Image Density
```

3 Press **[Enter #]**.



4 Press **[▲]** or **[▼]** to set the image density value.

Note

- To maintain a darker image under high volume printing conditions, we highly recommended that you select 3 from the control panel.
- You can adjust the image density in seven steps from -3 to +3. Increasing the value makes the printouts darker and decreasing the value makes the printouts lighter.

5

5 Press **[Enter #]**.

6 Press **[On Line]**.

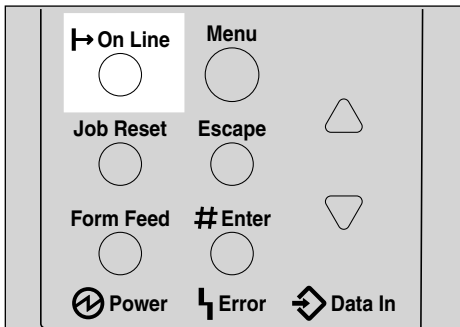

ZDDS022N

"Ready" appears on the panel display.

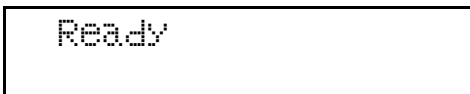

Adjusting the Registration of the Trays

You can adjust the registration of each tray. The vertical adjustment is used for all trays. Normally, you need not update the registration. But when the optional Paper Feed Unit or the Duplex Unit is installed, updating the registration is useful in some case.

The following procedure describes how to adjust Tray 1. You can use the same procedure to adjust the other tray as well.

1 Press **[Menu]**.

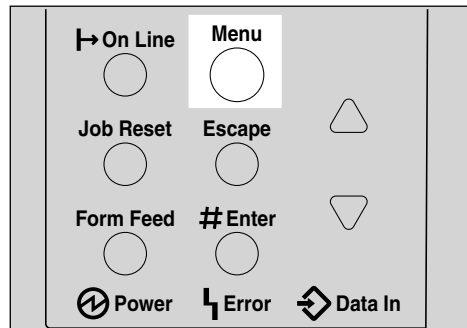

ZDDS020N

"Menu" appears on the panel display.

- 2 Press **[▲]** or **[▼]** to display the "Maintenance" menu, and then press **[Enter #]**.

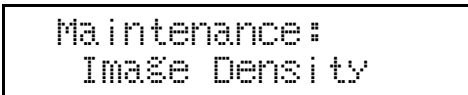
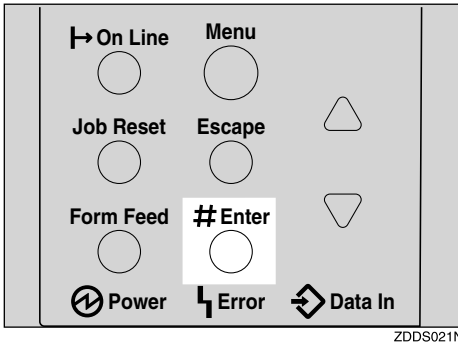

- 3 Press **[▲]** or **[▼]** to display "Registration", and then press **[Enter #]**.

The following message appears on the panel display.

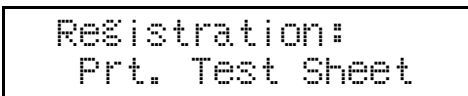

- 4 Print the test sheet to preview the settings you have made.

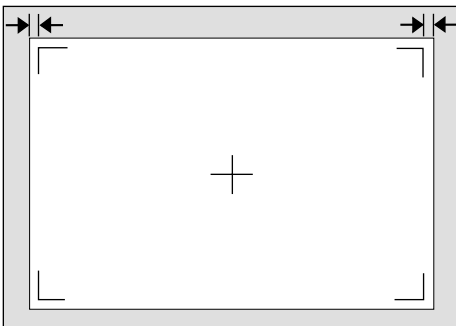

- 1 After confirming that "Prt. Test Sheet" is on the panel display, press **[Enter #]**.

The following message appears on the panel display.



- 2 Press **[▲]** or **[▼]** to display the tray you want to adjust, and then press **[Enter #]** to print the test sheet. Wait for a few seconds.

The following message appears on the panel display.

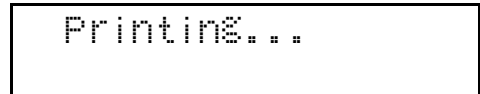

- 5 Adjust the registration by confirming the position of the printed image of the test sheet.

The following is an example of adjusting the margin on the test sheet equally.

- 1 Press **[▲]** or **[▼]** to display "Adjustment", and then press **[Enter #]**.

The following message appears on the panel display.

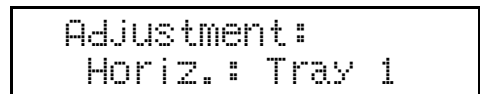

- 2 Press **[▲]** or **[▼]** to display the tray you want to adjust, and then press **[Enter #]**.

The following message appears on the panel display.

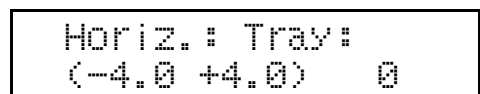

- 3 Press **[▲]** or **[▼]** to set the digit of the registration value (mm).

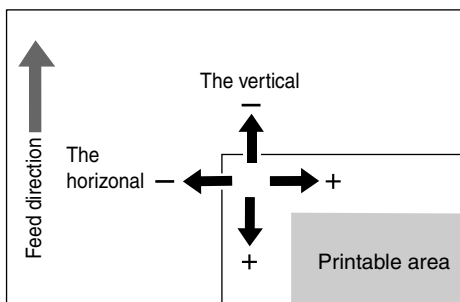

TS3X001N

Note

- Increase the value to shift the print area to the positive direction, and decrease to shift to the negative direction.
- Pressing **[▲]** or **[▼]** makes the value increase or decrease by 0.5 mm step.

- 4 Press **[OK]**.

- 6 Print the test sheet to check the settings you have made.

- 7 Repeat steps 3 and 4 to adjust the registration if necessary.

- 8 Press **[On Line]**.

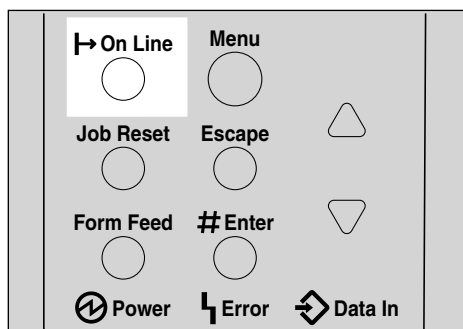

ZDS022N

“Ready” appears on the panel display.



6. Making Printer Settings with the Control Panel

Menu Chart

This section describes how to change the default settings of the printer and provides information on the parameters included in each menu. Some items in the menu appear only when certain options are installed.

Category	Function menu
Sample Print *1 ⇒ p.51	Select Action / Error File(s)
Locked Print *1 ⇒ p.56	Select Action / Error File(s)
Paper Input⇒ p.106	Bypass Size
	Tray Paper Size
	Paper Type
	Tray Locking
	Tray Priority
List/Test Print⇒ p.110	Config. Page
	Menu List
	PS Font List
	PCL Config.Page
	Hex Dump
Maintenance⇒ p.114	Image Density
	Registration
	Curl Prevention
	ROM Update *2
	HDD Format
	WL.LAN Signal *3
	WL.LAN Defaults
	Key Repeat
	Menu Protect *4
	Series Prnt.Job *4
Ppr.Size Error *4	

Category	Function menu
System⇒ p.124	MisfeedRecovery
	Prt. Err Report
	Auto Continue
	Memory Overflow
	Sub Paper Size
	Page Size
	Edge-Edge Print
	Duplex *5
	Output Tray
	Job Separation
	Energy Saver
	Memory Usage
	Unit Of Measure
	Edge Smoothing
	Resolution
Toner Saving	
Spool Printing	
Host Interface⇒ p.130	I/O Buffer
	I/O Timeout
	Network Setup
	IEEE 1394 Setup *6
	IEEE 802.11b *7
	USB Setting *4
PCL Menu⇒ p.137	Orientation
	Form Lines
	Font Source
	Font Number
	Point Size
	Font Pitch
	Symbol Set
	Ext. A4 Width
Language⇒ p.141	

*1 The “Sample Print” menu and the “Locked Print” menu appear only when the optional Hard Disk Drive is installed.

*2 ROM Update is not currently used.

-
- *3 The "WLAN Signal" menu appears only when "IEEE 802.11b" is selected in "LAN Type" in the Host Interface menu.
 - *4 While the printer is **On Line**, press **[Enter #]**, and then press **[Escape]**. Finally, press **[Menu]**. You can access the "Menu Protect", "Series Prnt.Job", "Ppr.Size Error", and "USB Setting" on the panel display.
 - *5 The "Duplex" menu appears only when the optional Duplex Unit is installed.
 - *6 The "IEEE 1394 Setup" menu appears only when the optional 1394 Interface Unit is installed.
 - *7 The "IEEE 802.11b Setup" menu appears only when the optional 802.11b Interface Unit is installed.

Accessing the Main Menu

Press **[Menu]**, and "Menu" appears on the panel display.

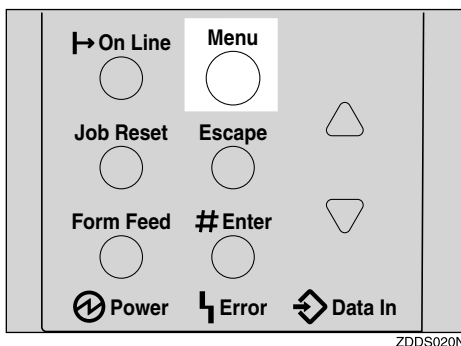

This menu shows the following nine items which can be displayed one by one pressing **[▲]** or **[▼]**.

- Sample Print
- Locked Print
- Paper Input
- List/Test Print
- Maintenance
- System
- Host Interface
- PCL Menu
- Language

Note

- "Sample Print" and "Locked Print" appear only when the optional Hard Disk Drive is installed.
- [▼]**: Press to go to the next page.
- [▲]**: Press to go back to the previous page.

- ❑ After making the printer settings, be sure to return to the previous menu by pressing **[Escape]**.

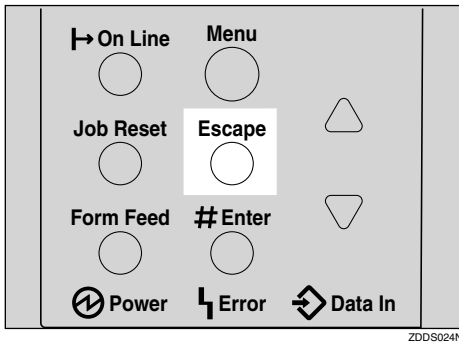

- ❑ After making the printer settings, press **[On Line]** to return to the “Ready” condition.

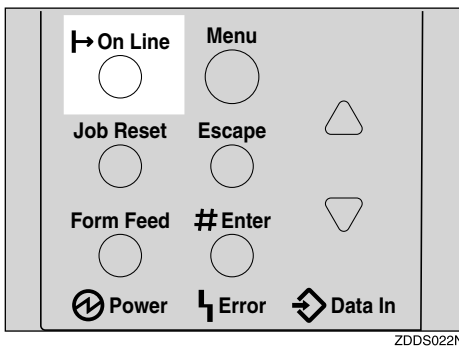

- ❑ The revised settings are not canceled even if the power switch is turned off.

Paper Input Menu

There are five menu items in the “Paper Input” menu.



- Bypass size
- Tray Paper Size
- Paper type
- Tray Locking
- Tray Priority

Reference

For more information about loading paper in the tray, see p.37 “Loading Paper and Other Media”.

Paper Input Parameters

Menu	Description
Bypass Size	The paper size for the Bypass Tray. For more information about paper sizes that can be set in the Bypass Tray, see p.25 “Paper and Other Media Supported by This Printer”.
Tray Paper Size	The paper size for each tray. When you select sizes that are not indicated on the paper size dial of Tray 1, Tray 2 or Tray 3, you should set the dial to “✱” and then select the paper size here. ❖ Tray 1 For more information about paper sizes that can be set in the Tray 1, see p.25 “Paper and Other Media Supported by This Printer”. ❖ Tray 2 For more information about paper sizes that can be set in the Tray 2, see p.25 “Paper and Other Media Supported by This Printer”. ❖ Tray 3 For more information about paper sizes that can be set in the Tray 3, see p.25 “Paper and Other Media Supported by This Printer”.  Note <input type="checkbox"/> Only the installed trays appear on the panel display.

Menu	Description
Paper Type	<p>If you use different kinds of paper, you set the paper type for Tray 1, Tray 2, Tray 3 or Bypass Tray.</p> <p>❖ Tray 1, Tray 2, Tray 3 Plain Paper, Recycled Paper, Special Paper, Color Paper, Letterhead, Preprinted, Prepunched, Bond paper, Cardstock</p> <p>❖ Bypass Tray Plain Paper, Recycled Paper, Special Paper, Color Paper, Letterhead, Preprinted, Prepunched, Labels, Bond paper, Cardstock, Transparency, Thick Paper</p> <p> Note</p> <ul style="list-style-type: none"> <input type="checkbox"/> Default : Plain Paper <input type="checkbox"/> Only the installed trays appear on the panel display.
Tray Locking	<p>If you use different kinds of paper, you can lock a tray to prevent printing on wrong paper such as letterhead or colored paper. When "Auto Select" is selected in the Paper Source selections from the printer driver, the locked tray will not be used.</p> <p>Tray 1, Tray 2, Tray 3, Bypass Tray</p> <p> Note</p> <ul style="list-style-type: none"> <input type="checkbox"/> Only the installed trays appear on the panel display. <input type="checkbox"/> You can lock multiple trays. <input type="checkbox"/> If you want to use the locked tray, you must select the tray from the printer driver. <input type="checkbox"/> When a locked tray is selected from the printer driver, the printer does not search for another tray.
Tray Priority	<p>You can set priority tray for paper feed when "Auto tray Selected" is selected in the Paper Source selections from the printer driver. When printing from DOS, the tray selected here is used when no tray is selected for a print job.</p> <p>Tray 1, Tray 2, Tray 3, Bypass Tray</p> <p> Note</p> <ul style="list-style-type: none"> <input type="checkbox"/> Default : Tray 1 <input type="checkbox"/> Only the installed trays appear on the panel display. <input type="checkbox"/> It is recommended that you load paper of the size and direction you most frequently use in the tray selected with "Tray Priority".

Changing the Paper Input Menu

- 1 Press **[Menu]**.

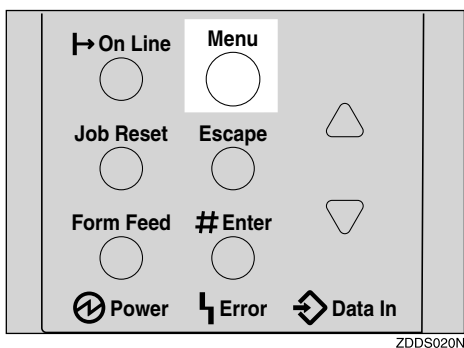

“Menu” appears on the panel display.

- 2 Press **[▲]** or **[▼]** to display the “Paper Input” menu.

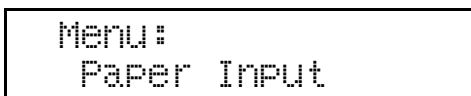

- 3 Press **[Enter #]**.

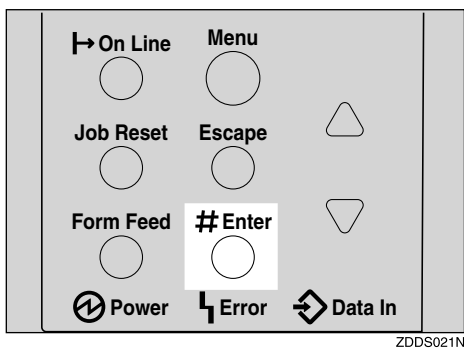

- 4 Press **[▲]** or **[▼]** to display “Tray Priority”.



- 5 Press **[Enter #]**.

The following message appears on the panel display.

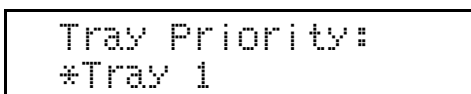

6 Press **[▲]** or **[▼]** to select the tray type you want to use.

7 Press **[Enter #]**. Wait for a few seconds.

8 Press **[On Line]**.

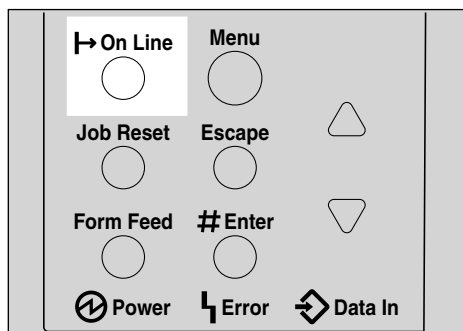

“Ready” appears on the panel display.

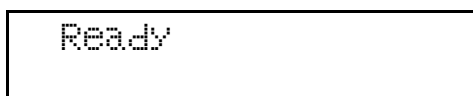

List/Test Print Menu

There are five menu items in the “List/Test Print” menu.

- Config. Page
- Menu List
- PS Font List
- PCL Config. Page
- Hex Dump

List/Test Print Parameters

Menu	Description
Config. Page	You can print the current configuration of the printer. See p.110 “Printing a Configuration Page”.
Menu List	You can print the Menu List which shows the function menus of this printer.
PS Font List	You can print the current configuration and installed PS font list of PostScript.
PCL Config. Page	You can print the current configuration of PCL.
Hex Dump	You can print the data sent by the computer using the Hex Dump mode.

6

Printing a Configuration Page

Reference

For more information, see p.112 “Interpreting the Configuration Page”.

1 Press **[Menu]**.

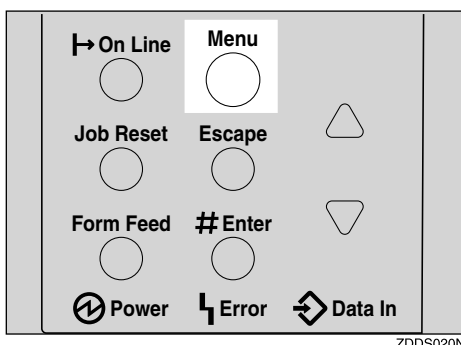

“Menu” appears on the panel display.

- 2** Press [▼] or [▲] to display the “List/Test Print” menu.

```
Menu:
List/Test Print
```

- 3** Press [Enter #].

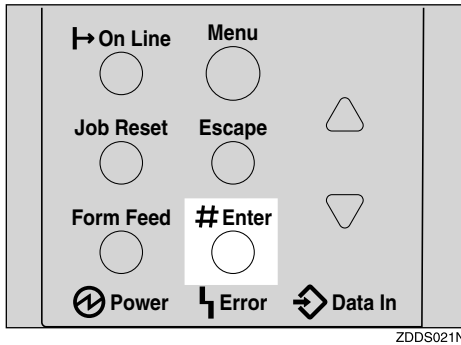

The following message appears on the panel display.

```
List/Test Print:
Config. Page
```

- 4** Press [Enter #].

The following message appears on the panel display.

```
Printing...
```

The configuration page will be printed in a short time.

Important

- If you cannot print a configuration page correctly, check for an error message on the panel display. For more information about error messages, see p.61 “Error & Status Messages on the Control Panel”.

5 Press **[On Line]**.

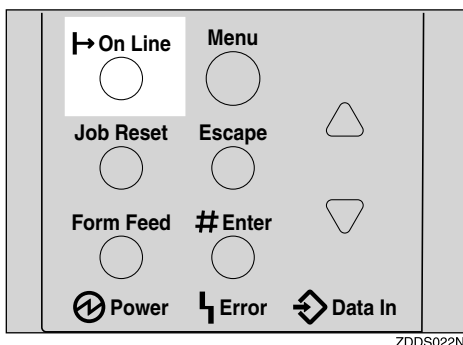

“Ready” appears on the panel display.



Interpreting the Configuration Page

6

System Reference

- ❖ **Printer ID**
Shows the serial number assigned to the board by its manufacturer.
- ❖ **Firmware Version**
 - Firmware
Shows the version number of the printer firmware.
 - Engine
Shows the version number of the printer engine.
 - NCS
Shows the version number of the Network interface.
- ❖ **Pages Printed**
Shows the total number of pages printed by the printer to date.
- ❖ **Total Memory**
Shows the total amount of memory (SDRAM) installed on the printer.
- ❖ **Printer Language**
Shows the version number of the printer driver language.
- ❖ **Controller Option**
The item(s) appears when the controller option(s) is installed.
- ❖ **Options**
Shows the optional trays that you installed.

Paper Input

Shows the settings made under the “Paper Input” menu.

 **Reference**

For more information, see p.106 “Paper Input Menu”.

Maintenance

Shows the settings made under the “Maintenance” menu.

 **Reference**

For more information, see p.114 “Maintenance Menu”.

System

Shows the settings made under the “System” menu.

 **Reference**

For more information, see p.124 “System Menu”.

PCL Menu

Shows the settings you made under the “PCL Menu”.

 **Reference**

For more information, see p.137 “PCL Menu”.

Host Interface

Shows the settings you made under the “Host Interface” menu.

When DHCP is active on the network, the actual IP Address, Subnet Mask and Gateway Address appear in parentheses on the configuration page.

 **Reference**

For more information about “Host Interface” menu, see p.130 “Host Interface Menu”.

Interface Information

Shows the interface information.

Error Log

Shows the log of printer errors.

Maintenance Menu







There are 11 menu items in the “Maintenance” menu.





- Image Density
- Registration
- ROM Update
- Curl Prevention
- HDD Format
- WL.LAN Signal
- WL.LAN Defaults
- Key Repeat
- Menu Protect
- Series Prnt.Job
- Ppr.Size Error

 **Note**

- ❑ “HDD Format” appears only when the optional Hard Disk Drive is installed. For more information, see “*Hard Disk Drive Type 2600*” in the Setup Guide.

Maintenance Menu Parameters

Menu	Description
Image Density	<p>You can select the print image density. -3 to 3</p> <p> Reference For more information, see p.97 "Adjusting the Image Density".</p>
Registration	<p>◆ Prt. Test Sheet You can print the registration test sheet. Tray 1, Tray 2, Tray 3, Bypass Tray, Duplex backside</p> <p> Note</p> <ul style="list-style-type: none"> <input type="checkbox"/> Default : Tray 1 <input type="checkbox"/> Only the installed trays appear on the panel display. <p>◆ Adjustment You can select the start position for printing on a page. Horiz.: Tray 1, Horiz.: Tray 2, Horiz.: Tray 3, Horiz.: Bypass, Horiz.: Dup.Back, Vert.: All Trays, Vert.: Dup.Back -4 to 4</p> <p> Note</p> <ul style="list-style-type: none"> <input type="checkbox"/> Default : Horiz.: Tray 1 <input type="checkbox"/> The registration value is not a default. <input type="checkbox"/> Only the installed trays appear on the panel display. <p> Reference For more information, see p.98 "Adjusting the Registration of the Trays".</p>
Curl Prevention	<p>You can control the fuser temperature to prevent paper from curling.</p> <p> Note</p> <ul style="list-style-type: none"> <input type="checkbox"/> Default: Off <input type="checkbox"/> Use this mode only when paper misfeed occurs frequently during duplex printing.
ROM Update	<p>This menu is not currently used.</p>
HDD Format	<p>After installing the Hard Disk Drive, format it.</p> <p> Note</p> <ul style="list-style-type: none"> <input type="checkbox"/> This menu appears only when the optional Hard Disk Drive is installed. <p> Reference For more information about formatting the Hard Disk Drive, see p.119 "Formatting Hard Disk Drive Type 2600".</p>

Menu	Description
WL. LAN Signal	<p>You can check the signal strength when using the wireless LAN.</p> <p> Reference</p> <p>For more information about displaying the signal strength, see p.120 "Displaying the Signal Strength".</p>
WL. LAN Defaults	<p>You can reset the wireless LAN settings to the default.</p>
Key Repeat	<p>You can scroll through the menu by holding this key down.</p> <p> Note</p> <p><input type="checkbox"/> Default: On</p>
Menu Protect ^{*1}	<p>This procedure lets you protect menu settings against accidental changes. It makes it impossible to change the menu settings you make with the normal procedure unless you perform the required key operation. In a network environment, protecting settings restricts who can change menu settings to network administrators.</p> <ul style="list-style-type: none"> • Level 1 • Level 2 • Off
Series Prnt.Job ^{*1}	<p>You can print series of print jobs without time intervals between them when jobs are sent from the same computer, PDL, and interface.</p> <p> Note</p> <p><input type="checkbox"/> Default: On</p> <p><input type="checkbox"/> When the Job Reset key is pressed, all jobs sent to the machine will be canceled.</p>
Ppr.Size Error ^{*1}	<p>You can select whether to have an error report printed when the paper size setting for the tray differs from the actual size of the paper in the tray. You can also select whether to have an error message displayed when feeding paper from the tray.</p> <p> Note</p> <p><input type="checkbox"/> Default: Do not detect</p> <p><input type="checkbox"/> When it is "Detect", it prints with the paper size that was set when the error message appeared.</p>

^{*1} While the printer is Online, press **[Enter #]**, and then press **[Escape]**. Finally, press **[Menu]**. You can access the "Menu Protect", "Series Prnt.Job" and "Ppr. Size Error" menu on the panel display.

Changing the Maintenance Menu

Protecting the menus

- 1** Check if the On Line indicator is on. If not, press **[On Line]** to enter the "Ready" condition.
- 2** Press **[Enter #]**, then **[Escape]**, and then **[Menu]**.

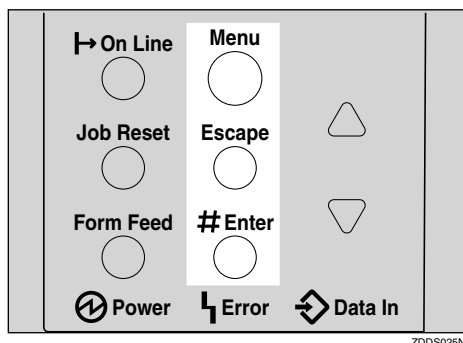

"Menu" appears on the panel display.

- 3** Press **[▲]** or **[▼]** to display the "Maintenance" menu, and then press **[Enter #]**.

The following message appears on the panel display.

```
Maintenance:
  Image Density
```

- 4** Press **[▲]** or **[▼]** to display "Menu Protect".

```
Maintenance:
  Menu Protect
```

- 5** Press **[Enter #]**.

The following message appears on the panel display.

```
Menu Protect:
  *Off
```

- 6** Press **[▲]** or **[▼]** to select the levels desired, and then press **[Enter #]**. Wait for a few seconds.

7 Press **[On Line]**.

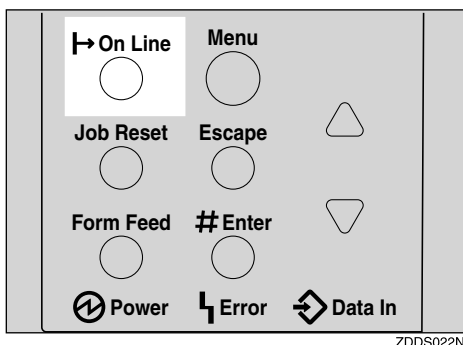

"Ready" appears on the panel display.



Canceling the protection

6

1 Check if the On Line indicator is on. If not, press **[On Line]** to enter the "Ready" condition.

2 Press **[Enter #]**, then **[Escape]**, and then **[Menu]**.

"Menu" appears on the panel display.

3 Press **[▲]** or **[▼]** to display "Maintenance" menu, and then press **[Enter #]**.

The following message appears on the panel display.

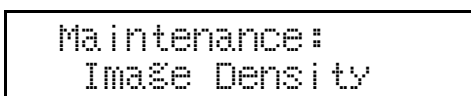

4 Press **[▲]** or **[▼]** to display "Menu Protect", and then press **[Enter #]**.

5 Press **[▲]** or **[▼]** to display "Off", and then press **[Enter #]**. Wait for a few seconds.

6 Press **[On Line]**.

"Ready" appears on the panel display.

Formatting Hard Disk Drive Type 2600

If you are formatting the Hard Disk Drive for the first time, follow the procedures below using the control panel.

1 Press **[Menu]**.

“Menu” appears on the panel display.

2 Press **[▲]** or **[▼]** to display “Maintenance” menu.

```
Menu:
Maintenance
```

3 Press **[Enter #]**.

The following message appears on the panel display.

```
Maintenance:
Image Density
```

4 Press **[▲]** or **[▼]** to display “HDD Format”.

```
Maintenance:
HDD Format
```

5 Press **[Enter #]**.

The following message appears on the panel display.

```
HDD Format:
Press# to Start
```

6 Press **[Enter #]**.

Important

- Do not turn off the printer while formatting the Hard Disk Drive. Turning off the printer while formatting the Hard Disk Drive can damage the Hard Disk Drive.

If you successfully format the Hard Disk Drive, the following message appears on the panel display.

```
Completed
Restart Printer
```

7 Turn off the power switch, and then turn it back on.

Displaying the Signal Strength

If you need to check the IEEE 802.11b (Wireless LAN) signal, select "WL.LAN Signal" in the "Maintenance" menu.

1 Press **[Menu]**.

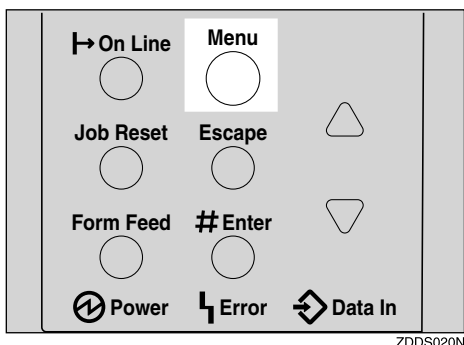

"Menu" appears on the panel display.

2 Press **[▼]** or **[▲]** to display the "Maintenance" menu.

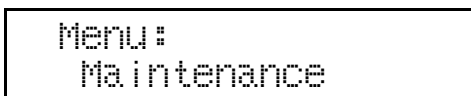

3 Press **[Enter #]**.

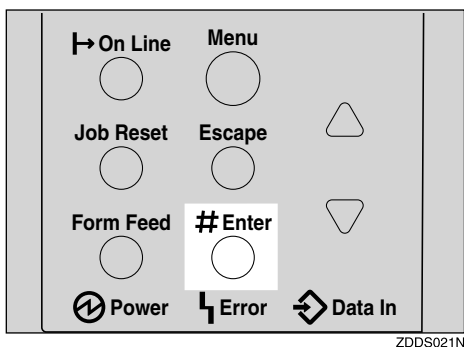

The following message appears on the panel display.

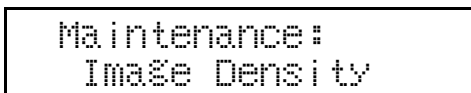

4 Press **[▼]** or **[▲]** to display "WL.LAN Signal".

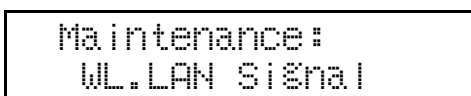

5 Press **[Enter #]**.

One of the following messages appears on the panel display.

```
WL.LAN Signal
Good          100%
```

```
WL.LAN Signal
Fair          50%
```

```
WL.LAN Signal
Poor          30%
```

```
WL.LAN Signal
Unavailable   18%
```

 **Note**

- If "WL.LAN Signal" is not displayed, "IEEE 802.11b" has not been selected for "LAN Type" in "Network Setup" of the Host Interface menu. Select "IEEE 802.11b" for "LAN Type", and then check the "WL.LAN Signal" in the Maintenance menu again.
- If "Ad hoc" in "Comm. Mode" of "IEEE 802.11b" in the Host Interface menu is selected, you cannot check the signal. Select "Infrastructure" and then check it again.
- Every time you press **[Enter #]**, the signal is updated.
- The signal is indicated as "Good" if the signal strength is 76-100%, "Fair" if the strength is 41-75%, "Poor" if the strength is 21-40%, and "Unavailable" if the strength is 0-20%. If the signal is unstable or unavailable, remove obstacles or move the printer to a place where the signal can be received.
- Using wireless devices or microwave sources near the printer might affect the signal.

6 Press **[Escape]**.

7 Press **[On Line]**.

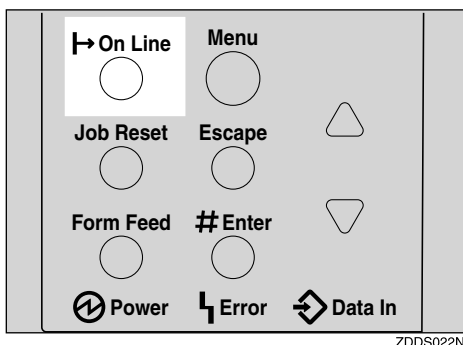

“Ready” appears on the panel display.



Resetting the IEEE 802.11b (Wireless LAN) Settings

6

If you need to reset the wireless LAN setting, select "WL.LAN Defaults" in the Maintenance menu.

 **Note**

- The four items that can be reset in "IEEE 802.11b" of the Host Interface menu are "Comm.Mode", "Channel", "Trans. Speed", and "WEP Settings". Other items that can be reset are the SSID settings, the WEP key settings, and the wireless LAN settings that can be made with telnet.

1 Press **[Menu]**.

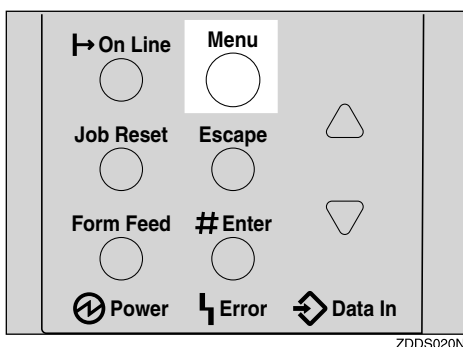

“Menu” appears on the panel display.

2 Press **[▼]** or **[▲]** to display the “Maintenance” menu.

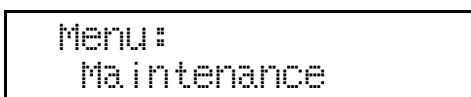

3 Press **[Enter #]**.

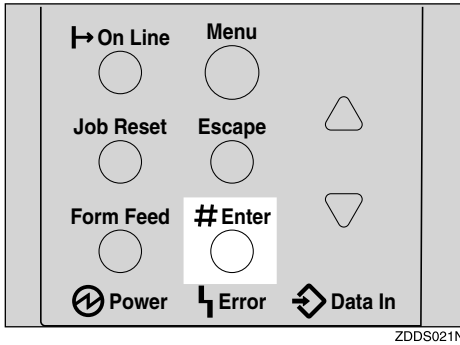

The following message appears on the panel display.

```
Maintenance:
Image Density
```

4 Press **[▼]** or **[▲]** to display "WL.LAN Defaults".

```
Maintenance:
WL.LAN Defaults
```

5 Press **[Enter #]**.

```
WL.LAN Defaults
Reset->Defaults?
```

6 Press **[Enter #]**.

The following message appears on the panel display.

```
Defaults reset
```

The wireless LAN setting value is reset.

"Ready" appears on the panel display.

```
Ready
```



System Menu







There are 17 menu items in the “System” menu.





- MisfeedRecovery
- Prt. Err Report
- Auto Continue
- Memory Overflow
- Sub Paper Size
- Page Size
- Edge-Edge Print
- Duplex
- Output Tray
- Job Separation
- Energy Saver
- Memory Usage
- Unit Of Measure
- Edge Smoothing
- Resolution
- Toner Saving
- Spool Printing





6

System Parameters

Menu	Description
MisfeedRecovery	<p>You can select whether Misfeed Recovery is enabled. When it is on, printing restarts after the misfed paper has been cleared.</p> <ul style="list-style-type: none"> • On • Off <p> Note <input type="checkbox"/> Default: On</p>
Prt. Err Report	<p>You can select whether or not to have an error report printed when a printer error or memory error occurs.</p> <ul style="list-style-type: none"> • On • Off <p> Note <input type="checkbox"/> Default: Off</p>

Menu	Description
Auto Continue	<p>You can set whether Auto Continue is enabled. When it is on, printing continues after a system error occurs.</p> <ul style="list-style-type: none"> • Off • 0 minute • 1 minute • 5 minutes • 10 minutes • 15 minutes <p> Note</p> <ul style="list-style-type: none"> <input type="checkbox"/> Default: Off <input type="checkbox"/> When it is on and certain types of error occur, the current job might be canceled, and the next job started automatically.
Memory Overflow	<p>You can select whether the memory overflow error report is printed when the data is too large and cannot be processed.</p> <ul style="list-style-type: none"> • Not Print • Error List <p> Note</p> <ul style="list-style-type: none"> <input type="checkbox"/> Default: Not Print
Sub Paper Size	<p>You can select whether the printer automatically selects the paper tray containing paper of the specified size.</p> <ul style="list-style-type: none"> • Off • Auto <p> Note</p> <ul style="list-style-type: none"> <input type="checkbox"/> Default: Off
Page Size	<p>You can specify the default paper size.</p> <p>11 x 17, 8 1/2 x 14, 11 x 8 1/2, 5 1/2 x 8 1/2, 7 1/4 x 10 1/2, 8 x 13, 8 1/2 x 13, 8 1/4 x 13, A3, B4, A4, B5, A5, A6, 8K, 16K, 4 1/8 x 9 1/2, 3 7/8 x 7 1/2, C5 Env, C6 Env, DL Env, Custom Size</p> <p> Note</p> <ul style="list-style-type: none"> <input type="checkbox"/> Default: 11 x 8 1/2
Edge-Edge Print	<p>You can print on the complete area of an A4 sheet leaving no border on any edge.</p> <p> Note</p> <ul style="list-style-type: none"> <input type="checkbox"/> Default: Off
Duplex	<p>You can select whether you want to print on both sides of each page.</p> <ul style="list-style-type: none"> • Off • Short Edge Bind • Long Edge Bind <p> Note</p> <ul style="list-style-type: none"> <input type="checkbox"/> Default: Off <input type="checkbox"/> This menu appears only when the optional Duplex Unit is installed.

Menu	Description
Output Tray	<p>You can select the default output tray. When you select "Auto Tray Sw.", the printer automatically changes to another output tray if an output tray becomes full. This function is available only when the Mailbox or the 1-bin Shift Sort Tray is installed.</p> <p>Standard Tray, Mailbox Tray 1, Mailbox Tray 2, Mailbox Tray 3, Mailbox Tray 4, Upper Tray, Auto Tray Sw.</p> <p> Note</p> <ul style="list-style-type: none"> <input type="checkbox"/> Default: Standard Tray <input type="checkbox"/> Only the installed trays appear on the panel display.
Job Separation	<p>You can enable Job Separation.</p> <ul style="list-style-type: none"> • On • Off <p> Note</p> <ul style="list-style-type: none"> <input type="checkbox"/> Default: Off <input type="checkbox"/> This menu appears only when the optional 1-bin Shift Sort Tray is installed.
Energy Saver	<p>You can set how many minutes the printer waits before switching to Energy Saver mode. Energy Saver mode reduces electric power consumption.</p> <p>On, Off</p> <p>1 minute, 5 minutes, 15 minutes, 30 minutes, 45 minutes, 60 minutes</p> <p> Note</p> <ul style="list-style-type: none"> <input type="checkbox"/> Default: On <input type="checkbox"/> Default: 30 minutes <input type="checkbox"/> If there is an error with the printer, the printer will not switch to Energy Saver mode. <input type="checkbox"/> When the printer switches to Energy Saver mode, the Power indicator turns off while the On Line indicator stays on.
Memory Usage	<p>You can select memory to be used from "Font Priority" or "Frame Priority" according to the paper size, resolution or printer language.</p> <ul style="list-style-type: none"> • Font Priority This setting uses memory for registering fonts. • Frame Priority This setting uses memory for high speed printing. <p> Note</p> <ul style="list-style-type: none"> <input type="checkbox"/> Default: Frame Priority <p> Reference</p> <p>For more information, see p.153 "Memory Capacity and Paper Size".</p>
Unit Of Measure	<p>You can select "mm" or "inch" for the custom paper sizes.</p>

Menu	Description
Edge Smoothing	<p>You can set whether Edge Smoothing is enabled. When it is on, jagged lines appear more smoothly. Set it to off when the print image contains fine gradation in tone.</p> <ul style="list-style-type: none"> • On • Off <p> Note</p> <ul style="list-style-type: none"> <input type="checkbox"/> Default: On <input type="checkbox"/> If "Toner Saving" is "On", "Edge Smoothing" is ignored even if it is "On".
Resolution	<p>You can set the print resolution in dots per inch.</p> <ul style="list-style-type: none"> ◆ PCL 300 dpi, 600 dpi ◆ PS 300 dpi, 600 dpi, 1200 dpi ◆ TIFF 200 dpi, 300 dpi, 400 dpi, 600 dpi, 1200 dpi <p> Note</p> <ul style="list-style-type: none"> <input type="checkbox"/> Default: 600 dpi
Toner Saving	<p>You can select whether or not Toner Saving is enabled.</p> <ul style="list-style-type: none"> • On • Off <p> Note</p> <ul style="list-style-type: none"> <input type="checkbox"/> Default: Off <input type="checkbox"/> If "Toner Saving" is "On", "Edge Smoothing" is ignored even if it is "On".
Spool Printing	<p>You can select whether all of the print data is spooled to the Hard Disk Drive before printing.</p> <ul style="list-style-type: none"> • On • Off <p> Note</p> <ul style="list-style-type: none"> <input type="checkbox"/> Default: Off <input type="checkbox"/> Spooling stores the print job sent by a computer temporarily in the printer, transfers the print job, and then prints it. <input type="checkbox"/> This menu appears only when the optional Hard Disk Drive is installed.

Changing the System Menu

- 1 Press **[Menu]**.

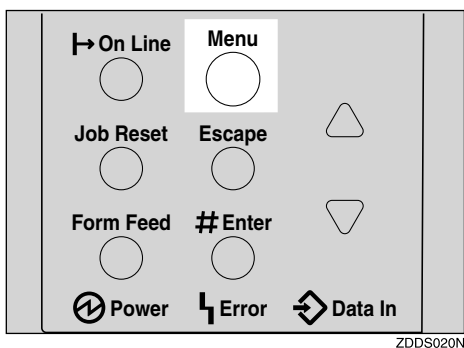

“Menu” appears on the panel display.

- 2 Press **[▲]** or **[▼]** to display the “System” menu.

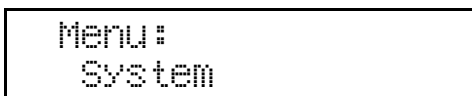

- 3 Press **[Enter #]**.

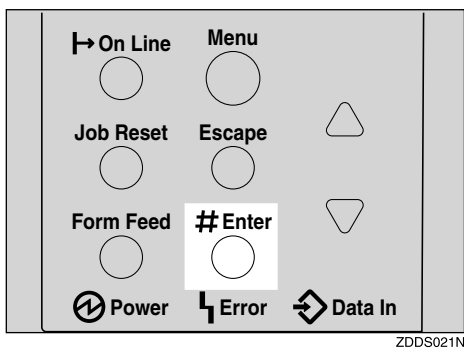

The following message appears on the panel display.

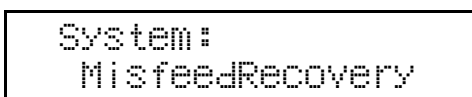

- 4 Press **[▲]** or **[▼]** to display “Energy Saver”.

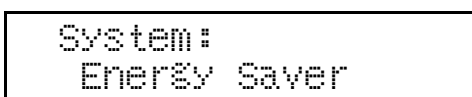

5 Press **[Enter #]**.

The following message appears on the panel display.

```
Energy Saver:
E.Saver On/Off
```

6 Press **[▲]** or **[▼]** to display "E. Saver Timer".

```
Energy Saver:
E. Saver Timer
```

7 Press **[Enter #]**.

The following message appears on the panel display.

```
Energy Saver:
*30 minutes
```

8 Press **[▲]** or **[▼]** to select how many minutes the printer waits before switching to Energy Saver mode.**9** Press **[Enter #]**.

The screen returns to step **6** in a few seconds.

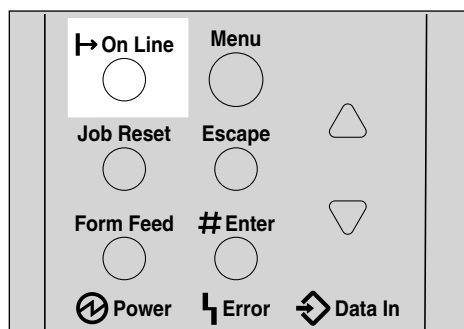
10 Press **[On Line]**.

ZDDS022N

"Ready" appears on the panel display.



```
Ready
```









Host Interface Menu







There are six menu items in the “Host Interface” menu.





- I/O Buffer
- I/O Timeout
- Network Setup
- IEEE 1394 Setup
- IEEE 802.11b
- USB Setting





Host Interface Parameters

Menu	Description
I/O Buffer	<p>You can set the size of the I/O Buffer. Normally it is not necessary to change this setting.</p> <p>16 KB, 32 KB, 64 KB, 128 KB, 256 KB, 512 KB</p> <p> Note</p> <p><input type="checkbox"/> Default: 128 KB</p>
I/O Timeout	<p>You can set how many seconds the printer waits before ending a print job if more data is not received when using parallel interface and USB. If data from another port often appears in the middle of a print job, you should increase the timeout value.</p> <p>10 seconds, 15 seconds, 20 seconds, 25 seconds, 60 seconds</p> <p> Note</p> <p><input type="checkbox"/> Default: 15 seconds</p>

Menu	Description
Network Setup	<p> Note</p> <p><input type="checkbox"/> Items only appear in the Network Setup when the related options are installed. "IEEE 1394 Setup" appears only when the optional IEEE 1394 board is installed. "IEEE 802.11b" appears only when the optional IEEE 802.11b board is installed.</p> <p> Reference</p> <p>For more information about the "Network Setup", see "Configuring the Printer for the Network" in the Setup Guide.</p> <p>For more information about the "IEEE 1394 Setup", see "Configuring the Printer for the Network" in the Setup Guide.</p> <p>For more information about the "IEEE 802.11b", see "Configuring the Printer for the Network" in the Setup Guide.</p> <p> IP Address</p> <p>You can set the IP Address.</p> <p> Note</p> <p><input type="checkbox"/> Default: 011.022.033.044</p> <p> Subnet Mask</p> <p>You can set the Subnet Mask.</p> <p> Note</p> <p><input type="checkbox"/> Default: All zero</p> <p> Gateway Address</p> <p>You can set the Gateway Address.</p> <p> Note</p> <p><input type="checkbox"/> Default: All zero</p>

Menu	Description
Network Setup	<p>❖ Network Boot You can set how the Network Interface Board acquires TCP/IP settings.</p> <p> Note <input type="checkbox"/> Default: None</p> <p>❖ Frame Type (NW) You can set the Frame Type for NetWare.</p> <p> Note <input type="checkbox"/> Default: Auto</p> <p>❖ Active Protocol You can set the active protocol. TCP/IP, NetWare, NetBEUI, AppleTalk</p> <p> Note <input type="checkbox"/> Default: All Active</p> <p>❖ Ethernet You can select the speed of the network to which the printer is connected. Auto, 10 Mbps, 100Mbps</p> <p> Note <input type="checkbox"/> Default: Auto</p> <p>❖ LAN Type You can select Ethernet or IEEE 802.11b for the LAN type.</p> <p> Note <input type="checkbox"/> Default: Ethernet <input type="checkbox"/> Appears only when the optional 802.11b Interface Unit is installed in the Network standard model.</p> <p> Reference For more information about Network Setup, see "Configuring the Printer for the Network" in the Setup Guide.</p>

Menu	Description
IEEE 1394 Setup ^{*1}	<p>You can make settings for using IEEE 1394. This menu appears only when the optional IEEE 1394 board is installed.</p> <ul style="list-style-type: none"> ❖ IP Address1394 You can set the IP address for IEEE 1394 (IP over 1394).  Note <input type="checkbox"/> Default: All zero ❖ Subnet Mask1394 You can set the Subnet Mask for IEEE 1394 (IP over 1394).  Note <input type="checkbox"/> Default: All zero ❖ IP over 1394 You can activate IP over 1394.  Note <input type="checkbox"/> Default: Active ❖ SCSI print You can activate SCSI print.  Note <input type="checkbox"/> Default: Activate ❖ Bidi-SCSI print You can activate bidirectional transmission for SCSI print.  Note <input type="checkbox"/> Default: Activate

Menu	Description
IEEE 802.11b ^{*2}	<p>You can make settings for using the wireless LAN. This menu appears only when the optional IEEE 802.11b board is installed.</p> <ul style="list-style-type: none"> ◆ Comm.Mode You can set the transmission mode for IEEE 802.11b. <ul style="list-style-type: none">  Note <input type="checkbox"/> Default: Ad hoc ◆ Channel The selectable channels are 1-11 (Inch version) and 1-13 (Metric version). <ul style="list-style-type: none">  Note <input type="checkbox"/> Default: 11 ◆ Trans. Speed You can set the transmission speed for IEEE 802.11b. <ul style="list-style-type: none">  Note <input type="checkbox"/> Default: Auto ◆ WEP Settings You can set the code for IEEE 802.11b. <ul style="list-style-type: none">  Note <input type="checkbox"/> Default: Not Active <input type="checkbox"/> You need to set the WEP code key from the network before making this setting. Without the key, transmission cannot be performed. <input type="checkbox"/> Be sure to set the key before setting the code to "Active".
USB Setting ^{*3}	<p>You can set the transmission speed for USB.</p> <ul style="list-style-type: none">  Note <input type="checkbox"/> Default: Auto

^{*1} Appears only when the 1394 Interface Unit board is installed.

^{*2} Appears only when the 802.11b Interface Unit board is installed.

^{*3} While the printer is Online, press **[Enter #]**, and then press **[Escape]**. Finally, press **[Menu]**. You can access the "USB Setting" menu on the panel display.

Changing the Host Interface Menu

- 1 Press **[Menu]**.

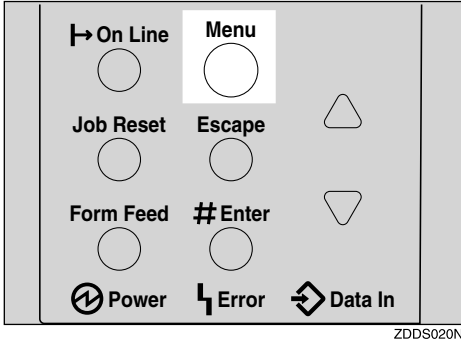

“Menu” appears on the panel display.

- 2 Press **[▲]** or **[▼]** to display the “Host Interface” menu.



- 3 Press **[Enter #]**.

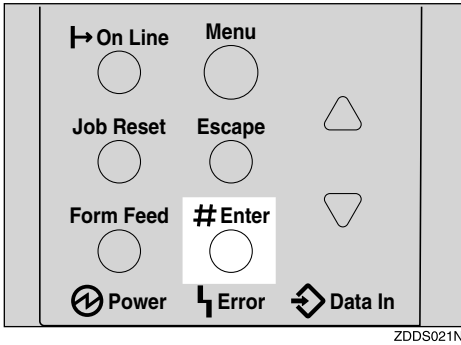

The following message appears on the panel display.

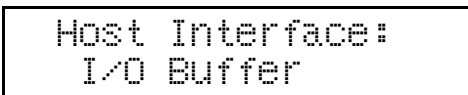

- 4 Press **[▲]** or **[▼]** to display “I/O Timeout”.

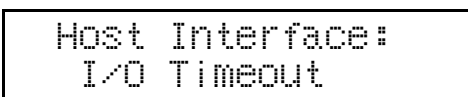

5 Press **[Enter #]**.

The following message appears on the panel display.

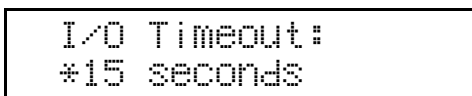

6 Press **[▲]** or **[▼]** to select how many minutes the printer waits before ending a print job.

7 Press **[Enter #]**.

The screen returns to step **4** in a few seconds.

8 Press **[On Line]**.

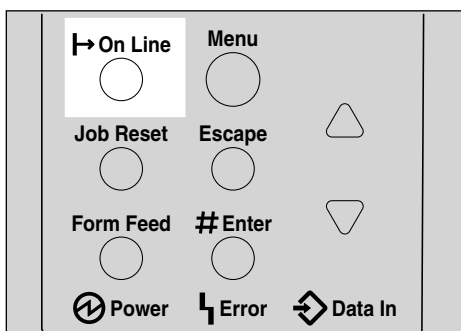

ZDDS022N

“Ready” appears on the panel display.











PCL Menu

There are eight menu items in the “PCL Menu” .

- Orientation
- Form Lines
- Font Source
- Font Number
- Point Size
- Font Pitch
- Symbol Set
- Ext. A4 Width

PCL Parameters

Menu	Description
Orientation	<p>You can set the page orientation.</p> <ul style="list-style-type: none"> • Portrait • Landscape <p> Note</p> <p><input type="checkbox"/> Default: Portrait</p>
Form Lines	<p>You can set the number of lines per page. 5-128</p> <p> Note</p> <p><input type="checkbox"/> Default: 64 (Metric version), 60 (Inch version)</p>
Font Source	<p>You can set the location of the default font.</p> <ul style="list-style-type: none"> • Internal • Download • HDD <p> Note</p> <p><input type="checkbox"/> Default: Internal</p> <p><input type="checkbox"/> When you select "Download", you can select only fonts downloaded to printer RAM.</p>
Font Number	<p>You can set the ID of the default font you want to use.</p> <ul style="list-style-type: none"> • 0 to 50 (for Internal) • 1 to downloaded number <p> Note</p> <p><input type="checkbox"/> Default: Internal</p> <p><input type="checkbox"/> Default: 0</p>

Menu	Description
Point Size	<p>You can set the point size you want to use for the default font. 4 to 999.75 by 0.25</p> <p> Note</p> <ul style="list-style-type: none"> <input type="checkbox"/> Default: 12.00 <input type="checkbox"/> This setting is effective only for a variable-space font.
Font Pitch	<p>You can set the number of characters per inch you want to use for the default font. 0.44 to 99.99 by 0.01</p> <p> Note</p> <ul style="list-style-type: none"> <input type="checkbox"/> Default: 10.00 <input type="checkbox"/> This setting is effective only for a fixed-space font.
Symbol Set	<p>You can specify the set of print characters for the default font. The available options are as follows.</p> <p>Roman-8, ISO L1, ISO L2, ISO L5, PC-8, PC-8 D/N, PC-850, PC-852, PC8-TK, Win L1, Win L2, Win L5, Desktop, PS Text, VN Intl, VN US, MS Publ, Math-8, PS Math, VN Math, Pifont, Legal, ISO 4, ISO 6, ISO 11, ISO 15, ISO 17, ISO 21, ISO 60, ISO 69, Win 3.0</p> <p> Note</p> <ul style="list-style-type: none"> <input type="checkbox"/> Default: Roman-8
Ext. A4 Width	<p>You can extend the width of the printable area for an A4 sheet leaving a narrow margin on the sides.</p> <p> Note</p> <ul style="list-style-type: none"> <input type="checkbox"/> Default: Off

Changing the PCL Menu

1 Press [Menu].

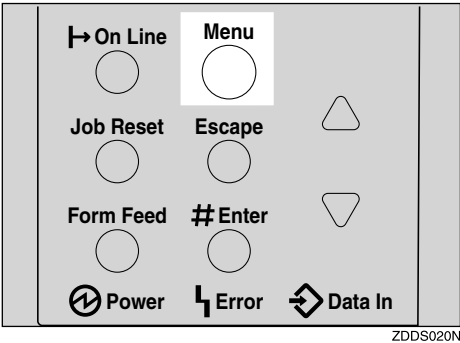

"Menu" appears on the panel display.

2 Press [▲] or [▼] to display "PCL Menu", and then press [Enter #].

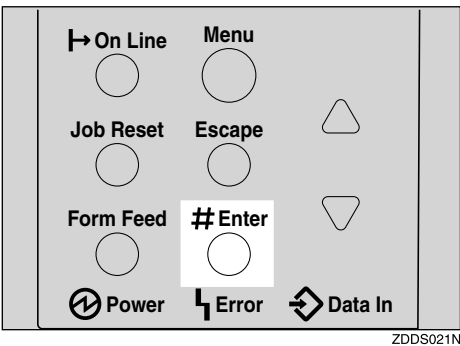

The following message appears on the panel display.

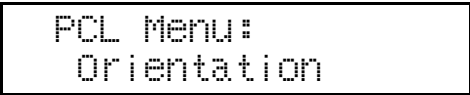

3 Press [Enter #].

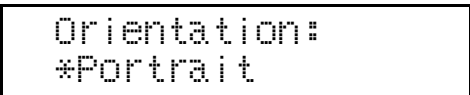

4 Press [▲] or [▼] to select the orientation desired, and then press [Enter #].
Wait for a few seconds.

The screen returns to step **2** in a few seconds.

5 Press **[On Line]**.

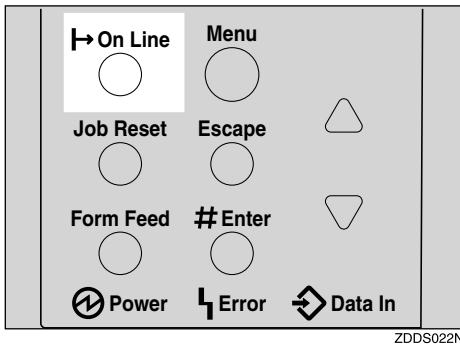

"Ready" appears on the panel display.



6

Language Menu

You can select the language you use. Available language as are follows:

English, French, German, Italian, Spanish, Dutch, Swedish, Norwegian, Danish, Finnish, Portuguese, Czech, Polish, Hungarian

Note

Default: English

Changing the Language Menu

You can change the language by the following procedures below.

1 Press **[Menu]**.

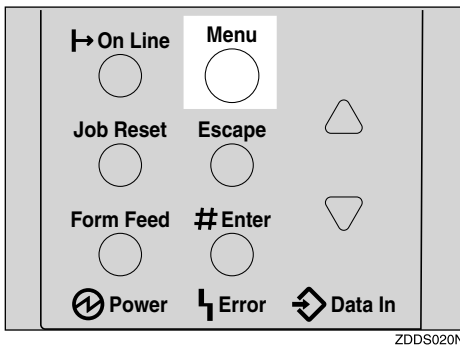

"Menu" appears on the panel display.

2 Press **[▲]** or **[▼]** to display "Language" menu.

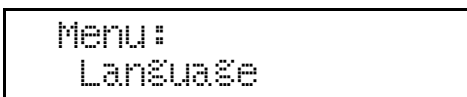

3 Press **[Enter #]**.

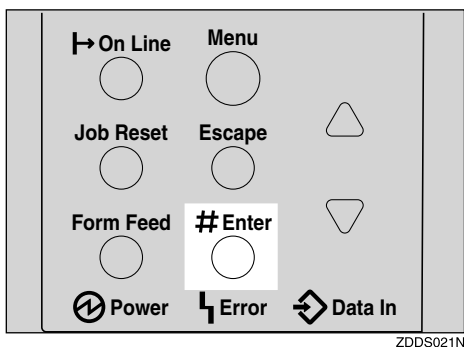

The following message appears on the panel display.

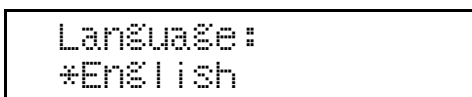

4 Press **[▲]** or **[▼]** until the language you want to select appears on the panel display.

6

5 Press **[Enter #]**. Wait for a few seconds.

The screen returns to step **2** in a few seconds.

6 Press **[On Line]**.

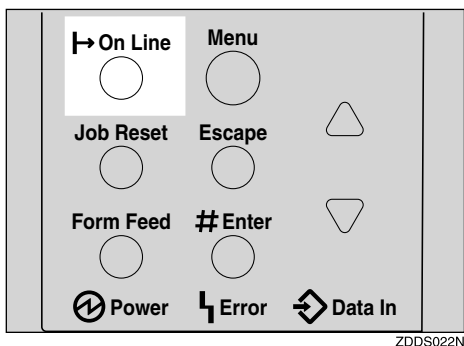

"Ready" appears on the panel display.



Replacing Parts

The maintenance kit contains parts necessary for maintaining the printer. When “Replace Maintenance Kit” appears on the panel display, install the replacement parts included in the maintenance kit.

 **WARNING:**

- *It is dangerous to handle the plug with wet hands. An electric shock might occur.*

 **CAUTION:**

- *The inside of the machine could be very hot. Do not touch the parts with a label indicating "⚠" (means hot surface). Touching "⚠" (means hot surface) could result in a burn.*
- *When you pull the plug out of the socket, grip the plug to avoid damaging the cord and causing a fire or an electric shock.*
- *Be sure to turn off the printer and wait for about an hour before replacing parts. Not waiting for the printer to cool down can result in a burn.*





 **Note**

- If you dispose of the used parts yourself, dispose of them according to local regulations.

MAINTENANCE KIT Type 2600

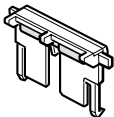
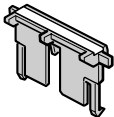
Checking the contents of the box

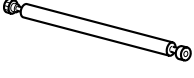
Check the contents of the box according to the following list. If one or more items are missing, contact your sales or service representative.

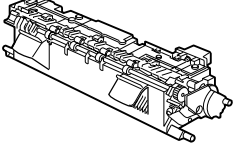
Description	Quantity		
Friction pad for the paper tray (Tray 1)	1 pc		See p.145 "Replacing the Friction Pad".
Friction pad for the Paper Feed Unit (Tray 2, 3)	2 pcs		
Paper feed roller for the paper tray (Tray 1)	1 pc		See p.146 "Replacing the Paper Feed Rollers".
Paper feed roller for the Paper Feed Unit (Tray 2, 3)	2 pcs		
Transfer roller	1 pc		See p.147 "Replacing the Transfer Roller".
Gloves	1 pair		
Fusing Unit	1 pc		See p.149 "Replacing the Fusing Unit".

Preparing to replace the parts

You should replace all the parts included in Maintenance Kit at the same time. Be sure to replace them in the following order:

1 Check the contents of the box for the following items:

- Friction pad for the paper tray (Tray 1)
- Friction pad for the Paper Feed Unit (Tray 2, 3)
- Paper feed roller for the paper tray (Tray 1)
- Paper feed roller for the Paper Feed Unit (Tray 2, 3)
- Transfer roller
- Fusing Unit
- Gloves

2 Confirm that the followings are true:

- The power switch is turned off.
- The power cord is unplugged from the wall outlet.
- The interface cable is unplugged from the printer.

Replacing the Friction Pad

Replace all friction pad of the tray. There are two kinds of friction pads. One is for the paper tray (Tray 1), and the other are for the Paper Feed Unit(s) (Tray 2, 3). The following procedure shows how to replacing friction pad of the paper tray (Tray1).

1 If the optional Duplex Unit, the Mailbox or the 1-bin Shift Sort Tray are installed, uninstall them from the printer.

2 Lift the paper tray slightly then pull it out until it stops.

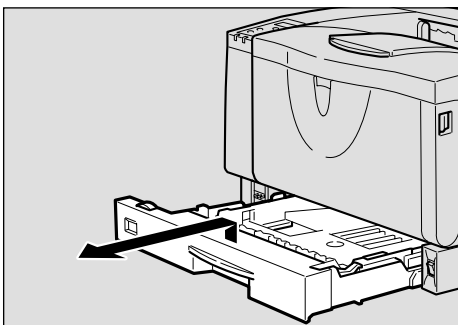

ZCEY430J

3 While lifting the front side of the tray, pull it out of the printer.

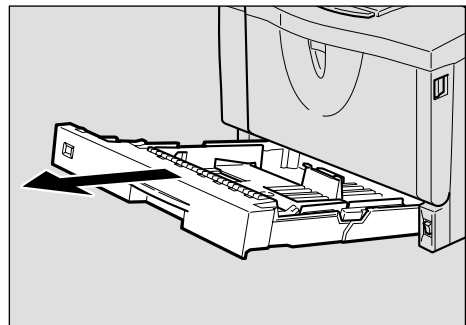

ZCEY140J

4 Remove paper from the paper tray. Place the tray upside down on a flat surface.

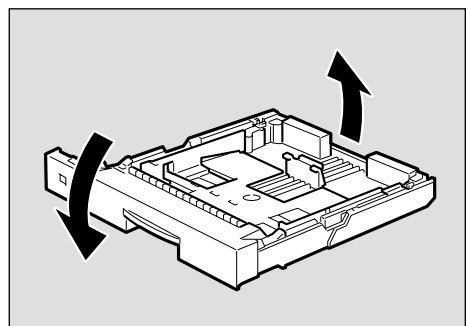

ZCEM160J

- 5** Use a sharp-pointed item like a ball-point pen, to release the two catches that lock the friction pad.

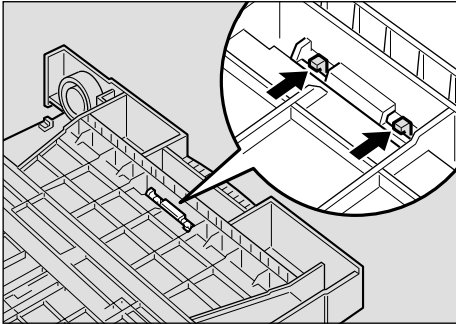

ZCEM170J

- 6** Return the paper tray to its original position, and remove the friction pad from the tray.

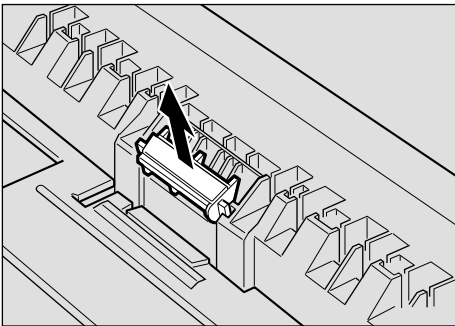

ZCEM180J

- 7** Insert the new friction pad in the paper tray.

Attach the center projection of the new friction pad to the spring and align the projection of both sides of the friction pad to the holes of the paper tray. Then push the friction pad as shown in the illustration until it clicks.

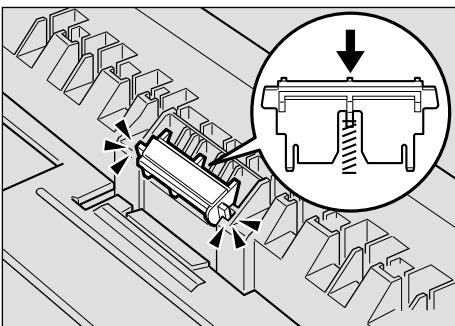

ZCEM190J

- 8** Push the friction pad until it locks securely.

- 9** If your printer is equipped with the optional Paper Feed Unit(s), follow the same procedure when replacing the friction pad.

Replacing the Paper Feed Rollers

Replace all feed rollers including the printer and the optional Paper Feed Unit(s). The following procedure shows how to replacing the paper feed rollers of the printer.

⚠ CAUTION:

- When lifting the machine, use the inset grips on both sides. Otherwise the printer could break or cause injury if dropped.

- 1** Move the printer to the edge of a sturdy and stable table or desk.

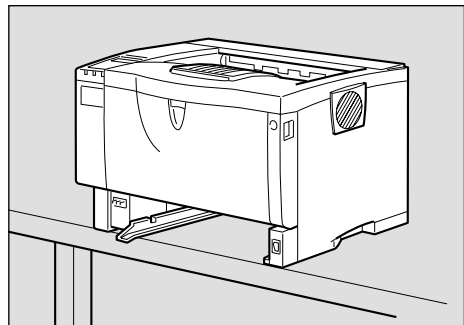

ZGDM110J

⚠ Important

- Be sure to move the printer horizontally. Moving the printer facing up on down may cause the toner to scatter.
- Do not put the printer on an unstable or tilted surface.

Note

- ❑ If the printer is equipped with the optional Paper Feed Unit, do not move the printer and the unit together, they are not securely attached.

- 2** Slide the green lock lever to the right (①), remove the paper feed roller (②).

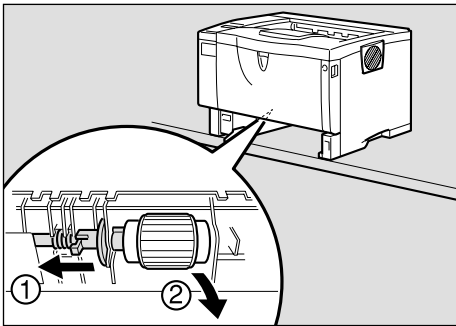

ZGDM120J

- 3** While sliding the green lock lever to the right (①), set the new roller (②). After that, return the green lock lever to its original position (③).

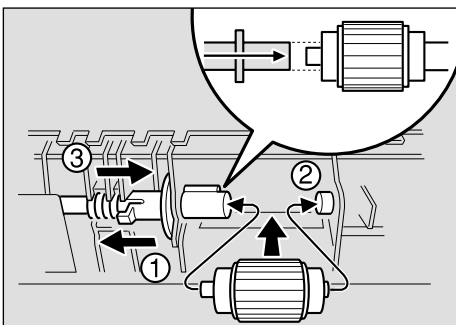

ZCEM130J

Note

- ❑ Confirm that the green lock lever secures the roller correctly by checking if the new roller rotates smoothly.

- 4** If the printer is equipped with the optional Paper Feed Unit(s), follow the same procedure when replacing the paper feed roller.

If you installed two Paper Feed Units, also replace both paper feed rollers.

- 5** Leave the paper tray pulled out and go to p.147 "Replacing the Transfer Roller".

Replacing the Transfer Roller

- 1** Open the front cover by pushing the front cover release button.

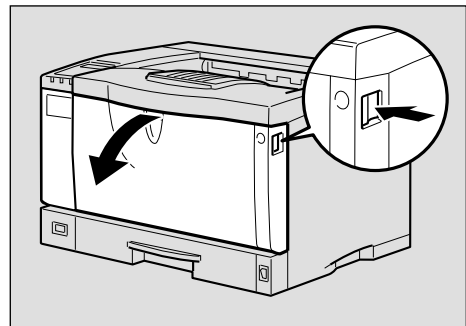

ZCEH120J

- 2** Pull the toner cartridge out of the printer, while lifting the front side.

Note

- ❑ Be sure to place the used cartridge on the level place.

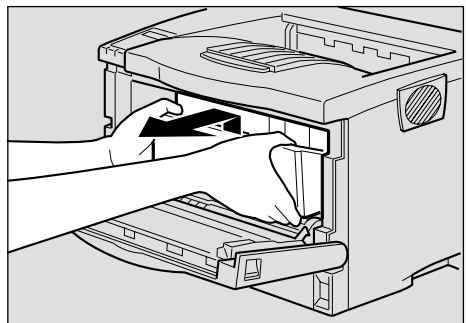

ZGDT110J

3 To avoid making your hands dirty with toner from the transfer roller, wear the gloves included in the maintenance kit.

4 Hold the lock levers (“●” parts), and pull them.

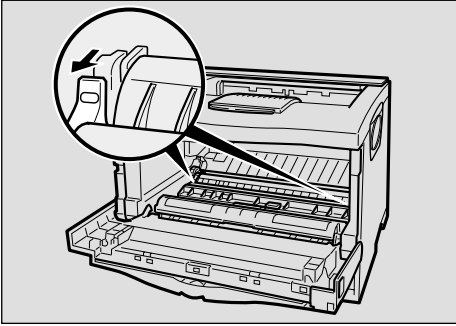

ZCEM200J

5 Hold the green parts of the roller on both sides, and remove the roller from the printer as shown in the illustration.

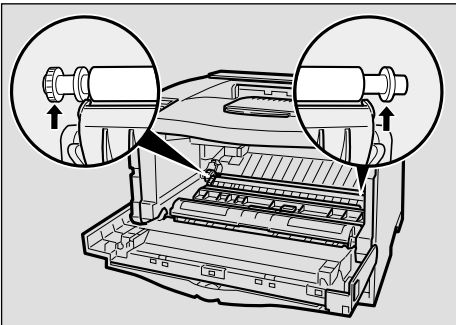

ZCEM210J

6 Insert the new transfer roller on the socket with the gear of the roller positioned on the left.

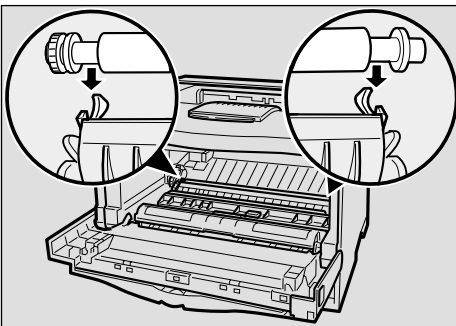

ZCEM220J

Important

- Do not insert the roller on the back of the socket, or the printer might be damaged.
- Insert the metallic part of the roller on the socket. If you insert the sponge part of the roller, the roller might be damaged.

7 Push down the green parts of both sides of the printer until it clicks as shown in the illustration.

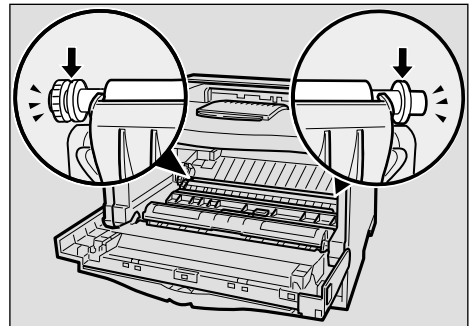

ZCEM221J

Note

- When the transfer roller is set, the transfer roller cover will return to its original position automatically.

8 Holding the grips of the toner cartridge, insert it into the printer until it stops.

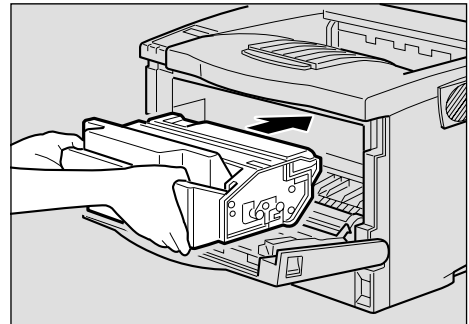

ZGDT120J

- 9** Push down the toner cartridge to insert it in its appropriate position.

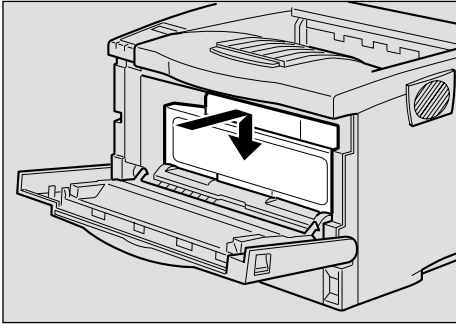

ZGDT140J

- 10** Close the front cover.

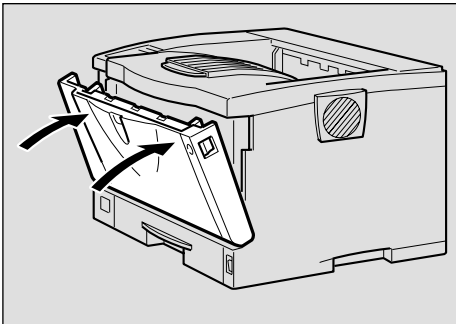

ZGDH130J

- 11** Take the gloves off and go to p.149 "Replacing the Fusing Unit".

Replacing the Fusing Unit

⚠ CAUTION:

- The fusing unit becomes very hot. When installing the new fusing unit, turn off the printer and wait about an hour. After that, install the new fusing unit. Not waiting for the unit to cool down can result in a burn.

- 1** If the rear cover is attached to the printer, remove it.

- 1** Open the rear cover by pushing the two knobs.

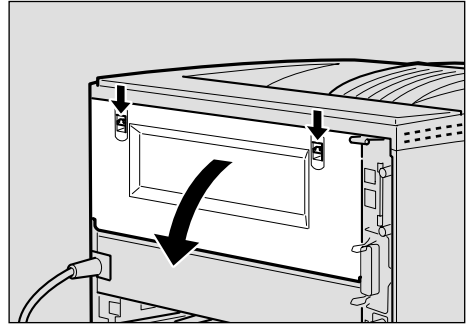

ZGDY210J

- 2** Remove the rear cover in a horizontal direction.

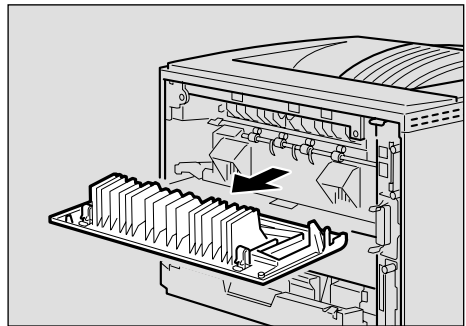

ZGDY220J

- 2** Lift the lock levers of the fusing unit as shown in the illustration.

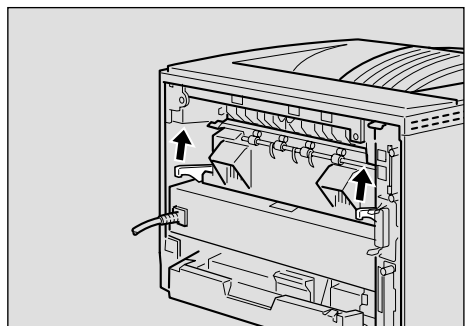

ZGDY222N

3 Pull the fusing unit out.

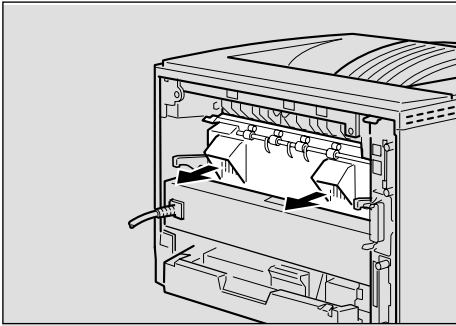

ZGDX223N

4 Replace the new fusing unit into the printer.

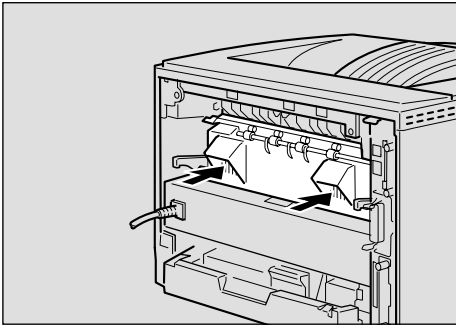

ZGDX224N

5 Push the lock levers of the fusing unit down until it clicks.

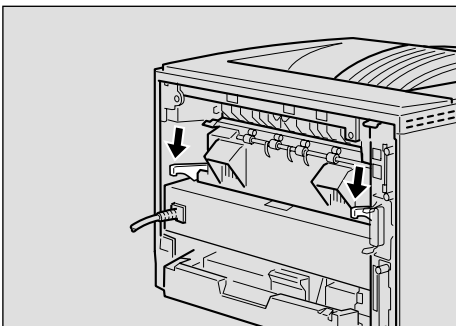

ZGDX225N

6 Insert the rear cover to the inside grooves on both sides of the printer in a horizontal direction.

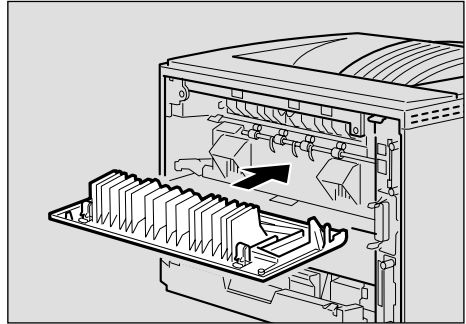

ZGDX221J

7 Close the rear cover.

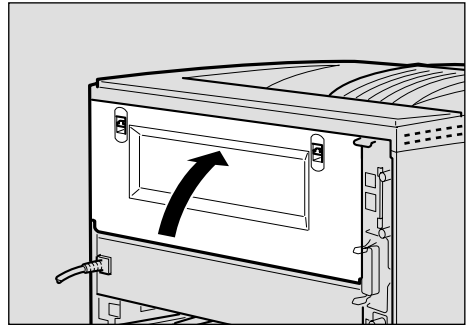

ZGDX211N

8 Print a configuration page to confirm that the printer works properly.

Reference

For more information about printing the configuration page, see "List/Test Print Menu" in the Printer Reference provided as a PDF file on the CD-ROM labeled "Operating Instructions".

Collate and Shift Collate

Reference

For more information about collate and shift collate, see the printer driver's Help file.

Collate

Outputs can be assembled as sets in sequential order.

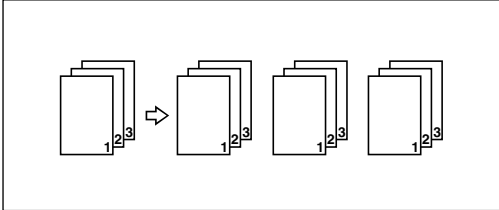

Shift Collate

The shift tray moves backward or forward each time the copies of one set or those of each job are delivered, and makes the next copy to shift when delivered to differentiate each set or jobs.

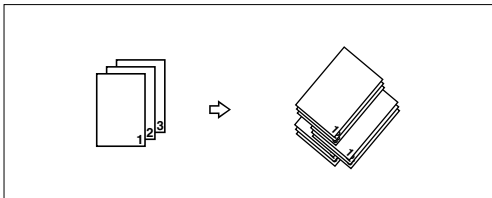

Limitation

- To use these functions, the optional Memory Unit of at least 96 MB or the optional Hard Disk Drive must be installed on the printer.
- Up to 200 pages can be sorted using RAM. If the optional Hard Disk Drive is installed, up to 1000 pages can be sorted. The maximum number of pages to be sorted is 200 pages.
- Shift Collate requires the optional 1-bin Shift Sort Tray to be installed on the printer.

Note

- When using PostScript 3, if you select Upper Tray as an output tray, it is shift collated automatically. When using RPCS, you can select collate function.

Spool Printing

With spool printing, the whole data of a print job is saved in the Printer Hard Disk before printing. To use this function, set it from the menu. See p.124 "System Menu".

Important

- Do not turn off the printer or the computer when a print job is being spooled and the **Data In** indicator is blinking. If you do, the print job will remain in the Printer Hard Disk and be printed when the printer is turned on.

Limitation

- Spool printing does not appear unless the optional Hard Disk Drive is installed.
- Data that has been received in the protocol other than LPD or IPP cannot be spooled.
- Up to 50 jobs (approximately 500 MB) can be spooled at a time.
- When spool printing is on, the size of a single print job cannot exceed 500 MB.
- When sending spooled print jobs from more than one computer at the same time, up to five LPR jobs and one IPP job can be spooled. Jobs exceeding the maximum number cannot be spooled. Wait until the number of spooled print jobs falls below the maximum.

Note

- When "On" is selected, the first print will take time.

Confirm or delete the spooled job from a Web browser.

The spooled job can be seen or deleted from a Web browser. Start a Web browser, and then input the IP address of the printer for URL to show the top page. Click **[Admin Info.]**, and then click **[Spool Printing]**. Select the file, check for delete, input the password, and then click the delete button. (The default password is "password".)

Memory Capacity and Paper Size

The following tables show the typical memory requirements of the RPCS printer language. Memory requirements depend on your print data and printing environment, such as the "Memory Priority" setting or total memory size that the printer has available. The print mode also effects whether the print job will equally completed.

Setting of the "Frame Priority"

Paper Size	Memory Capacity	Resolution (dpi)	
		600 x 600	1200 x 1200
B5	32MB	○	○
	96MB	○	○
A4 (210 × 297) Letter (8 ¹ / ₂ ×11)	32MB	○	○
	96MB	○	○
B4	32MB	○	○
	96MB	○	○
A3 (11 × 17)	32MB	○	○*
	96MB	○	○

○

Means that the print job is supported by simplex and duplex printing.

○*

Means it might be impossible to print images complex data with duplex printing. Even with simple data, the number of pages printed with duplex printing might be limited.

Setting of the “Font Priority”

Paper Size	Memory Capacity	Resolution (dpi)	
		600 x 600	1200 x 1200
B5	32MB	○	○
	96MB	○	○
A4 (210 × 297) Letter (8 ¹ / ₂ ×11)	32MB	○	○*
	96MB	○	○
B4	32MB	○	○*
	96MB	○	○
A3 (11 × 17)	32MB	○	●*
	96MB	○	○

○

Means that the print job is supported by simplex and duplex printing.

○*

Means it might be impossible to print images complex data with duplex printing. Even with simple data, the number of pages printed with duplex printing might be limited.

●*

Means it might be impossible to print images complex data with printing. Even with simple data, the number of pages printed with printing might be limited.

Moving and Transporting the Printer

⚠ CAUTION:

- When lifting the machine, use the inset grips on both sides. Otherwise the printer could break or cause injury if dropped.
- When you move the printer, remember to unplug the power cord from the wall outlet to avoid a fire or an electric shock.
- When you pull out the plug from the socket, grip the plug to avoid damaging the cord and causing a fire or an electric shock.

Repack the printer in its original packing materials for transporting.

⚠ Important

- ❑ Be sure to disconnect all cables from the printer before transporting it.
- ❑ The printer is a precision piece of machinery. Take care to avoid damage during shipment.

Moving the Printer

⚠ CAUTION:

- The machine weight is approximately 18 kg (39.7 lb. bond).
- When lifting the machine, use the inset grips on both sides. Otherwise the printer could break or cause injury if dropped.
- Before moving the machine, unplug the power cord from the outlet. If the cord is unplugged abruptly, it could become damaged. Damaged plugs or cords can cause an electrical or fire hazard.

Moving the printer in the short distance

1 Confirm that the followings are true:

- The power switch is turned off.
- The power cord is unplugged from the wall outlet.
- The interface cable is unplugged from the printer.

2 If you installed external options, remove them.

Removing the Mailbox or the 1-bin Shift Sort Tray

The following procedure shows how to remove the Mailbox as an example.

1 Pull all the upper trays out.

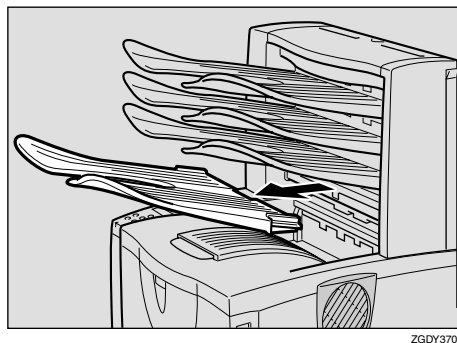

2 While pushing the lock buttons (1), pull the Mailbox out (2).

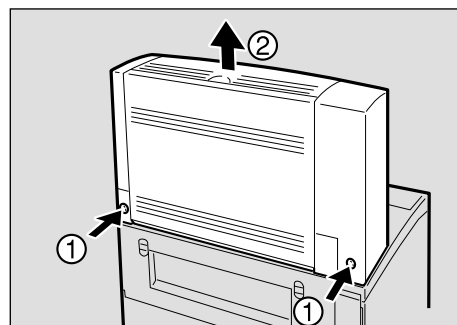

Removing the Duplex Unit

- 1 Push down the lever on right side of the Duplex Unit (①) and pull it out until it stops (②).

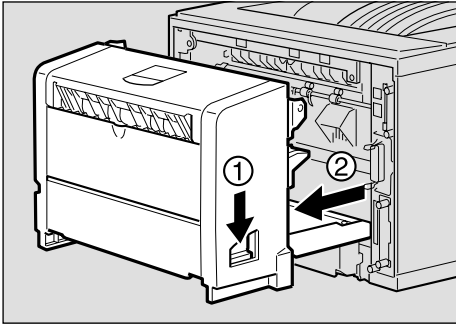

ZGDY320J

- 2 Push the under board levers (①) and pull the Duplex Unit out of the printer (②).

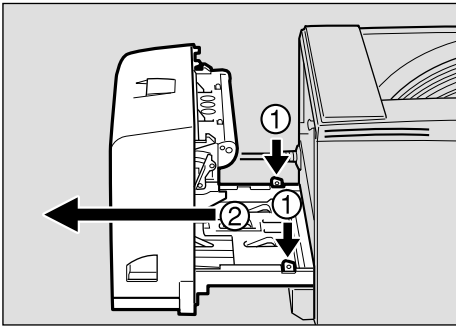

ZCEY450J

- 3 Be sure to close the Bypass Tray and the front cover.

- 4 Lift the printer and move it to the place where you want to install it.

⚠ CAUTION:

- When lifting the machine, use the inset grips on both sides. Otherwise the printer could break or cause injury if dropped.

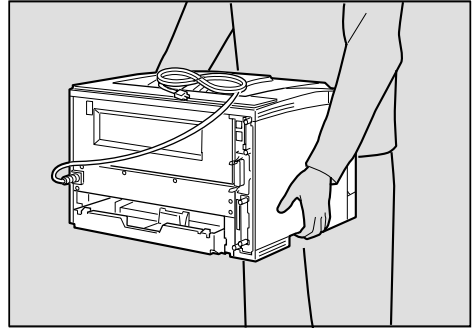

ZGDH221J

⚠ Important

- Be sure to move the printer horizontally. Moving the printer facing up or down may cause the toner to scatter.
- If the Paper Feed Unit(s) is installed, detach and move the printer separately. Never move the printer with the Paper Feed Unit(s) attached.

Specifications

Mainframe

❖ Configuration:

Desktop

❖ Print Process:

Laser beam scanning & Electrophotographic printing

Dual component toner development

❖ Printing Speed:

Maximum 26 pages per minute (A4☐, 8¹/₂ × 11☐)

Note

- ☐ Continuous printing on sheets with a width of 230 mm or smaller may decrease the printing speed depending on the temperature control of the fusing unit.

❖ Interface:

Standard 36-pin printer cable and a parallel port on the host computer
IEEE 1284 I/F (Compatible, ECP, Nibble)

- Do not use a cable more than 2.5 meters (8.2 feet) long.
- USB1.1
- USB2.0
- Bidirectional IEEE1284
- 10/100Base-TX(std.for AP2610N)

❖ Resolution:

1,200 × 1,200 dpi (PCL 6, RPCS, PS)

600 × 600 dpi (PCL 6, PCL 5e, RPCS, PS)

300 × 300 dpi(PCL5e)

❖ Printer Language:

PCL 6 (XL) , PCL 5e, RPCS, Adobe PostScript 3

❖ Fonts:

PCL 6, PCL 5e

Agfa Font Manager 35 Intellifonts, 10 TrueType fonts, and 1 bitmap font
Font Manager available, plus 31 additional fonts.

PostScript

136 fonts(Type 2:24, Type 14:112)

❖ Paper size:

See p.25 “Paper and Other Media Supported by This Printer”

❖ **Paper Weight:**

See p.25 “Paper and Other Media Supported by This Printer”

❖ **Power Source:**

120V, 60 Hz, 8.4A or more

❖ **Power Consumption:**

Maximum	870 W or less
Printing	610 W or less
Energy Saver	<ul style="list-style-type: none"> • Basic model: 12 W • Network standard model: 13 W

❖ **Noise Emission ^{*1}:**

Sound Power Level

	Mainframe only
During Printing	63 dB (A)
Stand-by	40 dB (A)

Sound Pressure level ^{*2}

	Mainframe only
During Printing	52 dB (A)

^{*1} The following measurements are actual values made in accordance with ISO7779.

^{*2} Measured at the position of a bystander.

❖ **Dimensions: ^{*1}**

	Width	Depth	Height
Printer only (tray not extended)	478 mm (18.4 inches)	437 mm (17.2 inches)	305 mm (12.0 inches)
Printer only (tray extended)	478 mm (18.4 inches)	555 mm (21.9 inches)	305 mm (12.0 inches)
With one optional feed unit	478 mm (18.4 inches)	555 mm (21.9 inches)	434 mm (17.1 inches)
With two optional feed units	478 mm (18.4 inches)	555 mm (21.9 inches)	562 mm (22.1 inches)

^{*1} Measurement conditions: With paper tray, Bypass Tray and output tray extension closed.

❖ **Weight:**

Approximately 18 kg (39.7 lb. bond) (toner cartridge and power cord included)

❖ **Warm-up Time:**

Less than 19 seconds (23°C, 73F)

❖ **Paper Capacity:**

Standard paper tray	250 sheets * ¹ (80g/m ² , 20 lb.bond)
Bypass Tray * ²	100 sheets * ¹ (80g/m ² , 20 lb.bond)
Optional Paper Feed Unit × 2	500 sheets × 2 * ¹ (80g/m ² , 20 lb.bond)
Optional Envelope Feeder * ³	60 envelopes * ⁴

*¹ Paper weight: 60 – 105 g/m² (16 – 28 lb. bond)

*² You can load up to 10 envelopes (55 – 157 g/m², 14 – 42 lb. bond) at the same time.

*³ To use the Envelope Feeder Unit, the optional Paper Feed Unit is required. The paper tray of the feed unit can be replaced with the Envelope Feeder Unit.

*⁴ For more information about envelopes, see p.33 “Types of Paper and Other Media”.

❖ **Paper Output Capacity:**

250 sheets (80 g/m², 20 lb. bond)

❖ **Memory:**

Standard 32MB, up to 96MB (with the optional Memory Unit)

❖ **Network (Basic model printer requires the optional Network Interface Board):**

Topology: Ethernet (10BaseT/100BaseTX)

Protocol: TCP/IP, NetBEUI, IPX/SPX, AppleTalk

❖ **Optional Equipment:**

Common for the Basic model printer and the Network standard model printer

- Paper Feed Unit Type 2600
- Envelope Feeder Type 2600
- 1-bin Shift Sort Tray Type 2600
- CS380 (Mailbox)
- AD410 (Duplex Unit)
- Memory Unit TypeB 64MB
- Hard Disk Drive Type 2600
- 1394 Interface Unit Type 4510
- 802.11b Interface Unit Type A

Unique for the Basic model printer

- Network Interface Board Type 2610

Options

Paper Feed Unit Type 2600

- ❖ **Dimensions (W×D×H):**
468 × 545 × 130 mm (18.4 × 19.7 × 5.1 inches)
(without pins on the unit)
- ❖ **Paper Weight:**
60 – 105 g/m² (16 – 28 lb. bond)
- ❖ **Paper Size:**
See p.25 “Paper and Other Media Supported by This Printer”.

Envelope Feeder Type 2600

- ❖ **Dimensions (W×D×H):**
468 × 410 × 130 mm (18.4 × 16.1 × 5.1 inches)
- ❖ **Paper Weight:**
72 – 90 g/m² (19 – 24 lb. bond)
- ❖ **Paper Size:**
See p.25 “Paper and Other Media Supported by This Printer”.

AD410 (Duplex Unit)

- ❖ **Dimensions (W×D×H):**
380 × 150 × 220 mm (15.0 × 5.9 × 8.7 inches)
- ❖ **Paper Size:**
See p.25 “Paper and Other Media Supported by This Printer”.
- ❖ **Paper Weight:**
60 – 105 g/m² (17 – 28 lb. bond)
- ❖ **Weight:**
5 kg (11.0 lb. bond)

1-bin Shift Sort Tray Type 2600

- ❖ **Dimensions (W × D × H):**
465 × 395 × 160 mm (18.3 × 15.6 × 6.3 inches)
- ❖ **Paper Size:**
See p.25 “Paper and Other Media Supported by This Printer”.
- ❖ **Paper Weight:**
60 – 105 g/m² (16 – 28 lb. bond)
- ❖ **Stack Capacity:**
250 sheets / bin (80 g/m², 20 lb. bond)
- ❖ **Weight:**
3.5 kg (7.7 lb. bond)

CS380 (Mailbox)

- ❖ **Dimensions (W × D × H):**
465 × 395 × 285 mm (18.3 × 15.6 × 11.2 inches)
- ❖ **Paper Size:**
See p.25 “Paper and Other Media Supported by This Printer”.
- ❖ **Paper Weight:**
60 – 105 g/m² (16 – 28 lb. bond)
- ❖ **Stack Capacity:**
50 sheets / bin (80 g/m², 20 lb. bond)
- ❖ **Weight:**
5.5 kg (12.1 lb. bond)

Hard Disk Drive Type 2600

- ❖ **Storage Capacity (Formatted):**
6 GB
You can install PostScript fonts with this optional Hard Disk Drive. With a Macintosh, types of fonts supported are PostScript Type 1 and PostScript Type 2. To download them, use PS Utility for Mac.

Memory Unit TypeB 64MB

- ❖ **Module Type:**
SO-DIMM (Small Outline Dual-in-line Memory Module)
- ❖ **Memory Type:**
SDRAM (Synchronous Dynamic RAM)
- ❖ **Number of Pins:**
144 pins

Network Interface Board Type 2610

- ❖ **Topology:**
Ethernet (10BaseT/100BaseTX)
- ❖ **Protocols:**
TCP/IP, NetBEUI, IPX/SPX, AppleTalk
- ❖ **Interface Connector:**
RJ45
- ❖ **Required Cable:**
STP (Shielded Twisted-Pair) cable
Category / Type5 or better

1394 Interface Unit Type 4510

- ❖ **Transmission Spec.:**
IEEE 1394
- ❖ **Device Class:**
SCSI print, IP over 1394
- ❖ **Interface Connector:**
IEEE 1394 (6 pins × 2)
- ❖ **Required cable:**
1394 interface cable (6 pins × 4 pins, 6 pins × 6 pins)

 Important

- You cannot plug devices together to create loops.
- Do not use a cable more than 4.5 meters (14.8 feet) long.

- ❖ **Connectable number of device in a bus:**
Maximum 63

❖ **Allowed cable hops in a bus:**

Maximum 16

❖ **Power supply:**

Nonpower supply

Cable Power repeated (IEEE 1394a-2000 compliant)

802.11b Interface Unit TypeA (R-WL11)

❖ **Transmission Spec.:**

Based on IEEE 802.11b (Wireless LAN)

❖ **Protocol:**

TCP/IP, NetBEUI, IPX/SPX, AppleTalk

 **Note**

SmartNetMonitor and WebStatusMonitor are supported.

❖ **Data Transfer Speed:**

Auto select from below speed

1Mbps, 2Mbps, 5.5Mbps, 11Mbps

❖ **Frequency Range:**

- Inch version:
2412-2464 Mhz (1-11 channels)
- Metric version:
2412-2472 Mhz (1-13 channels)

❖ **Transmittable Distance:**

1Mbps 400m ^{*1}

2Mbps 270m ^{*1}

5.5Mbps 200m ^{*1}

11Mbps 140m ^{*1}

^{*1} These figures are a guideline for outdoor use. In general, the transmittable distance indoors is 10-100 m, depending on the environment.

❖ **Transmission Mode:**

ad hoc mode and infrastructure mode

Consumables

⚠ CAUTION:

- *Our products are engineered to meet the highest standards of quality and functionality. When purchasing expendable supplies, we recommend using only those specified by an authorized dealer.*

❖ Toner Cartridge

	Printable number of pages per cartridge *1
Toner Cartridge	20,000 pages

*1 A4, 5% test chart

📝 Note

- The actual number of printed pages you get from a particular toner cartridge depends on the type and size of paper you are using, the contents of your print images, and printing environment conditions. All this means that a toner cartridge might require replacement sooner than the normal life described above.
- The number of printable pages that can be expected from the starter toner cartridge included in the printer is about 6,000 pages (A4, 5% chart).

❖ Maintenance Kit

MAINTENANCE KIT Type 2600

It is required to change the maintenance kit after every 90,000 pages have been printed. However, it may be necessary to change the parts earlier depending on their operating period.

Information about Installed Software

expat

Expat(Version 1.1). Copyright 1998, 1999 James Clark. All rights reserved.

- The software installed on this product includes the expat application software Version 1.1 (hereinafter "expat 1.1").
- The product manufacturer has not made any modification to the source code of the expat 1.1.
- The product manufacturer provides warranty and support to the software of the product including the expat 1.1 and the product manufacturer makes Mr. James Clark, the initial developer of the expat 1.1, free from these obligations.
- The expat 1.1 is made available under Mozilla Public License Version 1.1 (hereinafter "MPL 1.1"), and controller software of the product equals the Larger Work as defined in MPL 1.1. The software of this product except the expat 1.1 is licensed to the product manufacturer under separate agreement(s).
- The source code of the expat 1.1 is available at:
ftp://ftp.jclark.com/pub/xml/expat1_1.zip
- MPL 1.1 is also available at:
<http://www.mozilla.org/MPL/MPL-1.1.html>
- Information relating to the expat 1.1 is available at:
<http://www.jclark.com/xml/expat.html>

JPEG LIBRARY

- The software installed on this product is based in part on the work of the Independent JPEG Group.

NetBSD

Copyright Notice of NetBSD

For all users to use this product:

This product contains NetBSD operating system:

For the most part, the software constituting the NetBSD operating system is not in the public domain; its authors retain their copyright.

The following text shows the copyright notice used for many of the NetBSD source code. For exact copyright notice applicable for each of the files/binaries, the source code tree must be consulted.

A full source code can be found at <http://www.netbsd.org/>.

Copyright © 1999, 2000 The NetBSD Foundation, Inc.

All rights reserved.

Redistribution and use in source and binary forms, with or without modification, are permitted provided that the following conditions are met:

- ① Redistributions of source code must retain the above copyright notice, this list of conditions and the following disclaimer.
- ② Redistributions in binary form must reproduce the above copyright notice, this list of conditions and the following disclaimer in the documentation and/or other materials provided with the distribution.
- ③ All advertising materials mentioning features or use of this software must display the following acknowledgment:
This product includes software developed by the NetBSD Foundation, Inc. and its contributors.
- ④ Neither the name of The NetBSD Foundation nor the names of its contributors may be used to endorse or promote products derived from this software without specific prior written permission.

THIS SOFTWARE IS PROVIDED BY THE NETBSD FOUNDATION, INC. AND CONTRIBUTORS "AS IS" AND ANY EXPRESS OR IMPLIED WARRANTIES, INCLUDING, BUT NOT LIMITED TO, THE IMPLIED WARRANTIES OF MERCHANTABILITY AND FITNESS FOR A PARTICULAR PURPOSE ARE DISCLAIMED. IN NO EVENT SHALL THE FOUNDATION OR CONTRIBUTORS BE LIABLE FOR ANY DIRECT, INDIRECT, INCIDENTAL, SPECIAL, EXEMPLARY, OR CONSEQUENTIAL DAMAGES (INCLUDING, BUT NOT LIMITED TO, PROCUREMENT OF SUBSTITUTE GOODS OR SERVICES; LOSS OF USE, DATA, OR PROFITS; OR BUSINESS INTERRUPTION) HOWEVER CAUSED AND ON ANY THEORY OF LIABILITY, WHETHER IN CONTRACT, STRICT LIABILITY, OR TORT (INCLUDING NEGLIGENCE OR OTHERWISE) ARISING IN ANY WAY OUT OF THE USE OF THIS SOFTWARE, EVEN IF ADVISED OF THE POSSIBILITY OF SUCH DAMAGE.

Authors Name List

All product names mentioned herein are trademarks of their respective owners. The following notices are required to satisfy the license terms of the software that we have mentioned in this document:

- This product includes software developed by the University of California, Berkeley and its contributors.
- This product includes software developed by Jonathan R. Stone for the NetBSD Project.
- This product includes software developed by the NetBSD Foundation, Inc. and its contributors.
- This product includes software developed by Manuel Bouyer.
- This product includes software developed by Charles Hannum.
- This product includes software developed by Charles M. Hannum.
- This product includes software developed by Christopher G. Demetriou.
- This product includes software developed by Tools GmbH.
- This product includes software developed by Terrence R. Lambert.
- This product includes software developed by Adam Glass and Charles Hannum.
- This product includes software developed by Theo de Raadt.
- This product includes software developed by Jonathan Stone and Jason R. Thorpe for the NetBSD Project.
- This product includes software developed by the University of California, Lawrence Berkeley Laboratory and its contributors.
- This product includes software developed by Christos Zoulas.
- This product includes software developed by Christopher G. Demetriou for the NetBSD Project.
- This product includes software developed by Paul Kranenburg.
- This product includes software developed by Adam Glass.
- This product includes software developed by Jonathan Stone.
- This product includes software developed by Jonathan Stone for the NetBSD Project.
- This product includes software developed by Winning Strategies, Inc.
- This product includes software developed by Frank van der Linden for the NetBSD Project.
- This product includes software developed for the NetBSD Project by Frank van der Linden
- This product includes software developed for the NetBSD Project by Jason R. Thorpe.
- The software was developed by the University of California, Berkeley.
- This product includes software developed by Chris Provenzano, the University of California, Berkeley, and contributors.

INDEX

1394 interface cable, 162
1394 Interface Unit Type 4510, 162
1-bin Shift Sort Tray Type 2600, 161

A

AD410, 160
adhesive labels, 34
Adjusting the image density, 97
Adjusting the Registration, 98
Auto Continue, 124

B

Bypass size, 106

C

Collate, 151
Config. Page, 110
CS380, 161
Curl Prevention, 114

D

Data In indicator, 77
Duplex, 124

E

Edge-Edge Print, 124
Edge Smoothing, 124
Energy Saver, 124
Envelope Feeder Type 2600, 160
envelopes, 34
envelopes, loading, 45
error, 61
Error indicator, 76
Escape key, 105
Ethernet cable, 162
Ext. A4 Width, 137

F

Font Number, 137
Font Pitch, 137
fonts, 157
Font Source, 137
Form Lines, 137
friction pad, 145
friction pad, cleaning, 93
fusing unit, 149

H

Hard Disk Drive Type 2600, 161
HDD Format, 114
Hex Dump, 110
Host Interface, 104, 130

I

IEEE 1394 Setup, 130
IEEE 802.11b, 130
Image density, 114
I/O Buffer, 130
I/O Timeout, 130

J

Job Separation, 124

K

Key Repeat, 114

L

Language, 104, 141
List/Test Print, 104, 110
List/Test Print Parameters, 110
Locked Print, 56, 104

M

Macintosh
 uninstall, PostScript, 24
Maintenance, 104, 114, 115
MAINTENANCE KIT Type 2600, 144
media, 25
memory, 153, 159
Memory Overflow, 124
Memory Unit TypeB 64MB, 162
Memory Usage, 124
menu, accessing, 104
menu, changing, 141
Menu Chart, 101
Menu key, 104
Menu List, 110
Menu Protect, 114
messages, 61
misfeed, 82
MisfeedRecovery, 124

N

Network Interface Board, 159, 162
Network Printing Guide, ii
Network Setup, 130
NIB, 159

O

OHP transparencies, 34
On Line indicator, 76
On Line key, 76, 105
options, 159, 160
Orientation, 137
Output Tray, 124

P

Page Size, 124
panel display, messages, 61
paper, 25
paper feed roller, 146
paper feed roller, cleaning, 94
Paper Feed Unit Type 2600, 160
Paper Input, 104, 106
paper, loading, 37
paper, sizes, types, 25
Paper type, 106
Parallel cable, 157
PCL, 137
PCL 5e
 Windows 2000, uninstalling, 19
 Windows 95/98/Me, uninstalling, 19
 Windows NT 4.0, uninstalling, 20
 Windows XP, uninstalling, 19
PCL 6
 Windows 2000, uninstalling, 19
 Windows 95/98/Me, uninstalling, 19
 Windows NT 4.0, uninstalling, 20
 Windows XP, uninstalling, 19
PCL Config.Page, 110
PCL Menu, 104
plain paper, 33
Point Size, 137
PostScript
 Macintosh, uninstall, 24
 Windows 2000, uninstalling, 23
 Windows 95/98/Me, uninstalling, 23
 Windows NT 4.0, uninstalling, 24
 Windows XP, uninstalling, 23
Ppr.Size Error, 114
Printer Reference, ii
Prt. Err Report, 124
PS Font List, 110

Q

Quick Installation Guide, ii

R

Registration, 114
registration roller, cleaning, 96
Resolution, 124
ROM Update, 114
RPCS
 Windows 2000, uninstalling, 21
 Windows 95/98/Me, uninstalling, 21
 Windows NT 4.0, uninstalling, 22
 Windows XP, uninstalling, 21

S

Sample Print, 51, 104
SDRAM, 159, 162
Series Prnt.Job, 114
Setup Guide, ii
Shift Collate, 151
specifications, 157
Spool Printing, 124
Sub Paper Size, 124
Symbol Set, 137
System, 104, 124

T

toner cartridge, replacing, 90
Toner Saving, 124
transfer roller, 147
Tray Locking, 106
Tray Paper Size, 106
Tray Priority, 106
troubleshooting, 61

U

Unit Of Measure, 124
USB Setting, 130

W

Windows 2000

- PCL 5e, uninstalling*, 19
- PCL 6, uninstalling*, 19
- PostScript, uninstalling*, 23
- printer properties, PCL*, 2
- printer properties, PostScript*, 12
- printer properties, RPCS*, 7
- RPCS, uninstalling*, 21

Windows 95/98/Me

- PCL 5e, uninstalling*, 19
- PCL 6, uninstalling*, 19
- PostScript, uninstalling*, 23
- printer properties, PCL*, 1
- printer properties, PostScript*, 11
- printer properties, RPCS*, 6
- RPCS, uninstalling*, 21

Windows 95/98/Me, Windows 2000,

Windows XP, Windows NT 4.0

- canceling a job*, 17

Windows NT 4.0

- PCL 5e, uninstalling*, 20
- PCL 6, uninstalling*, 20
- PostScript, uninstalling*, 24
- printer properties, PCL*, 4
- printer properties, PostScript*, 14
- printer properties, RPCS*, 9
- RPCS, uninstalling*, 22

Windows XP

- PCL 5e, uninstalling*, 19
- PCL 6, uninstalling*, 19
- PostScript, uninstalling*, 23
- printer properties, PCL*, 2
- printer properties, PostScript*, 12
- printer properties, RPCS*, 7
- RPCS, uninstalling*, 21

WL.LAN Defaults, 114

WL.LAN Signal, 114



Network Printing Guide

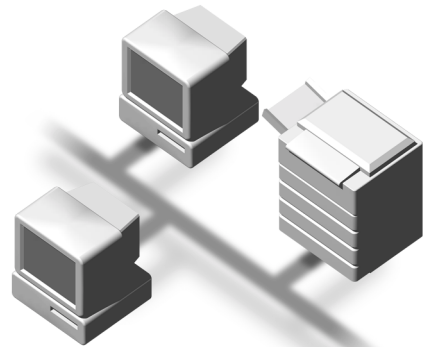

For safety, please read this manual carefully before you use this product and keep it handy for future reference.

Introduction

To get maximum versatility from this machine all operators should carefully read and follow the instructions in this manual. Please keep this manual in a handy place near the machine.

Please read the Safety Information before using this machine. It contains important information related to USER SAFETY and PREVENTING EQUIPMENT PROBLEMS.

Important

Contents of this manual are subject to change without prior notice. In no event will the company be liable for direct, indirect, special, incidental, or consequential damages as a result of handling or operating the machine.

Software Version Conventions Used in this Manual

- NetWare 3.x means NetWare 3.12 and 3.2.
- NetWare 4.x means NetWare 4.1, 4.11 and IntranetWare.

Trademarks

Apple, AppleTalk, EtherTalk, LaserWriter, Macintosh and Mac are registered trademarks of Apple Computer, Inc.

Ethernet is a registered trademark of Xerox Corporation.

Microsoft, Windows and Windows NT are registered trademarks of Microsoft Corporation in the United States and/or other countries.

Netscape and Netscape Navigator are registered trademarks of Netscape Communications Corporation.

Novell, NetWare and NDS are registered trademarks of Novell, Inc.

PostScript is a registered trademark of Adobe Systems, Incorporated.

Sun is a registered trademark of Sun Microsystems, Inc.

SunOS is a trademark of Sun Microsystems, Inc.

Other product names used herein are for identification purposes only and might be trademarks of their respective companies. We disclaim any and all rights in those marks.

The proper names of the Windows operating systems are as follows:

- The product name of Windows® 95 is Microsoft® Windows 95.
- The product name of Windows® 98 is Microsoft® Windows 98.
- The product name of Windows® Me is Microsoft® Windows Millennium Edition (Windows Me).
- The product names of Windows® XP are as follows:
Microsoft® Windows® XP Professional
Microsoft® Windows® XP Home Edition
- The product names of Windows® 2000 are as follows:
Microsoft® Windows® 2000 Advanced Server
Microsoft® Windows® 2000 Server
Microsoft® Windows® 2000 Professional
- The product names of Windows NT® 4.0 are as follows:
Microsoft® Windows NT® Server 4.0
- Microsoft® Windows NT® Workstation 4.0

Manuals for This Machine

The following manuals describe the operational procedures and maintenance of this machine.

To enhance safe and efficient operation of this machine, all users should read and follow the instructions carefully.

❖ **Quick Installation Guide**

Describes how to install the printer.

❖ **Setup Guide**

Provides information about setting up the printer and its options. This manual is provided as a printed manual, and also as a PDF file on the CD-ROM labeled "Operating Instructions".

❖ **Printer Reference**

Describes the procedures and provides necessary information about using this machine. This manual is included as a PDF file on the CD-ROM labeled "Operating Instructions".

❖ **Network Printing Guide**

Describes the procedures and provides necessary information about setting up and using the printer under the network environment. We recommend this manual as your first choice to read, and it is included as a PDF file on the CD-ROM labeled "Operating Instructions" (this manual).

❖ **PostScript 3 Operating Instructions Supplement**

Describes the menus and features you can set using the PostScript 3 printer driver. This manual is provided as a PDF file on the CD-ROM labeled "Operating Instructions".

Note

- There are three CD-ROMs that come with this printer. "Operating Instructions", "Printer Drivers and Utilities", and "Document Management Utility".
- Concerning UNIX information, please visit our web site or consult your authorized reseller.

How to Read This Manual

Symbols

In this manual, the following symbols are used:

 **WARNING:**

This symbol indicates a potentially hazardous situation which, if instructions are not followed, could result in death or serious injury.

 **CAUTION:**

This symbol indicates a potentially hazardous situation which, if instructions are not followed, may result in minor or moderate injury or damage to property.

* The statements above are notes for your safety.

 **Important**

If this instruction is not followed, paper might be misfed, originals might be damaged, or data might be lost. Be sure to read this.

 **Preparation**

This symbol indicates the prior knowledge or preparations required before operating.

 **Note**

This symbol indicates precautions for operation, or actions to take after misoperation.

 **Limitation**

This symbol indicates numerical limits, functions that cannot be used together, or conditions in which a particular function cannot be used.

 **Reference**

This symbol indicates a reference.

[]

Keys that appear on the machine's panel display.

Keys and buttons that appear on the computer's display.

[]

Keys built into the machine's control panel.

Keys on the computer's keyboard.

This manual contains detailed instructions on configuring the machine as a network printer. Read the section appropriate to your network environment on how to configure the machine correctly.

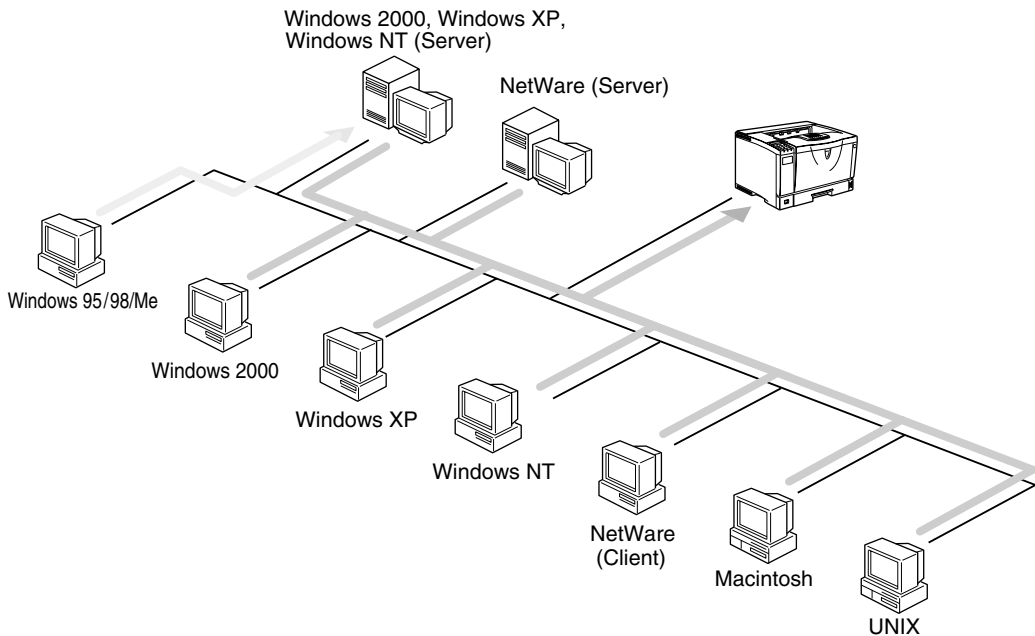

Important

- ❑ The procedures written in this manual assume that you are a network administrator. If you are not, be sure to consult your network administrator before configuration.

Reference

For more information about configuring the Network Interface Board with the control panel, see the Setup Guide.

Features

- Support for 100BASE-TX, 10BASE-T, IP over 1394 and IEEE 802.11b.
- The Network Interface Board is compatible with NetWare ^{*1} (IPX/SPX, TCP/IP), Windows NT 4.0 (TCP/IP, NetBEUI ^{*2}, IPP ^{*3}), Windows 2000 (TCP/IP, NetBEUI ^{*2}, IPP ^{*3}), Windows XP (TCP/IP, IPP ^{*3}), Windows 95/98/Me (TCP/IP, NetBEUI ^{*2}, IPP ^{*3}), UNIX (TCP/IP) and Macintosh (AppleTalk) protocols. This allows you to use the machine in a network that uses different protocols and operating systems.
- A computer used as a dedicated print server is not required because the Network Interface Board can be configured as a NetWare print server.
- The Network Interface Board can connect the machine to the network without requiring its own power supply because the Network Interface Board is installed inside the machine.

*1 If the optional 802.11b Interface Unit has been installed, you cannot use the ad hoc mode.

*2 To use NetBEUI, use the SmartNetMonitor for Client port.

*3 IPP (Internet Printing Protocol) is a protocol for printing via the Internet.

❖ Interface supported protocols

		Interface		
		Ethernet	IEEE 802.11b	IEEE 1394 (IP over 1394)
Protocol	TCP/IP	○	○	○
	NetBEUI	○	○	×
	NetWare	○	○ ^{*1}	×
	AppleTalk	○	○	×

○ means that the protocol is supported.

× means that the protocol is not supported.

*1 If the optional 802.11b Interface Unit has been installed, you cannot use the ad hoc mode.

Setting Up the Machine on a Network

Windows 95/98/Me, Windows 2000/Windows XP, Windows NT 4.0

For setting up the machine as a network printer in Windows 95/98/Me, Windows 2000/Windows XP and Windows NT 4.0 environment.

See p.1 "Windows 95/98/Me Configuration".

See p.13 "Windows 2000 Configuration".

See p.25 "Windows XP Configuration".

See p.37 "Windows NT 4.0 Configuration".

❖ Printing Without a Print Server

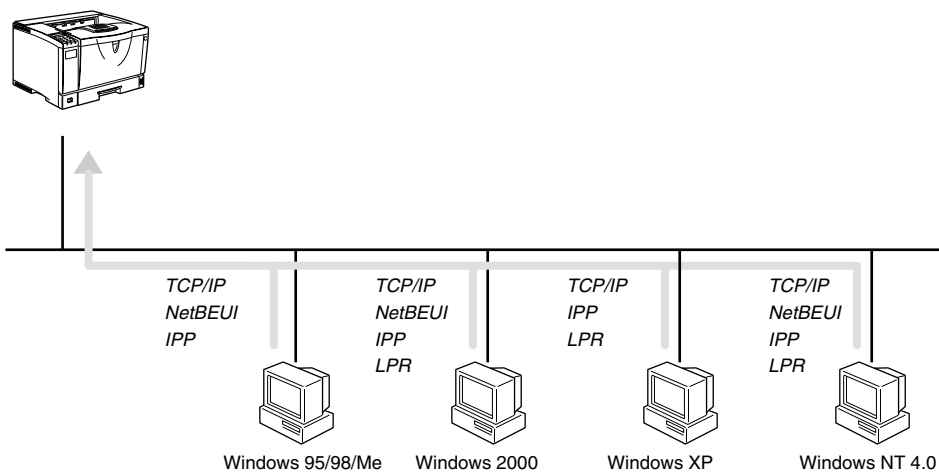

❖ Printing With a Windows 2000, Windows XP or Windows NT Print Server

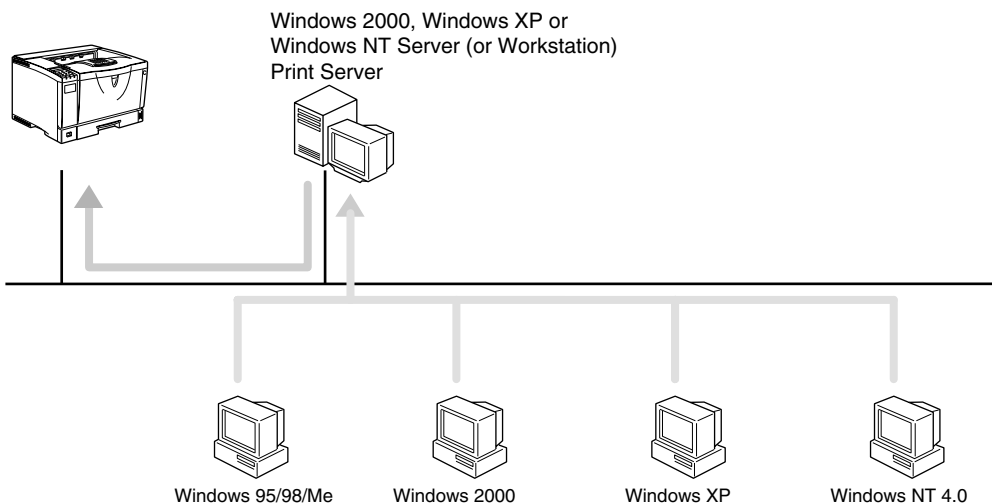

NetWare

For setting up the machine as a network printer in a NetWare environment, see p.49 “NetWare Configuration”. The Network Interface Board allows you to use the machine as either a print server or a remote printer.

For more information about setting up the clients, see the following pages.

- See p.68 “Windows 95/98/Me” .
- See p.69 “Windows 2000” .
- See p.70 “Windows NT 4.0” .

Configuring the machine as a print server

A dedicated NetWare print server is not required because the machine can be configured as a print server.

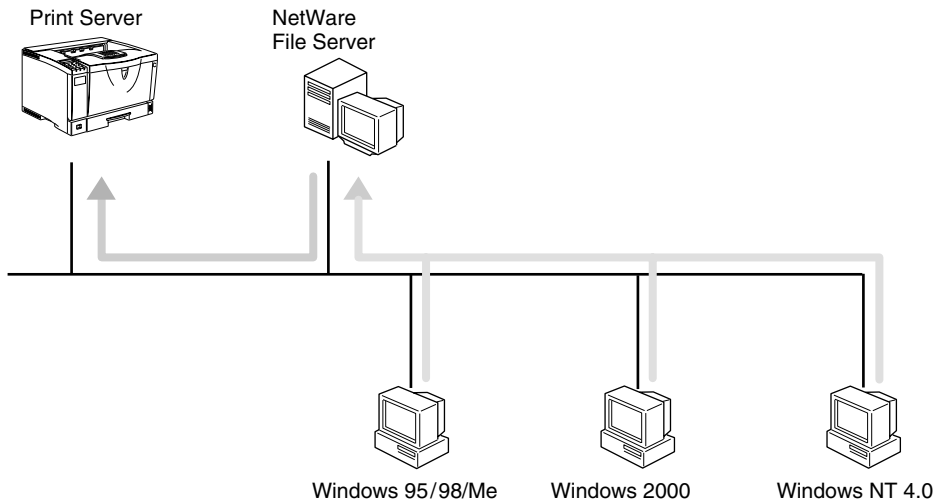

The actual procedures for configuring the machine depend on the NetWare version.

- NetWare 3.x
See p.55 “Setting Up as a Print Server”.
- NetWare 4.x, 5/5.1
See p.61 “Setting Up as a Print Server”.

Configuring the machine as a remote printer

If a dedicated NetWare print server is being used, the machine should be configured as a remote printer.

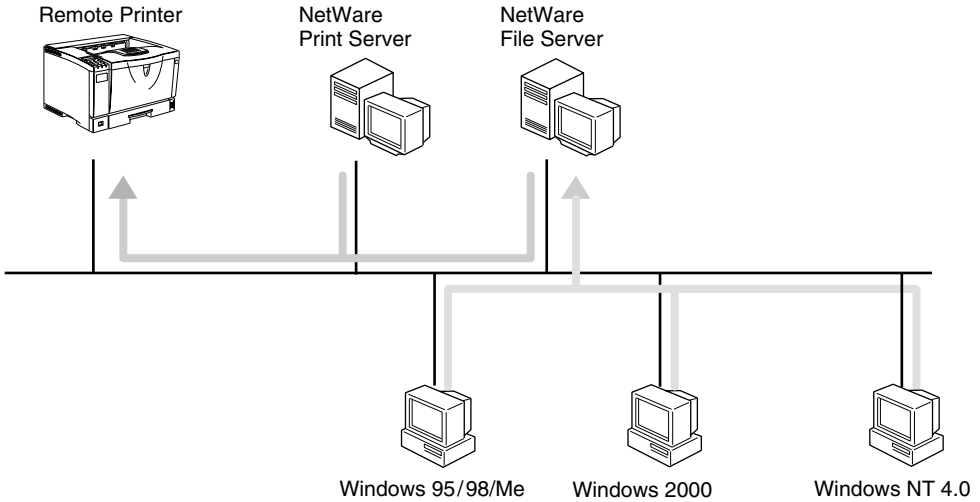

The actual procedures for configuring the machine depend on the NetWare version.

- NetWare 3.x
See p.57 “Setting Up as a Remote Printer”.
- NetWare 4.x, 5/5.1
See p.65 “Setting Up as a Remote Printer”.

Macintosh

For setting up the machine as a network printer in a Macintosh environment, see p.71 “Macintosh Configuration”.

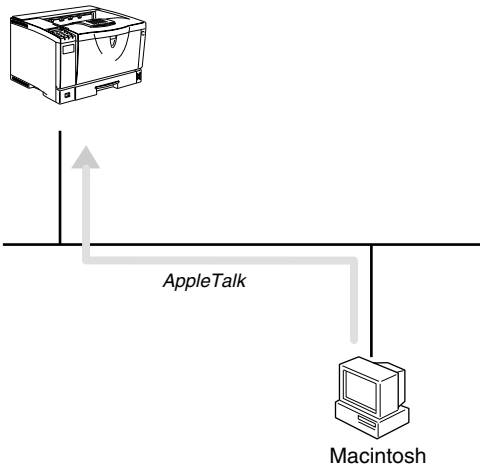

UNIX

Concerning UNIX printing information, please visit our Web site or consult your authorized reseller.

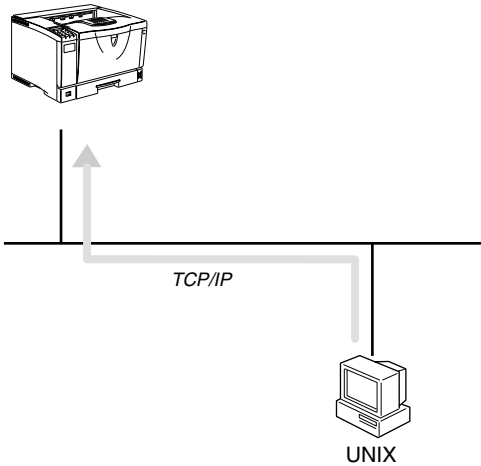

Printing using the IEEE 802.11b Interface

This section describes how to print after installing the optional 802.11b Interface Unit.

There are two methods of using this machine as a network printer with IEEE 802.11b.

❖ **ad hoc mode**

This is the mode for transmitting between each wireless LAN client. You must make the channels the same for each wireless LAN client to transmit using this basic transmitting method which does not require an access point. See p.87 "Using the IEEE 802.11b (Wireless LAN)".

❖ **infrastructure mode**

This is the mode for transmitting via an access point. If an SSID ^{*1} and WEP ^{*2} are set in the access point, you must set the same values for the access point and IEEE 802.11b. By connecting the access point to Ethernet, you can transmit the current network environment. See p.87 “Using the IEEE 802.11b (Wireless LAN)”.

^{*1} This is called a Service Set ID and is used in the connection between the wireless LAN client and the access point. Only a wireless LAN client and an access point that have the same SSID can transmit to each other. (The character strings to be set are in the range ASCII 0x20-0x7e and the SSID is case-sensitive to 32 bytes.)

^{*2} This is used to protect coded wireless data transmission. To transmit between wireless LAN clients and the coded access point, you must set the same WEP key as the printer. (You can set only 10 hexadecimal characters.)

❖ ad hoc mode

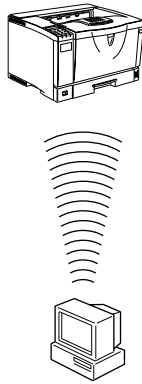

❖ infrastructure mode

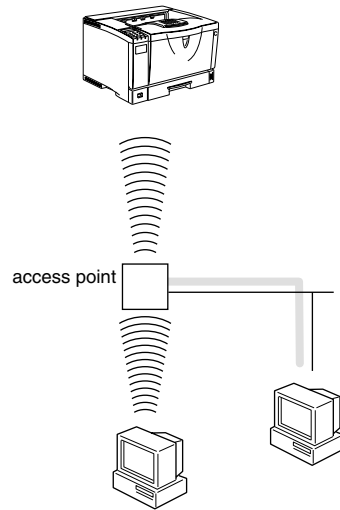

Printing using the IEEE 1394 Interface

This section describes how to print via the IEEE 1394 interface after installing the 1394 Interface Unit Type 4510.

There are two methods of using the machine as a network printer with IEEE 1394.

❖ **SCSI print**

You can print using the SCSI print device provided by Windows 2000 and Windows XP. For more information, see "IEEE 1394 Configuration" in the Setup Guide.

❖ **IP over 1394**

You can print by setting the IP address for this machine and the computer on which Windows XP is installed. For more information, see "IEEE 1394 Configuration" in the Setup Guide and p.25 "Printing with a Standard TCP/IP Port" in the Windows XP Configuration.

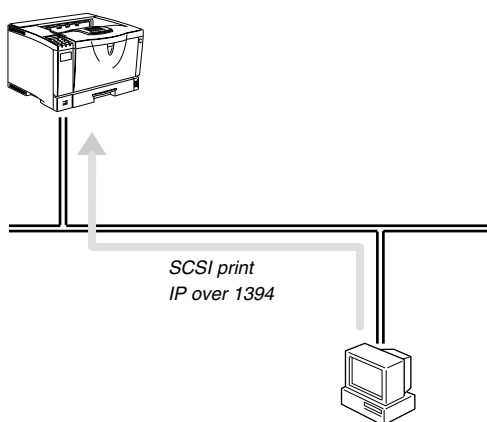

TABLE OF CONTENTS

1. Windows 95/98/Me Configuration

Configuring Windows 95/98/Me	1
Printing without a Print Server.....	1
Printing with a Windows 2000 or Windows NT Print Server	1
Configuring Protocols.....	2
Configuring TCP/IP and IPP for Printing	2
Configuring NetBEUI for Printing	3
Using SmartNetMonitor for Client.....	5
Installing SmartNetMonitor for Client	6
Setting Up the Printer Driver	7
Changing Port Settings	9
Setting Up a Client Computer.....	10

2. Windows 2000 Configuration

Configuring Windows 2000	13
Printing without a Print Server.....	13
Printing with a Standard TCP/IP Port.....	13
Printing with a LPR Port.....	14
Printing with a Windows 2000 or Windows NT Print Server	14
Configuring the Protocols	15
Configuring TCP/IP and IPP for Printing	15
Configuring NetBEUI for Printing	16
Using SmartNetMonitor for Client.....	17
Installing SmartNetMonitor for Client	18
Setting Up the Printer Driver	19
Changing Port Settings	21
Configuring LPR Port Printing	22
Setting Up a Client Computer.....	23

3. Windows XP Configuration

Configuring Windows XP.....	25
Printing without a Print Server.....	25
Printing with a Standard TCP/IP Port.....	25
Printing with a LPR Port.....	26
Printing with a Windows 2000, Windows XP or Windows NT Print Server ...	26
Configuring the Protocols	27
Configuring TCP/IP and IPP for Printing	27
Using SmartNetMonitor for Client.....	29
Installing SmartNetMonitor for Client	30
Setting Up the Printer Driver	31
Changing Port Settings	33

Configuring LPR Port Printing	34
Setting Up a Client Computer.....	35

4. Windows NT 4.0 Configuration

Configuring Windows NT 4.0.....	37
Printing without a Print Server.....	37
Printing with a LPR Port	37
Printing with a Windows 2000 or Windows NT Print Server	37
Configuring the Protocols	38
Configuring TCP/IP and IPP for Printing	38
Configuring NetBEUI for Printing	39
Using SmartNetMonitor for Client.....	41
Installing SmartNetMonitor for Client	42
Setting Up the Printer Driver	43
Changing Port Settings	45
Configuring LPR Port Printing	46
Setting Up a Client Computer.....	47

5. NetWare Configuration

Installing the NIB Setup Tool.....	49
Installing SmartNetMonitor for Admin	50
Running the NIB Setup Tool	50
Quick Setup Using the NIB Setup Tool Wizard.....	51
NetWare 3.x - Advanced Settings	54
Setting Up as a Print Server.....	55
Setting Up as a Remote Printer	57
NetWare 4.x, 5/5.1 - Advanced Settings	60
Setting Up as a Print Server.....	61
Setting Up as a Remote Printer	65
Setting Up a Client Computer.....	68
Windows 95/98/Me.....	68
Windows 2000.....	69
Windows NT 4.0.....	70

6. Macintosh Configuration

Configuring Macintosh	71
Changing to EtherTalk	71
Configuring the Printer	72
Changing the Printer Name.....	72
Changing the Zone.....	72

7. Appendix

Using SmartNetMonitor for Admin	73
Changing the Network Interface Board Configuration.....	74
Managing the User Information.....	75
Configuring the Energy Save Mode	75
Configuring the Network Interface Board with a Web Browser	76
Going to the Top Page	77
Configuring the Network Interface Board Settings	78
Monitoring and Configuring the Printer	81
Changing Names and Comments	81
Displaying the Status of Printer	84
Using the IEEE 802.11b (Wireless LAN)	87
Setting IEEE 802.11b (Wireless LAN).....	87
Using in Ad hoc Mode	88
Using in Infrastructure Mode	89
Confirming the Connection.....	91
Remote Maintenance by telnet.....	92
Using telnet	92
Commands List	93
SNMP	108
Understanding the Displayed Information.....	109
Print Job Information	109
Print Log Information.....	109
Configuring the Network Interface Board	110
Message List.....	113
System Log Information	113
Precautions	119
Connecting a Dial-Up Router to a Network	119
PostScript Printing from Windows.....	120
NetWare Printing.....	120
Using DHCP	121
Configuring a WINS Server	122
When Using the NIB Setup Tool	123
When Using IPP with SmartNetMonitor for Client	123
Specifications	124
INDEX.....	125

1. Windows 95/98/Me Configuration

Configuring Windows 95/98/Me

Printing without a Print Server

The following procedure describes how to configure Windows 95/98/Me to use the machine on a network without a Windows 2000 Server, Windows 2000 Professional, Windows NT Server, Windows NT Workstation, or NetWare based print server.

1 Specify the protocol to use

Consult your network administrator about which of the three protocols is appropriate.

- TCP/IP
- IPP
- NetBEUI

2 Configure the chosen protocol.

- See p.2 "Configuring TCP/IP and IPP for Printing".
- See p.3 "Configuring NetBEUI for Printing".

3 Install the software and set the printer driver port

- Install SmartNetMonitor for Client from the CD-ROM labeled "Printer Drivers and Utilities". For more information about how to install the software and how to specify the printer driver port, see the Setup Guide.

Printing with a Windows 2000 or Windows NT Print Server

See p.10 "Setting Up a Client Computer" for configuring Windows 95/98/Me with a Windows 2000 or Windows NT print server.

Configuring Protocols

1

Configuring TCP/IP and IPP for Printing

These instructions are for configuring the Network Interface Board and Windows 95/98/Me to use the TCP/IP protocol and IPP.

Configuring the machine

Configure the machine to use the TCP/IP protocol.

- Make sure that the TCP/IP protocol is set to active. (The default is active.)
- Assign an IP address and make other settings required for using the TCP/IP protocol.

Reference

For more information about how to make the above settings, see the Setup Guide.

If DHCP is used to assign IP addresses, see p.121 "Using DHCP".

Note

- ❑ After setting the IP address, use the ping command to make sure that it has been set correctly.

① Enable the use of the command prompt as follows:

- On Windows 95 or Windows 98
Click **[Start]**, point to **[Programs]**, and then click **[Command Prompt]**.
- On Windows Me
Click **[Start]**, point to **[Programs]**, point to **[Accessories]**, and then click **[Command Prompt]**.

② Type the following: (Example IP address is 192.168.15.16)

```
C:\> ping 192.168.15.16
```

If the address has been configured correctly, the following message appears.

```
Reply from 192.168.15.16 : bytes=32 time<10ms TTL=32
```

If the address has been configured incorrectly, the following message appears.

```
Request timed out.
```

Configuring a Windows 95/98/Me computer

These steps are for configuring a Windows 95/98/Me computer to use the TCP/IP protocol.

1 Open **[Control Panel]** and then double-click the **[Network]** icon. Make sure that "TCP/IP" is listed in the **[The following network components are installed:]** box on the **[Configuration]** tab.

 **Note**

- If the TCP/IP protocol is not installed, click **[Add]** on the **[Configuration]** tab to install it. For more information about installing the TCP/IP protocol, see Windows 95/98/Me Help.

2 Configure the TCP/IP protocol with the appropriate IP address, subnet mask and other settings.

Check with the network administrator that the settings are correct.

Configuring NetBEUI for Printing

These instructions are for configuring the Network Interface Board and Windows 95/98/Me to use the NetBEUI protocol.

 **Preparation**

To use NetBEUI, use the SmartNetMonitor for Client port.

Configuring the machine

Configure the machine to use the NetBEUI protocol.

- Make sure that the NetBEUI protocol is set to active. (The default is active.)

 **Reference**

For more information about how to make the above settings, see the Setup Guide.

Configuring a Windows 95/98/Me computer

Install the NetBEUI protocol on the Windows 95/98/Me computer and set it as the default protocol.

1 Open [Control Panel], and then double-click the [Network] icon. Make sure that “NetBEUI” is listed in the [The following network components are installed:] box on the [Configuration] tab.

 **Note**

- If the NetBEUI protocol is not installed, click [Add] on the [Configuration] tab to install it. For more information about installing the NetBEUI protocol, see Windows 95/98/Me Help.
- If “NetBEUI →Dial-Up Adaptor” is listed in the [The following network components are installed:] box, select it and click [Remove] to remove the binding.

2 Set the NetBEUI protocol as the default protocol. Click the [Configuration] tab, select “NetBEUI” in the [The following network components are installed:] box, and then click [Properties].

3 Click the [Advanced] tab, select [Set this protocol to be the default protocol], and then click [OK].

4 Click [OK] to close the [Network] dialog box.

5 When the message to restart appears, click [Yes].

Using SmartNetMonitor for Client

SmartNetMonitor for Client is a utility that helps you to use network printers effectively. It is useful in environments where two or more network printers are used. It is recommended that you install SmartNetMonitor for Client to use Parallel Printing and Recovery Printing. For more information about SmartNetMonitor for Client, see SmartNetMonitor for Client Help.

❖ SmartNetMonitor for Client features

- Sends a print job directly to the network printers without using a print server.
- Notifies when a printing error occurs.
- Prints documents using other printers in the printer group when the specified printer is busy (Recovery Printing).
- Equally divides the number of copies to be printed among the selected printers in the printer group (Parallel Printing).

🚨 Important

- ❑ The following must be the same for the specified printer and the printers selected for Recovery Printing or Parallel Printing.
 - Printer models (for Parallel Printing only)
 - Installed options (e.g. Paper tray unit)
 - Size and orientation of paper in each paper tray unit
 - Total memory
 - Installed fonts (including the downloaded fonts)

📝 Note

- ❑ Failure to meet any of the conditions above may result in unexpected print results.

Installing SmartNetMonitor for Client

Install SmartNetMonitor for Client from the CD-ROM labeled “Printer Drivers and Utilities”. For more information about how to install, see the Setup Guide.

After the installation is complete, configure the printer port with SmartNetMonitor for Client. See p.7 “Setting Up the Printer Driver”.

Deleting the port

The following procedure allows you to delete the printer port. If you want to delete the port which is currently used in Windows, switch the port to another such as “FILE”, and then delete it. For more information about SmartNetMonitor for Client, see SmartNetMonitor for Client Help.

- 1** From the [Printers] window, click the icon of the printer which uses SmartNetMonitor for Client to print. On the [File] menu, click [Properties].
 - 2** Click the [Details] tab, and then make sure that the SmartNetMonitor for Client port is shown in the [Print to the following port] box.
Remember the port name because this port should be deleted later.
 - 3** From the [Print to the following port] box, select [FILE].
 - 4** Click [Delete Port].
 - 5** Click the SmartNetMonitor for Client port name as in step **2**, and then click [OK].
The port is deleted.
 - 6** Click [OK] to close the printer properties.
-

Uninstalling SmartNetMonitor for Client

Preparation

Before uninstalling SmartNetMonitor for Client, make sure that:

- The SmartNetMonitor for Client settings dialog box is closed.
- No printer is using the SmartNetMonitor for Client port as a printer port.

- 1** Open [Control Panel], and then double-click the [Add/Remove Programs] icon.
- 2** On the [Install/Uninstall] tab, click [SmartNetMonitor for Client], and then click [Add/Remove].
- 3** After the confirmation message appears, click [Yes].
UninstallShield removes all of the components of SmartNetMonitor for Client.

- 4** After the confirmation message, click **[Yes]**.
- 5** Acknowledge the **[Question]** dialog box.
- 6** When the uninstallation is complete, click **[OK]**.

Setting Up the Printer Driver

The following procedure allows you to configure the printer port to use SmartNetMonitor for Client.

Preparation

The target printer must be turned on before starting the installation process.

- 1** Install the printer driver of the printer you want to use.
- 2** From the **[Printers]** window, click the icon of the printer. On the **[File]** menu, click **[Properties]**.
- 3** Click the **[Details]** tab and click **[Add Port]**.
- 4** Click **[Other]**, click **[SmartNetMonitor]** from the list, and then click **[OK]**.

The **[Select Printer]** dialog box appears .

The displayed items are as follows:

Model Name: The model name of the printer.

Name: The name of the Network Interface Board.

Comment: Additional information about the Network Interface Board.

Address: The IP address of the printer.

- 5** Select the printer.

TCP/IP

- 1** Click the printer you want to use, and then click **[OK]**.

Note

- Printers that respond to an IP broadcast from the computer will be displayed. To print to a printer not listed here, click **[Specify Address]**, and then type the IP address or host name.
- You cannot add an address partially similar to that already used. For example, when "192.168.0.2" is already used, "192.168.0.2xx" cannot be used. Similarly, when "192.168.0.20" is already used, "192.168.0.2" cannot be used.

NetBEUI

1 Click [NetBEUI].

A list of printers that can be printed to by the NetBEUI protocol appears.

2 Click the printer you want to use, and then click [OK]. **Note**

- Printers that respond to a broadcast from the computer will be displayed. To print to a printer not listed here, click [Specify Address], and then type the NetBEUI address. Make sure that the NetBEUI address is on the configuration page. For more information about the printing of the configuration page, see "Printing a Configuration Page" in the Setup Guide. The NetBEUI address appears as "\\RNPxxxx\xxx" on the configuration page. Type the printer's network path name in the form of "%Computer name\Share name". Do not type "\\\" as head characters but "%%".

- You cannot print to printers beyond routers.

IPP

1 Click [IPP].

The IPP setting dialog box appears.

2 To specify the IP address of the printer, type "http://printer's-ip-address/printer" or "ipp://printer's-ip-address/printer" in the [Printer URL] field.

(Example IP address is 192.168.15.16)

`http://192.168.15.16/printer`

`ipp://192.168.15.16/printer`

3 As necessary, type the names to distinguish the printer in [IPP Port Name]. Type a name differing from those of any existing port names.

If you omit this, the address typed in [Printer URL] will be set as the IPP port name.

4 If using a proxy server and IPP user name, click [Detailed Settings] and configure the necessary settings. **Note**

- For more information about these settings, see SmartNetMonitor for Client Help.

6 Click [OK].**7** Make sure that the specified printing port is displayed in the [Print to the following Port] box, and then click [OK].

This completes the settings.

To print, select the specified printer. SmartNetMonitor for Client will now direct print data to the printer automatically.

Changing Port Settings

Follow these steps to change SmartNetMonitor for Client settings, such as Parallel Printing, Recovery Printing, TCP/IP, the proxy server and IPP URL.

 **Note**

- There are no settings for the NetBEUI protocol.
- You can configure Timeout Settings for the TCP/IP protocol.

1 From the [Printers] window, click the printer icon. On the [File] menu, click [Properties].

2 Click the [Details] tab, and then click [Port Settings].

The [Port Settings] dialog box appears.

- For IPP, you can configure User Settings, Proxy Settings and Timeout Settings.

 **Note**

- For more information about these settings, see SmartNetMonitor for Client Help.

Setting Up a Client Computer

1

This section describes the procedures for setting up a client on a network that uses Windows 2000, Windows XP, Windows NT Server or Windows NT Workstation as a print server.

When using a Windows 2000, Windows XP or Windows NT print server, select a shared printer on Windows 2000, Windows XP or Windows NT.

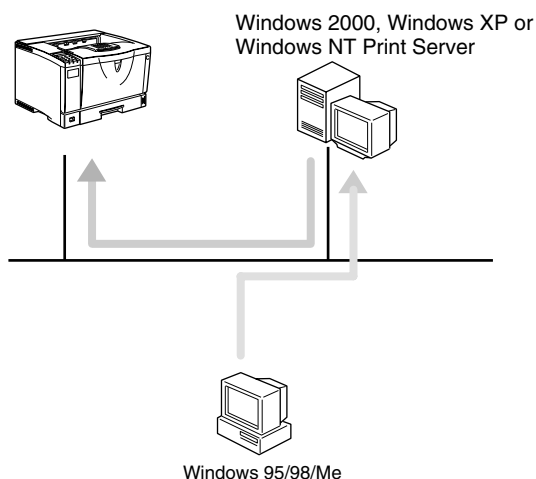

! Limitation

- When using a print server connected to the printer with SmartNetMonitor for Client, you cannot use Recovery Printing and Parallel Printing.

✎ Note

- This section assumes that the client has already been configured to communicate with a Windows 2000, Windows XP or Windows NT print server. Do not begin the following procedure until the client has been set up and configured correctly.

1 Install the printer driver as a local printer.

🔍 Reference

For more information about installing the printer driver, see the Setup Guide.

✎ Note

- Any port can be selected during the installation, however, LPT1 is recommended.

2 Click [Start], point to [Settings], and then click [Printers].

3 Click the icon of the printer you want to use. On the [File] menu, click [Properties].

- 4** Click the [Details] tab, and then click [Add Port].
- 5** Click [Network], and then click [Browse].
- 6** On the network tree, double-click the name of the computer used as the print server.
The printers connected to the network are displayed.
- 7** Click the name of the printer you want to use, and then click [OK].
- 8** Click [OK].
- 9** Make sure that the port name is displayed in the [Print to the following port] box, and then click [OK].

2. Windows 2000 Configuration

Configuring Windows 2000

Printing without a Print Server

The following procedure describes how to configure Windows 2000 to use the machine on a network without a Windows 2000, Windows NT Server, Windows NT Workstation or NetWare based print server.

1 Specify the protocol to use

Consult your network administrator about which of the three protocols is appropriate.

- TCP/IP
- IPP
- NetBEUI

2 Configure the chosen protocol.

- See p.15 "Configuring TCP/IP and IPP for Printing".
- See p.16 "Configuring NetBEUI for Printing".

3 Install the software and set the printer driver port

- Install SmartNetMonitor for Client from the CD-ROM labeled "Printer Drivers and Utilities". For more information about how to install the software and how to specify the printer driver port, see the Setup Guide.

Printing with a Standard TCP/IP Port

Standard TCP/IP port is a standard port of Windows 2000 to enable Peer-to-Peer printing in a network environment.

For more information about Standard TCP/IP port settings, see Windows 2000 Help.

Note

- If a device model selection dialog box appears during the procedure to add the standard TCP/IP port, select "RICOH Network Printer C Model".

Printing with a LPR Port

See p.22 “Configuring LPR Port Printing” for configuring a LPR port in Windows 2000.

Printing with a Windows 2000 or Windows NT Print Server

See p.23 “Setting Up a Client Computer” for configuring Windows 2000 with a Windows 2000 or Windows NT print server.

Configuring the Protocols

Configuring TCP/IP and IPP for Printing

Follow these instructions to configure the Network Interface Board and Windows 2000 to use the TCP/IP protocol and IPP.

Configuring the machine

Configure the machine to use the TCP/IP protocol.

- Make sure that the TCP/IP protocol is set to active. (The default is active.)
- Assign an IP address and make other settings required for using the TCP/IP protocol.

Reference

For more information about how to make the above settings, see the Setup Guide.

If DHCP is used to assign IP addresses, see p.121 “Using DHCP”.

Note

- ❑ After setting the IP address, use the ping command to make sure that it has been set correctly.

① Click **[Start]**, point to **[Programs]**, point to **[Accessories]**, and then click **[Command Prompt]**.

② Type the following: (Example IP address is 192.168.15.16)

```
C:\> ping 192.168.15.16
```

If the address has been configured correctly, the following message appears.

```
Reply from 192.168.15.16 : bytes=32 time<10ms TTL=32
```

If the address has been configured incorrectly, the following message appears.

```
Request timed out.
```

Configuring a Windows 2000 computer

Follow these steps to configure a Windows 2000 computer to use the TCP/IP protocol.

1 Click **[Start]** on the taskbar, point to **[Settings]**, and then click **[Network and Dial-up Connections]**.

2 Click **[Local Area Connection]**. On the **[General]** tab, click **[Properties]**.

- 3** Make sure that the “Internet Protocol (TCP/IP)” is selected in the [Components checked are used by this connection:] box on the [General] tab.

 **Note**

- Select the TCP/IP protocol box if it is not already selected.
- If the TCP/IP protocol is not installed, click [Install] on the [General] tab to install it. For more information about installing the TCP/IP protocol, see Windows 2000 Help.

- 4** Configure the TCP/IP protocol with the appropriate IP address, subnet mask and other settings.

Check with the network administrator that the settings are correct.

Configuring NetBEUI for Printing

Follow these instructions to configure the Network Interface Board and Windows 2000 to use the NetBEUI protocol.

 **Preparation**

To use NetBEUI, use the SmartNetMonitor for Client port.

Configuring the machine

Configure the machine to use the NetBEUI protocol.

- Make sure that the NetBEUI protocol is set to active. (The default is active.)

 **Reference**

For more information about how to make the above settings, see the Setup Guide.

Configuring a Windows 2000 computer

Follow these steps to configure a Windows 2000 computer to use the NetBEUI protocol.

- 1** Click [Start] on the taskbar, point to [Settings], and then click [Network and Dial-up Connections].
- 2** Click [Local Area Connection]. On the [General] tab, click [Properties].
- 3** Make sure that the “NetBEUI Protocol” is selected in the [Components checked are used by this connection:] box on the [General] tab.

 **Note**

- Select the NetBEUI protocol box if it is not already selected.
- If the NetBEUI protocol is not installed, click [Install] on the [General] tab and install it. For more information about installing the NetBEUI protocol, see Windows 2000 Help.

Using SmartNetMonitor for Client

SmartNetMonitor for Client is a utility that helps you to use network printers effectively. It is useful in environments where two or more network printers are used. It is recommended that you install SmartNetMonitor for Client to use Parallel Printing and Recovery Printing. For more information about SmartNetMonitor for Client, see SmartNetMonitor for Client Help.

2

❖ SmartNetMonitor for Client features

- Sends a print job directly to the network printers without using a print server.
- Notifies when a printing error occurs.
- Prints documents using other printers in the printer group when the specified printer is busy (Recovery Printing).
- Equally divides the number of copies to be printed among the selected printers in the printer group (Parallel Printing).

🚨 Important

- ❑ The following must be the same for the specified printer and the printers selected for Recovery Printing or Parallel Printing.
 - Printer models (for Parallel Printing only)
 - Installed options (e.g. Paper tray unit)
 - Size and orientation of paper in each paper tray unit
 - Total memory
 - Installed fonts (including the downloaded fonts)

📝 Note

- ❑ Failure to meet any of the conditions above may result in unexpected print results.

Installing SmartNetMonitor for Client

Install SmartNetMonitor for Client from the CD-ROM labeled "Printer Drivers and Utilities". For more information about how to install, see the Setup Guide.

After the installation is complete, configure the printer port with SmartNetMonitor for Client. See p.19 "Setting Up the Printer Driver".

2

Deleting the port

The following procedure allows you to delete the printer port. If you want to delete the port which is currently used in Windows, switch the port to another such as "FILE", then delete it. For more information about SmartNetMonitor for Client, see SmartNetMonitor for Client Help.

- 1** From the [Printers] window, click the icon of the printer which uses SmartNetMonitor for Client to print. On the [File] menu, click [Properties].
- 2** Click the [Ports] tab, and then make sure that the SmartNetMonitor for Client port is shown in the [Print to the following port(s)] box.
Remember the port name because this port should be deleted later.
- 3** Select the [FILE] check box in the [Port] column.
- 4** Click [OK] to close the Printer Properties.
The port which is currently in use is changed.
- 5** Open the Printer Properties of the same printer.
- 6** Select the [Ports] tab.
- 7** At the [Port] column in the [Print to the following port(s)] dialog box, click to select the SmartNetMonitor for Client port name as in step **2**.
- 8** Click [Delete Port].
- 9** When the confirmation message appears, click [Yes].
The port is deleted.
- 10** Click [Close] to close the Printer Properties.

Uninstalling SmartNetMonitor for Client

Preparation

Before uninstalling SmartNetMonitor for Client, make sure that:

- The port settings dialog box is closed.
- No printer is using the SmartNetMonitor for Client port as a printer port.
- You have performed login with the same user authority as that used to install SmartNetMonitor for Client.

- 1** Open [Control Panel], and then double-click the [Add/Remove Programs] icon.
- 2** Click the [Change or Remove Programs] tab, click [SmartNetMonitor for Client], and then click [Change/Remove].
- 3** After the confirmation message appears, click [Yes].
UninstallShield removes all of the components of SmartNetMonitor for Client.
- 4** After the confirmation message appears, click [Yes].
- 5** Acknowledge the [Remove Shared File?] dialog box.
- 6** When the uninstallation is complete, click [OK].

Setting Up the Printer Driver

The following procedure allows you to configure the printer port to use SmartNetMonitor for Client.

Preparation

The target printer must be turned on before starting the installation process.

- 1** Install the printer driver for the printer you want to use.
- 2** From the [Printers] window, click the icon of the printer. On the [File] menu, click [Properties].
- 3** Click the [Ports] tab and click [Add Port].
- 4** Click [SmartNetMonitor for Client] in the [Available port types:] box, and then click [New Port].

The [Select Printer] dialog box appears and printers on the network are browsed.

The displayed items are as follows:

Model Name: The model name of the printer.

Name: The name of Network Interface Board.

Comment: Additional information about Network Interface Board.

Address: The IP address of the printer.

5 Select the printer.

TCP/IP

- 1 Click the printer you want to use, and then click **[OK]**.

 **Note**

- Printers that respond to an IP broadcast from the computer will be displayed. To print to a printer not listed here, click **[Specify Address]** and then type the IP address or host name.

NetBEUI

- 1 Click **[NetBEUI]**.

A list of printers that can be printed by the NetBEUI protocol appears.

- 2 Click the printer you want to use, and then click **[OK]**.

 **Note**

- Printers that respond to a broadcast from the computer will be displayed. To print to a printer not listed here, click **[Specify Address]** and then type the NetBEUI address. Make sure that the NetBEUI address is on the configuration page. For information about the printing of the configuration page, see "Printing a Configuration Page" in the Setup Guide. The NetBEUI address appears as "\\RNPxxxx\xxx" on the configuration page. Type the printer's network path name in the form of "%Computer name\Share name". Do not type "\\\" as head characters but "%%".

- You cannot print to printers beyond routers.

IPP

- 1 Click **[IPP]**.

The IPP setting dialog box appears.

- 2 To specify the IP address of the printer, type "http://printer's-ip-address/printer" or "ipp://printer's-ip-address/printer" in the **[Printer URL]** field.

(Example IP address is 192.168.15.16)

`http://192.168.15.16/printer`

`ipp://192.168.15.16/printer`

- 3 As necessary, type the names to distinguish the printer in **[IPP Port Name]**. Type a name different from those of any existing port names.

If you omit this, the address entered in **[Printer URL]** will be set as the IPP port name.

- 4 If using a proxy server and IPP user name, click **[Detailed Settings]** and configure the necessary settings.

 **Note**

- For more information about these setting, see SmartNetMonitor for Client Help.

- 6 Click **[OK]**.

- 7 Make sure that the specified printing port is displayed in the **[Print to the following Port(s)]** box, and then click **[Close]**.

This completes the settings.

To print, select the specified printer. SmartNetMonitor for Client will now direct print data to the printer automatically.

Changing Port Settings

Follow the steps to change SmartNetMonitor for Client settings, such as Parallel Printing, Recovery Printing, TCP/IP, the proxy server and IPP URL.

 **Note**

- There are no settings for the NetBEUI protocol.

- 1 From the **[Printers]** window, click the icon of the printer you want to use. On the **[File]** menu, click **[Properties]**.

- 2 Click the **[Ports]** tab, and then click **[Configure Port]**.

The **[Port Settings]** dialog box appears

- For TCP/IP protocol, you can configure Parallel Printing, Recovery Printing and Timeout Settings.
- For IPP, you can configure User Settings, Proxy Settings and Timeout Settings.

 **Note**

- For more information about these settings, see SmartNetMonitor for Client Help.

Configuring LPR Port Printing

This section explains the procedure for printing to a LPR port from Windows 2000.

Note

- The TCP/IP protocols must be installed and configured correctly. For more information about configuring the protocols, see p.15 “Configuring TCP/IP and IPP for Printing”.

1 Click **[Start]**, point to **[Settings]**, and then click **[Printers]**.

The **[Printers]** window appears.

2 Click the icon of the printer you want to use. On the **[File]** menu, click **[Properties]**.

3 Click the **[Ports]** tab and click **[Add Port]**.

4 In the **[Available port types:]** box, click “LPR Port”, and then click **[New Port]**.

Note

- If “LPR Port” does not appear, “Print Services for Unix” has not been installed. For more information about how to install “Print Services for Unix”, see Windows 2000 Help.

5 Type the IP address of the Network Interface Board into the **[Name or address of server providing lpd:]** box.

6 Type “lp” into the **[Name of printer or print queue on that server box:]**, and then click **[OK]**.

7 Click **[Close]**.

8 Make sure that the port name is displayed in the **[Print to the following port(s)]** box and that the check box is selected, and then click **[OK]**.

Setting Up a Client Computer

This section describes the procedures for setting up a client in a network that uses Windows 2000, Windows XP, Windows NT Server or Windows NT Workstation as a print server.

When using a Windows 2000, Windows XP or Windows NT print server, select a shared printer on Windows 2000, Windows XP or Windows NT.

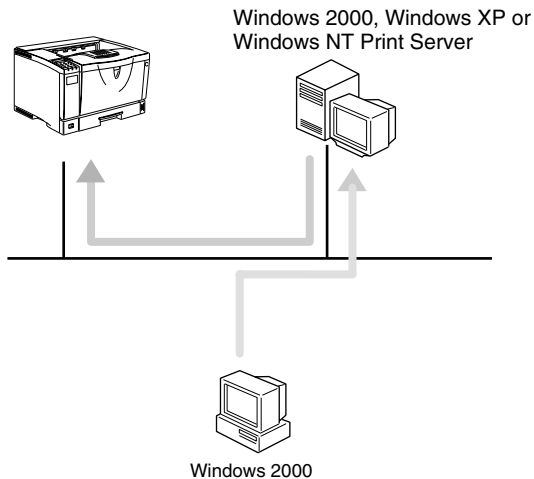

! Limitation

- When using a print server connected to the printer with SmartNetMonitor for Client, you cannot use Recovery Printing and Parallel Printing.

✎ Note

- This section assumes that the client has already been configured to communicate with a Windows 2000, Windows XP or Windows NT print server. Do not begin the following procedure until the client has been set up and configured correctly.

Use the **[Printers]** window to set up the printer.

1 Click **[Start]**, point to **[Settings]** and then click **[Printers]**.

2 Double-click the **[Add Printer]** icon.

This launches the Add Printer Wizard.

3 Click **[Next >]**.

4 Click **[Network printer]**, and then click **[Next >]**.

5 Click **[Next >]**.

6 In the **[Shared printers:]** box, double-click the name of the computer used as a print server.

The printers attached to the network are displayed.

7 Click the printer you want to use, and then click **[Next >]**.

 **Note**

- If the printer driver is not installed in the print server, a message appears. If a driver has been installed on the client, click **[OK]**, and then follow the instructions on the screen.
- There is a Windows 2000 printer driver on the CD-ROM labeled “Printer Drivers and Utilities”.

8 Select whether to use this printer as the default printer, and then click **[Next >]**.

9 After the installation is complete, click **[Finish]**.

The icon of the newly installed printer appears in the **[Printers]** window.

3. Windows XP Configuration

Configuring Windows XP

Printing without a Print Server

The following procedure describes how to configure Windows XP to use the machine on a network without a Windows XP, Windows NT Server, Windows NT Workstation or NetWare based print server.

1 Specify the protocol to use

Consult your network administrator about which of the three protocols is appropriate.

- TCP/IP
- IPP

2 Configure the protocol.

- See p.27 "Configuring TCP/IP and IPP for Printing".

3 Install the software and set the printer driver port

- Install SmartNetMonitor for Client from the CD-ROM labeled "Printer Drivers and Utilities". For more information about how to install the software and how to specify the printer driver port, see the Setup Guide.

Printing with a Standard TCP/IP Port

Standard TCP/IP port is a standard port of Windows XP to enable Peer-to-Peer printing in a network environment.

For more information about Standard TCP/IP port settings, see Windows XP Help.

Note

- If a device model selection dialog box appears during the procedure to add the standard TCP/IP port, select "RICOH Network Printer C Model".

Printing with a LPR Port

See p.34 “Configuring LPR Port Printing” for configuring a LPR port in Windows XP.

Printing with a Windows 2000, Windows XP or Windows NT Print Server

See p.35 “Setting Up a Client Computer” for configuring Windows XP with a Windows 2000, Windows XP or Windows NT print server.

Configuring the Protocols

Configuring TCP/IP and IPP for Printing

Follow these instructions to configure the Network Interface Board and Windows XP to use the TCP/IP protocol and IPP.

Configuring the machine

Configure the machine to use the TCP/IP protocol.

- Make sure that the TCP/IP protocol is set to active. (The default is active.)
- Assign an IP address and make other settings required for using the TCP/IP protocol.

Reference

For more information about how to make the above settings, see the Setup Guide.

If DHCP is used to assign IP addresses, see p.121 “Using DHCP”.

To use the IP over 1394, see the Setup Guide.

Note

- ❑ After setting the IP address, use the ping command to make sure that it has been set correctly.

① Click **[Start]**, point to **[All Programs]**, point to **[Accessories]**, and then click **[Command Prompt]**.

② Type the following: (Example IP address is 192.168.15.16)

```
C:\> ping 192.168.15.16
```

If the address has been configured correctly, the following message appears.

```
Reply from 192.168.15.16 : bytes=32 time<10ms TTL=32
```

If the address has been configured incorrectly, the following message appears.

```
Request timed out.
```

Configuring a Windows XP computer

Follow these steps to configure a Windows XP computer to use the TCP/IP protocol.

1 Click **[Start]** on the taskbar, point to **[Control Panel]**, and then click **[Network and Internet Connections]**.

2 Click **[Local Area Connection]**. On the **[General]** tab, click **[Properties]**.

 **Note**

With the IP over 1394, click **[1394 Connection]**.

3 Make sure that the “Internet Protocol (TCP/IP)” is selected in the **[This connection uses the following items:]** box on the **[General]** tab.

 **Note**

Select the TCP/IP protocol box if it is not already selected.

If the TCP/IP protocol is not installed, click **[Install...]** on the **[General]** tab to install it. For more information about installing the TCP/IP protocol, see Windows XP Help.

4 Configure the TCP/IP protocol with the appropriate IP address, subnet mask and other settings.

Check with the network administrator that the settings are correct.

Using SmartNetMonitor for Client

SmartNetMonitor for Client is a utility that helps you to use network printers effectively. It is useful in environments where two or more network printers are used. It is recommended that you install SmartNetMonitor for Client to use Parallel Printing and Recovery Printing. For more information about SmartNetMonitor for Client, see SmartNetMonitor for Client Help.

❖ SmartNetMonitor for Client features

- Sends a print job directly to the network printers without using a print server.
- Notifies when a printing error occurs.
- Prints documents using other printers in the printer group when the specified printer is busy (Recovery Printing).
- Equally divides the number of copies to be printed among the selected printers in the printer group (Parallel Printing).

🚨 Important

- ❑ The following must be the same for the specified printer and the printers selected for Recovery Printing or Parallel Printing.
 - Printer models (for Parallel Printing only)
 - Installed options (e.g. Paper tray unit)
 - Size and orientation of paper in each paper tray unit
 - Total memory
 - Installed fonts (including the downloaded fonts)

📝 Note

- ❑ Failure to meet any of the conditions above may result in unexpected print results.

🔍 Reference

For more information about how to use SmartNetMonitor for Client, see the "readmeXP.txt" file included on the CD-ROM labeled "Operating Instructions" (If the CD-ROM drive is D, the folder will be "D:\Network\Netmon\Client\Disk1").

Installing SmartNetMonitor for Client

Install SmartNetMonitor for Client from the CD-ROM labeled “Printer Drivers and Utilities”. For more information about how to install, see the Setup Guide.

After the installation is complete, configure the printer port with SmartNetMonitor for Client. See p.31 “Setting Up the Printer Driver”.

Deleting the port

3

The following procedure allows you to delete the printer port. If you want to delete the port which is currently used in Windows, switch the port to another such as “FILE”, then delete it. For more information about SmartNetMonitor for Client, see SmartNetMonitor for Client Help.

- 1** From the [Printers] window, click the icon of the printer which uses SmartNetMonitor for Client to print. On the [File] menu, click [Properties].
- 2** Click the [Ports] tab, and then make sure that the SmartNetMonitor for Client port is shown in the [Print to the following port(s)] box.
Remember the port name because this port should be deleted later.
- 3** Select the [FILE] check box in the [Port] column.
- 4** Click [OK] to close the Printer Properties.
The port which is currently in use is changed.
- 5** Open the Printer Properties of the same printer.
- 6** Select the [Ports] tab.
- 7** At the [Port] column in the [Print to the following port(s)] dialog box, click to select the SmartNetMonitor for Client port name as in step **2**.
- 8** Click [Delete Port].
- 9** When the confirmation message appears, click [Yes].
The port is deleted.
- 10** Click [Close] to close the Printer Properties.

Uninstalling SmartNetMonitor for Client

Preparation

Before uninstalling SmartNetMonitor for Client, make sure that:

- The port settings dialog box is closed.
- No printer is using the SmartNetMonitor for Client port as a printer port.
- You have performed login with the same user authority as that used to install SmartNetMonitor for Client.

- 1** Open [Control Panel], and then double-click the [Add/Remove Programs] icon.
- 2** Click the [Add or Remove Programs] category, click [SmartNetMonitor for Client], and then click [Change/Remove].
- 3** After the confirmation message appears, click [Yes].
UninstallShield removes all of the components of SmartNetMonitor for Client.
- 4** After the confirmation message appears, click [Yes].
- 5** Acknowledge the [Remove Shared File?] dialog box.
- 6** When the uninstallation is complete, click [OK].

Setting Up the Printer Driver

The following procedure allows you to configure the printer port to use SmartNetMonitor for Client.

Preparation

The target printer must be turned on before starting the installation process.

- 1** Install the printer driver for the printer you want to use.
- 2** From the [Printers] window, click the icon of the printer. On the [File] menu, click [Properties].
- 3** Click the [Ports] tab and click [Add Port].
- 4** Click [SmartNetMonitor for Client] in the [Available port types:] box, and then click [New Port].

The [Select Printer] dialog box appears and printers on the network are browsed.

The displayed items are as follows:

Model Name: The model name of the printer.

Name: The name of Network Interface Board.

Comment: Additional information about Network Interface Board.

Address: The IP address of the printer.

5 Select the printer.

TCP/IP

- 1 Click the printer you want to use, and then click **[OK]**.

 **Note**

- Printers that respond to an IP broadcast from the computer will be displayed. To print to a printer not listed here, click **[Specify Address]** and then type the IP address or host name.

IPP

- 1 Click **[IPP]**.

The IPP setting dialog box appears.

- 2 To specify the IP address of the printer, type "**http://printer's-ip-address/printer**" or "**ipp://printer's-ip-address/printer**" in the **[Printer URL]** field.

(Example IP address is 192.168.15.16)

http://192.168.15.16/printer

ipp://192.168.15.16/printer

- 3 As necessary, type the names to distinguish the printer in **[IPP Port Name]**. Type a name different from those of any existing port names.

If you omit this, the address entered in **[Printer URL]** will be set as the IPP port name.

- 4 If using a proxy server and IPP user name, click **[Detailed Settings]** and configure the necessary settings.

 **Note**

- For more information about these setting, see SmartNetMonitor for Client Help.

- 6 Click **[OK]**.

- 7 Make sure that the specified printing port is displayed in the **[Print to the following Port(s)]** box, and then click **[Close]**.

This completes the settings.

To print, select the specified printer. SmartNetMonitor for Client will now direct print data to the printer automatically.

Changing Port Settings

Follow the steps to change SmartNetMonitor for Client settings, such as Parallel Printing, Recovery Printing, TCP/IP, the proxy server and IPP URL.

 **Note**

- There are no settings for the NetBEUI protocol.

1 Access the **[Printers and Faxes]** window from **[Start]** on the taskbar.

2 Click the **[Ports]** tab, and then click **[Configure Port]**.

The **[Port Settings]** dialog box appears

- For TCP/IP protocol, you can configure Parallel Printing, Recovery Printing and Timeout Settings.
- For IPP, you can configure User Settings, Proxy Settings and Timeout Settings.

 **Note**

- For more information about these settings, see SmartNetMonitor for Client Help.

Configuring LPR Port Printing

This section explains the procedure for printing to a LPR port from Windows XP.

Note

- The TCP/IP protocols must be installed and configured correctly. For more information about configuring the protocols, see p.27 “Configuring TCP/IP and IPP for Printing”.

3

- 1** Access the [Printers and Faxes] window from [Start] on the taskbar.
- 2** Click the icon of the printer you want to use. On the [File] menu, click [Properties].
- 3** Click the [Ports] tab and click [Add Port].
- 4** In the [Available port types:] box, click “LPR Port”, and then click [New Port].

Note

- If “LPR Port” does not appear, “Print Services for Unix” has not been installed. For more information about how to install “Print Services for Unix”, see Windows XP Help.

- 5** Type the IP address of the Network Interface Board into the [Name or address of server providing lpd:] box.
- 6** Type “lp” into the [Name of printer or print queue on that server:], and then click [OK].
- 7** Click [Close].
- 8** Make sure that the port name is displayed in the [Print to the following port(s)] box and that the check box is selected, and then click [OK].

Setting Up a Client Computer

This section describes the procedures for setting up a client in a network that uses Windows 2000, Windows XP, Windows NT Server or Windows NT Workstation as a print server.

When using a Windows 2000, Windows XP or Windows NT print server, select a shared printer on Windows 2000, Windows XP or Windows NT.

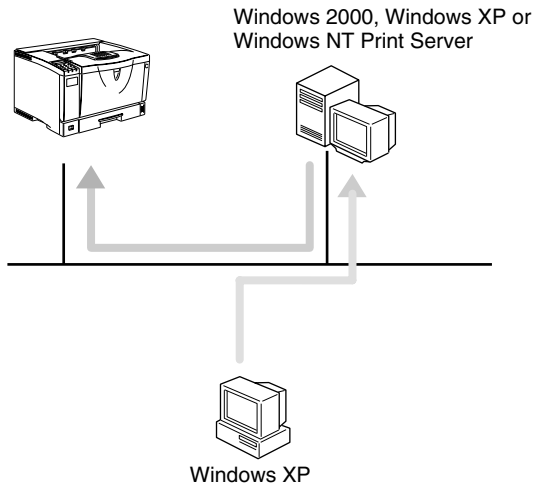

3

! Limitation

- When using a print server connected to the printer with SmartNetMonitor for Client, you cannot use Recovery Printing and Parallel Printing.

✎ Note

- This section assumes that the client has already been configured to communicate with a Windows 2000, Windows XP or Windows NT print server. Do not begin the following procedure until the client has been set up and configured correctly.

Use the **[Printers]** window to set up the printer.

- 1** Access the **[Printers and Faxes]** window from **[Start]** on the taskbar.
- 2** Click **[Add Printer]** in the **Printer Tasks** category.
This launches the Add Printer Wizard.
- 3** Click **[Next >]**.
- 4** Click **[[A network printer, or a printer attached to another computer.]**, and then click **[Next >]**.
- 5** Click **[Next >]**.

6 In the **[Shared printers:]** box, double-click the name of the computer used as a print server.

The printers attached to the network are displayed.

7 Click the printer you want to use, and then click **[Next >]**.

 **Note**

If the printer driver is not installed in the print server, a message appears. If a driver has been installed on the client, click **[OK]**, and then follow the instructions on the screen.

There is a Windows XP printer driver on the CD-ROM labeled "Printer Drivers and Utilities".

8 Select whether to use this printer as the default printer, and then click **[Next >]**.

9 After the installation is complete, click **[Finish]**.

The icon of the newly installed printer appears in the **[Printers]** window.

4. Windows NT 4.0 Configuration

Configuring Windows NT 4.0

Printing without a Print Server

The following procedure describes how to configure Windows NT 4.0 to use the machine on a network without a Windows 2000, Windows NT Server, Windows NT Workstation or NetWare based print server.

1 Specify the protocol to use

Consult your network administrator about which of the three protocols is appropriate.

- TCP/IP
- IPP
- NetBEUI

2 Configure the chosen protocol.

- See p.38 "Configuring TCP/IP and IPP for Printing".
- See p.39 "Configuring NetBEUI for Printing".

3 Install the software and set the printer driver port

- Install SmartNetMonitor for Client from the CD-ROM labeled "Printer Drivers and Utilities". For more information about how to install the software and how to specify the printer driver port, see the Setup Guide.

Printing with a LPR Port

See p.46 "Configuring LPR Port Printing" for how to configure a LPR port in Windows NT 4.0.

Printing with a Windows 2000 or Windows NT Print Server

See p.47 "Setting Up a Client Computer" for configuring Windows NT 4.0 with a Windows 2000 or Windows NT print server.

Configuring the Protocols

Configuring TCP/IP and IPP for Printing

These instructions are for configuring the Network Interface Board and Windows NT to use the TCP/IP protocol and IPP.

Configuring the machine

Configure the machine to use the TCP/IP protocol.

- Make sure that the TCP/IP protocol is set to active. (The default is active.)
- Assign an IP address and make other settings required for using the TCP/IP protocol.

Reference

For more information about how to make the above settings, see the Setup Guide.

If DHCP is used to assign IP addresses, see p.121 "Using DHCP".

Note

- After setting the IP address, use the ping command to make sure that it has been correctly set.

① Click **[Start]**, point to **[Programs]**, and then click **[Command Prompt]**.

② Type the following: (Example IP address is 192.168.15.16)

```
C:\> ping 192.168.15.16
```

If the address has been configured correctly, the following message appears.

```
Reply from 192.168.15.16 : bytes=32 time<10ms TTL=32
```

If the address has been configured incorrectly, the following message appears.

```
Request timed out.
```

Configuring a Windows NT computer

These steps are for configuring a Windows NT computer to use the TCP/IP protocol.

- 1** Open **[Control Panel]**, and then double-click the **[Network]** icon. Make sure that "TCP/IP Protocol" is listed in the **[Network protocols]** box on the **[Protocols]** tab.

Note

- If the TCP/IP protocol is not installed, click **[Add]** on the **[Protocols]** tab to install it. For more information about installing the TCP/IP protocol, see Windows NT Help.

- 2** Configure the TCP/IP protocols with the appropriate IP address, subnet mask and other settings.

Check with the network administrator that the settings are correct.

- 3** Click the **[Services]** tab, and then make sure that “Microsoft TCP/IP Printing” is installed.

If “Microsoft TCP/IP Printing” is not installed, click **[Add]** on the **[Services]** tab, to install it. For more information about installing and configuring network services, see Windows NT Help.

Configuring NetBEUI for Printing

These instructions are for configuring the Network Interface Board and Windows NT to use the NetBEUI protocol.

Preparation

To use NetBEUI, use the SmartNetMonitor for Client port.

Configuring the machine

Configure the machine to use the NetBEUI protocol.

- Make sure that the NetBEUI protocol is set to active. (The default is active.)

Reference

For more information about how to make the above settings, see the Setup Guide.

Configuring a Windows NT computer

Install the NetBEUI protocol on the Windows NT computer, and then change the LAN adapter number (Lana Number).

- 1** Open **[Control Panel]**, and then double-click the **[Network]** icon. Make sure that “NetBEUI Protocol” is listed in the **[Network Protocols]** box on the **[Protocols]** tab.

Note

- If the NetBEUI protocol is not installed, click **[Add]** on the **[Protocols]** tab to install it. For more information about installing the NetBEUI protocol, see Windows NT Help.

- 2** Change the Lana Number. Click the **[Services]** tab, click “NetBIOS Interface” in the **[Services]** tab, and then click **[Properties]**.

- 3** Click the Lana Number corresponding the Nbf protocol of the **[Network Route]** headline, and then click **[Edit]**.

4 Type "0" as the Lana Number.

 **Note**

- If the other protocol's Lana Number is configured with "0", you must change the Lana Number a number other than "0".

5 Click [OK].

6 Click [Close], and then close the [Network] dialog box.

7 After checking the message to restart, click [Yes].

 **Note**

- After you change the Lana Number, you must restart the computer.

Using SmartNetMonitor for Client

SmartNetMonitor for Client is a utility that helps you to use network printers effectively. It is useful in environments where two or more network printers are used. It is recommended that you install SmartNetMonitor for Client to use Parallel Printing and Recovery Printing. For more information about SmartNetMonitor for Client, see SmartNetMonitor for Client Help.

❖ SmartNetMonitor for Client features

- Sends a print job directly to the network printers without using a print server.
- Notifies when a printing error occurs.
- Prints documents using other printers in the printer group when the specified printer is busy (Recovery Printing).
- Equally divides the number of copies to be printed among the selected printers in the printer group (Parallel Printing).

🚨 Important

- ❑ The following must be the same for the specified printer and the printers selected for Recovery Printing or Parallel Printing.
 - Printer models (for Parallel Printing only)
 - Installed options (e.g. Paper tray unit)
 - Size and orientation of paper in each paper tray unit
 - Total memory
 - Installed fonts (including the downloaded fonts)

📝 Note

- ❑ Failure to meet any of the conditions above may result in unexpected print results.

⚠️ Limitation

- ❑ On a computer that is used as a print server, do not use the features such as Parallel Printing, Recovery Printing and Notify. For more information about turning off these features, see SmartNetMonitor for Client Help.

Installing SmartNetMonitor for Client

Install SmartNetMonitor for Client from the CD-ROM labeled “Printer Drivers and Utilities”. For more information about how to install, see the Setup Guide.

After the installation is complete, configure the printer port with SmartNetMonitor for Client. See p.43 “Setting Up the Printer Driver”.

Deleting the port

The following procedure allows you to delete the printer port. If you want to delete the port which is currently used in Windows, switch the port to another such as “FILE”, then delete it. For more information about SmartNetMonitor for Client, see SmartNetMonitor for Client Help.

- 1** From the [Printers] window, click the icon of the printer which uses SmartNetMonitor for Client to print. On the [File] menu, click [Properties].
 - 2** Click the [Ports] tab, and then make sure that the SmartNetMonitor for Client port is shown in the [Print to the following port] box.
Remember the port name because this port should be deleted later.
 - 3** From the [Print to the following port] box, select [FILE].
 - 4** Click [Apply].
The port which is currently in use is changed.
 - 5** Click [Delete Port].
 - 6** After the confirmation message appears, click [Yes].
The port is deleted.
 - 7** Click [OK] to close the printer properties.
-

Uninstalling SmartNetMonitor for Client

Preparation

Before uninstalling SmartNetMonitor for Client, make sure that:

- The port settings dialog box is closed.
- No printer is using the SmartNetMonitor for Client port as a printer port.
- You have performed login with the same user authority as that used to install SmartNetMonitor for Client.

- 1** Open [Control Panel], and then double-click the [Add/Remove Programs] icon.
- 2** On the [Install/Uninstall] tab, click [SmartNetMonitor for Client] and click [Add/Remove].

- 3** After the confirmation message appears, click **[Yes]**.
UninstallShield removes all of the components of SmartNetMonitor for Client.
- 4** After a confirmation message appears, click **[Yes]**.
- 5** Acknowledge the **[Remove Shared File?]** dialog box.
- 6** When the uninstallation is complete, click **[OK]**.

Setting Up the Printer Driver

The following procedure allows you to configure the printer port to use SmartNetMonitor for Client.

Preparation

The target printer must be turned on before starting the installation process.

- 1** Install the printer driver of the printer you want to use.
- 2** From the **[Printers]** window, click the icon of the printer. On the **[File]** menu, click **[Properties]**.
- 3** Click the **[Ports]** tab and click **[Add Port]**.
- 4** Click **[SmartNetMonitor]** from the list, and then click **[New Port...]**.
The **[Select Printer]** dialog box appears .
The displayed items are as follows:
Model Name: The model name of the printer.
Name: The name of the Network Interface Board.
Comment: Additional information about the Network Interface Board.
Address: The IP address of the printer.
- 5** Select the printer.

TCP/IP

- 1** Click the printer you want to use, and then click **[OK]**.

Note

- Printers that respond to an IP broadcast from the computer will be displayed. To print to a printer not listed here, click **[Specify Address]**, and then type the IP address or host name.

NetBEUI

1 Click **[NetBEUI]**.

A list of printers that can be printed by the NetBEUI protocol appears.

2 Click the printer you want to use, and then click **[OK]**. **Note**

- Printers that respond to a broadcast from the computer will be displayed. To print to a printer not listed here, click **[Specify Address]** and then type the NetBEUI address. Make sure that the NetBEUI address is on the configuration page. For information about the printing of the configuration page, see "Printing a Configuration Page" in the Setup Guide. The NetBEUI address appears as "\\RNPxxxx\xxx" on the configuration page. Type the printer's network path name in the form of "%Computer name\Share name". Do not type "\\" as head characters but "%".

- You cannot print to printers beyond routers.

IPP

1 Click **[IPP]**.

The IPP setting dialog box appears.

2 To specify the IP address of the printer, type "http://printer's-ip-address/printer" or "ipp://printer's-ip-address/printer" in the **[Printer URL]** field.

(Example IP address is 192.168.15.16)

`http://192.168.15.16/printer`

`ipp://192.168.15.16/printer`

3 As necessary, type the names to distinguish the printer in **[IPP Port Name]**. Type a name different from those of any existing port names.

If you omit this, the address entered in **[Printer URL]** will be set as the IPP port name.

4 If using a proxy server and IPP user name, click **[Detailed Settings]** and configure the necessary settings. **Note**

- For more information about these setting, see SmartNetMonitor for Client Help.

6 Click **[OK]**.**7** Make sure that the specified printing port is displayed in the **[Print to the following Port]** box, and then click **[OK]**.

This completes the settings.

To print, select the printer specified here. SmartNetMonitor for Client will now direct print data to the printer automatically.

Changing Port Settings

Follow the steps to change SmartNetMonitor for Client settings, such as Parallel Printing, Recovery Printing, TCP/IP, the proxy server settings and IPP URL.

 **Note**

There are no settings for the NetBEUI protocol.

1 From the **[Printers]** window, click the icon of the printer you want to use. On the **[File]** menu, click **[Properties]**.

2 Click the **[Ports]** tab, and then click **[Port Configuration]**.

The **[Port Settings]** dialog box appears

- For TCP/IP protocol, you can configure Recovery Printing, Parallel Printing and Timeout Settings.
- For IPP, you can configure User Settings, Proxy Settings and Timeout Settings.

 **Note**

For more information about these settings, see SmartNetMonitor for Client Help.

Configuring LPR Port Printing

This section explains the procedure for printing to a LPR port from Windows NT.

Note

- The following procedure assumes that the printer drivers have already been installed. This is the procedure to change the printer port to LPR.
- The TCP/IP protocols must be installed and configured correctly. For more information about configuring the protocol, see p.38 "Configuring TCP/IP and IPP for Printing".

1 Click [Start], point to [Settings], and then click [Printers].

2 Click the icon of the printer you want to use. On the [File] menu, click [Properties].

3 Click the [Ports] tab, and then click [Add Port].

4 In the [Available Printer Ports] box, click "LPR Port", and then click [New Port].

Note

- If "LPR Port" does not appear, "Microsoft TCP/IP Printing" has not been installed.

5 Type the IP address of the Network Interface Board into the [Name or address of server providing lpd] box.

6 Type "lp" into the [Name of printer or print queue on that server] box, and then click [OK].

7 Click [Close].

8 Make sure that the port name is displayed in the [Print to the following port(s)] box and the check box is selected, and then click [OK].

Setting Up a Client Computer

This section describes the procedures for setting up a client in a network that uses Windows 2000, Windows XP, Windows NT Server or Windows NT Workstation as a print server.

When using a Windows 2000, Windows XP or Windows NT print server, select a shared printer on Windows 2000, Windows XP or Windows NT.

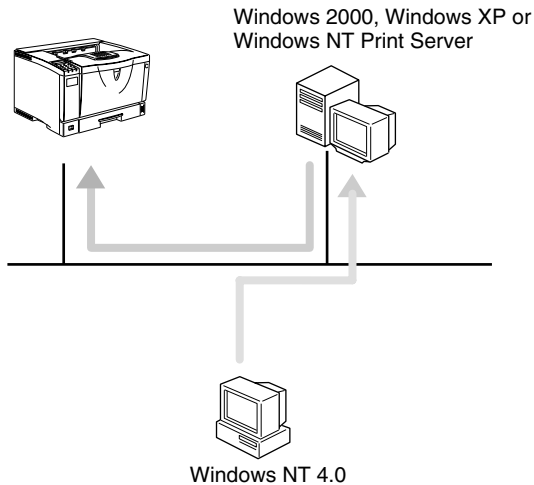

! Limitation

- When using a print server connected to the printer with SmartNetMonitor for Client, you cannot use Recovery Printing and Parallel Printing.

✎ Note

- This section assumes that the client has already been configured to communicate with a Windows 2000, Windows XP or Windows NT print server. Do not begin the following procedure until the client has been set up and configured correctly.

Use the **[Printers]** window to set up the printer.

1 Click **[Start]**, point to **[Settings]**, and then click **[Printers]**.

2 Double-click the **[Add Printer]** icon.

This launches the Add Printer Wizard.

3 Click **[Network printer server]** and click **[Next >]**.

4 In the **[Shared Printers]** box, double-click the name of the computer used as a print server.

The printers attached to the network are displayed.

5 Click the printer you want to use and click **[OK]**.

 **Note**

- If the printer driver is not installed in the print server, a message appears. If a driver has been installed on the client, click **[OK]** and follow the instructions on the screen.
- There is a Windows NT printer driver on the CD-ROM labeled "Printer Drivers and Utilities".

6 Select if you want to use this printer as the default printer, and then click **[Next >]**.

7 After the installation is complete, click **[Finish]**.

The icon of the newly installed printer appears in the **[Printers]** window.

5. NetWare Configuration

This chapter describes how to configure the machine to use as a print server or a remote printer in a NetWare environment.

Note

- NetWare must be set to active using the machine's control panel. For more information about how to set it, see the Setup Guide.

Installing the NIB Setup Tool

A utility called the NIB Setup Tool is provided to configure the machine to work in a network environment. This section describes how to install the SmartNetMonitor for Admin, and how to run the NIB Setup Tool.

Limitation

- The NIB Setup Tool is supported to work with the following operating systems.
 - Microsoft Windows 95/98/Me
 - Microsoft Windows 2000
 - Microsoft Windows NT 4.0

SmartNetMonitor for Admin

Using a printer in a NetWare environment, configure the NetWare printing environment by using SmartNetMonitor for Admin.

Note

- If you configure the NetWare printing environment by using SmartNetMonitor for Admin under the following environments, NetWare Client provided by Novell is required.
 - NDS mode in Windows 95/98
 - NDS or Bindary mode in Windows 2000/Windows NT 4.0

Printers listed by SmartNetMonitor for Admin

SmartNetMonitor for Admin displays a list of printers, which are connected to the network.

If you cannot find out the printer from the displayed list, refer to the configuration page printed from the printer. For more information about printing a configuration page, see the Setup Guide.

Installing SmartNetMonitor for Admin

Install SmartNetMonitor for Admin on your computer. For the installation procedure, see the Setup Guide.

After installing SmartNetMonitor for Admin, see one of the following sections:

- To configure the Network Interface Board as a NetWare print server for the first time, see p.51 “Quick Setup Using the NIB Setup Tool Wizard”.
- To use this computer with NetWare 3.x as a print server, see p.54 “NetWare 3.x - Advanced Settings”.
- To use this computer with NetWare 3.x as a remote printer, see p.54 “NetWare 3.x - Advanced Settings”.
- To use this computer with NetWare 4.x, 5 or 5.1 as a print server, see p.60 “NetWare 4.x, 5/5.1 - Advanced Settings”.
- To use this computer with NetWare 4.x, 5 or 5.1 as a print server, see p.60 “NetWare 4.x, 5/5.1 - Advanced Settings”.

5

Running the NIB Setup Tool

- 1** Click [Start], point to [Programs], and then click [NIB Setup Tool] in the [SmartNetMonitor for Admin] program folder.

Quick Setup Using the NIB Setup Tool Wizard

With the NIB Setup Tool, you can easily set up a NetWare printing environment.

Reference

For more information about installing the NIB Setup Tool, see p.49 “Installing the NIB Setup Tool”.

You can select **[Wizard]** or **[Property Sheet]** as an installation method.

When you configure the Network Interface Board for the first time, use the Wizard method.

If you want to use the Property Sheet method, see p.54 “NetWare 3.x - Advanced Settings” or p.60 “NetWare 4.x, 5/5.1 - Advanced Settings”.

Note

- This section assumes that NetWare is functional and that the necessary environment for NetWare Print Services is available.
- If you configure the Network Interface Board in a NetWare environment using the NIB Setup Tool, you should install the client software released from Novell in the following cases.
 - Windows 95/98/Me in NDS mode configuration
 - Windows NT 4.0 in NDS mode configuration
 - Windows NT 4.0 in Bindery mode configuration
 - Windows 2000 in NDS mode configuration
 - Windows 2000 in Bindery mode configuration

1 Log on to the Netware file server or the NDS tree as an Admin or Admin equivalent.

2 Run the NIB Setup Tool.

Reference

See p.50 “Running the NIB Setup Tool” .

3 Click **[Wizard]** and click **[OK]**.

The **[NIB Setup Tool - Network board list]** dialog box of the Network Interface Board appears.

4 Click **[IPX protocol]**.

5 Click to select the IPX address of the Network Interface Board you are configuring, and then click **[Next >]**.

Note

- If you do not know which Network Interface Board you are configuring, print a network configuration page to check the MAC address (Network address).

6 Make sure that the MAC address and IPX address are correct, and then click **[Finish]**.

7 Type the print server name into the **[Device Name]** box, and then click **[Next >]**.

The default setting is “RDP_” followed by the 6 digit serial number. We recommend that you change it to something that is easier to remember or something based on the structure of the network.

8 In a dialog box for selecting a network environment, click to select the **[NetWare]** check box and click to clear the **[TCP/IP]** check box.

9 Click **[Next >]**.

A dialog box for configuring the NetWare environment appears.

10 Select **[Bindery]** when printing under Bindery mode, or select **[NDS]** when printing under NDS mode.

When you are using NetWare version 4.x, you should select **[NDS]**.

11 If you selected **[Bindery]**, type into the **[File Server Name:]** box the name of the file server in which a print server is to be created.

After clicking **[Browse]**, you can select a file server among those listed in the **[Browse]** dialog box.

12 If you selected **[NDS]**, type into the **[Tree:]** box the name of the NDS tree in which the print server is created, and then type the context into the **[Context:]** box.

Clicking **[Browse]**, you can select an NDS tree and an NDS context among those listed in the **[Browse]** dialog boxes.

As a context, object names are typed from a lower object and divided by a period. For example, if you want to create a print server into NET under DS, type “NET.DS”.



13 Click **[Next >]**.

14 Type the name of the printer into the **[Printer Name]** box, and the name of the print queue into the **[Print Queue Name]** box.

The default setting for Printer Name is “Print Server Name” followed by “_1” and for Print Queue Name is “Print Server Name” followed by “_Q” (quotation marks are not included). You can change them if necessary.

15 If you have selected the NDS mode, type the volume of the print queue into the **[Queue Volume]** box.

Clicking **[Browse]**, you can select one of those shown in the **[Browse]** dialog box.

16 Click **[Next >]**.

A dialog box to acknowledge the printing environment appears.

17 After checking the environment, click **[Next >]**.

If you want to change the settings, click **[< Back]**, and then make the settings again.

Clicking **[Next >]**, the NIB Setup Tool automatically creates the Print Server, the Printer, and the Print Queue in the NetWare network.

18 After the confirmation dialog box appears, select **[Quit]** and click **[Finish]** to exit the NIB Setup Tool.

NetWare 3.x - Advanced Settings

The actual procedures for configuring the machine vary depending on whether the Network Interface Board is configured as a print server or as a remote printer. This section describes how to configure the machine in the NetWare 3.x environment.

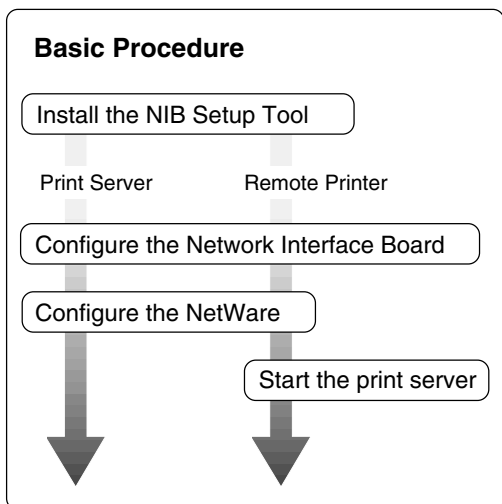

5

Preparation

The following procedures use the Property Sheet method in configuring the Network Interface Board. If you configure the Network Interface Board as a NetWare print server for the first time, we recommend you use the Wizard method. See p.51 "Quick Setup Using the NIB Setup Tool Wizard".

Note

- ❑ This section assumes NetWare is functional and that the necessary environment for the NetWare Print Service is available.

Setting Up as a Print Server

1 Log on to the file server as a Supervisor or a Supervisor equivalent.

2 Run the NIB Setup Tool.

 **Reference**

See p.50 “Running the NIB Setup Tool” .

3 Click [Property Sheet] and click [OK].

The [NIB Setup Tool - Network board list] dialog box of the Network Interface Board appears.

4 Click [IPX protocol].

5 Click the IPX address of the Network Interface Board which is to be configured, and then click [Next >].

 **Note**

If you do not know which Network Interface Board you are configuring, see the network configuration page to check the MAC address (Network Address).

6 Make sure that the MAC address and IPX address are correct, and then click [Finish].

The [NIB Setup Tool] window appears.

7 Click [Configure].

The property sheet appears.

8 Click the [General] tab, and then type the name of the print server into the [Device Name] box.

9 Click the [NetWare] tab, and then make the following settings.

1 Select [Bindery].

2 In the [File Server Name:] box, type the name of the file server in which a print server is to be created.

Click [Browse] to select a file server among those listed in the [Browse] dialog box.

3 Click [OK] to close the property sheet.

4 After the confirmation dialog box appears, click [OK].

10 On the [NIB] menu, click [Exit] to exit the NIB Setup Tool.

11 Type “PCONSOLE” from the command prompt.

F :> PCONSOLE

12 Create a print queue as follows: **Note**

If you use a currently defined print queue, go to step **13**.

- 1** From the [Available Options] menu, select [Print Queue Information], and then press the [ENTER] key.
- 2** Press the [INSERT] key, and then type a print queue name.
- 3** Press the [ESC] key to return to the [Available Options] menu.

13 Create a printer as follows:

- 1** From the [Available Options] menu, select [Print Server Information], and then press the [ENTER] key.
- 2** To create a new print server, press the [INSERT] key, and then type a print server name.

If you use a currently defined print server, select one of the print servers shown in the [Print Server] list.

 **Important**

Use the same name as that specified in the NIB Setup Tool. (Step **8**).

- 3** From the [Print Server Information] menu, select [Print Server Configuration].
- 4** From the [Print Server Configuration] menu, select [Printer Configuration].
- 5** Select the printer which is indicated as "Not Installed".
- 6** If you want to change the name of the printer, type a new name.

A name "Printer x" is assigned to the printer. "x" stands for the number of the selected printer.

- 7** For type, select [Remote Other/Unknown].
The IRQ, Buffer size, Starting form, and Queue service mode are automatically configured.
- 8** Press the [ESC] key, and then click [Yes] in the confirmation dialog box.
- 9** Press the [ESC] key to return to the [Print Server Configuration] menu.

14 Assign print queues to the created printer as follows:

- 1** From the [Print Server Configuration] menu, select [Queues Serviced By Printer].
- 2** Select the printer created in step **13**.
- 3** Press the [INSERT] key to select a queue serviced by the printer.

 **Note**

You can select more than one queue at a time.

- 4** Follow the instructions on the screen to make other necessary settings.

When you have finished the previous steps, make sure that the queues are assigned.

- 15 Press the **[ESC]** key until “Exit?” appears, and then select **[Yes]** to exit PCONSOLE.

 **Note**

- To make sure that the printer is correctly configured, type the following from the command prompt.

F : > USERLIST

- If the printer works as configured, the name of the print server appears as an attached user.

Setting Up as a Remote Printer

- 1 Log on to the file server as a Supervisor or a Supervisor equivalent.

- 2 Run the NIB Setup Tool.

 **Reference**

See p.50 “Running the NIB Setup Tool” .

- 3 Click **[Property Sheet]** and click **[OK]**.

The **[NIB Setup Tool - Network board list]** dialog box of the Network Interface Board appears.

- 4 Click **[IPX protocol]**.

- 5 Click the IPX address of the Network Interface Board which is to be configured, and then click **[Next >]**.

 **Note**

- If you do not know which Network Interface Board you are configuring, see a network configuration page to check the MAC address (Network Address).

- 6 Make sure that the MAC address and IPX address are correct, and then click **[Finish]**.

The **[NIB Setup Tool]** window appears.

- 7 Click **[Configure]**.

The property sheet appears.

- 8 Click the **[General]** tab, and then type the name of the print server into the **[Device Name]** box.

- 9 Click the **[NetWare]** tab, and then make the following settings.

- 1 In the **[Print Server Name]** box, type the name of the print server.

- ② In the [File Server Name] box, type the name of the file server in which a print server is to be created.

Clicking [Browse], you can select a file server among those listed in the [Browse] dialog box.

- ③ In the [Print Server Operation Mode] group, click [As Remote Printer].
- ④ In the [Remote Printer No.] box, type the printer number.

Important

Use the same printer number as that to be created in the printer server.

- ⑤ Click [OK] to close the property sheet.
- ⑥ After the confirmation dialog box appears, click [OK].

- ⑩ On the [NIB] menu, click [Exit] to exit the NIB Setup Tool.

- ⑪ Type "PCONSOLE" from the command prompt.

```
F:> PCONSOLE
```

- ⑫ Create a print queue as follows:

Note

If you use a currently defined print queue, go to step ⑩.

- ① From the [Available Options] menu, select [Print Queue Information], and then press the [ENTER] key.
- ② Press the [INSERT] key, and then type a print queue name.
- ③ Press the [ESC] key to return to the [Available Options] menu.

- ⑬ Create a printer as follows.

- ① From the [Available Options] menu, select [Print Server Information], and then press the [ENTER] key.
- ② To create a new print server, press the [INSERT] key, and then type a print server name.

If you use a currently defined print server, select one of the print servers shown in the [Print Server] list.

Important

Use the same name as that specified in the NIB Setup Tool. (Step ③).

- ③ From the [Print Server Information] menu, select [Print Server Configuration].
- ④ From the [Print Server Configuration] menu, select [Printer Configuration].
- ⑤ Select the printer which is indicated as "Not Installed".

Important

Use the same number as that specified as Remote Printer No. using the NIB Setup Tool. (Step ②-④).

6 Type a new name, if you change the name of the printer.

A name "Printer x" is assigned to the printer. x stands for the number of the selected printer.

7 Select [Remote Parallel, LPT1] for type.

The IRQ, Buffer size, Starting form, and Queue service mode are automatically configured.

8 Press the [ESC] key, and then click [Yes] in the confirmation dialog box.**9 Press the [ESC] key to return to [Print Server Configuration Menu].****14 Assign print queues to the created printer as follows:****1 From [Print Server Configuration Menu], select [Queues Serviced By Printer].****2 Select the printer created in step 13.****3 Press the [INSERT] key to select a queue serviced by the printer.** **Note**

You can select more than one queue at a time.

4 Follow the instructions on the screen to make other necessary settings.

When you have finished the above steps, make sure that the queues are assigned.

15 Press the [ESC] key until "Exit?" appears, and then select [Yes] to exit PCONSOLE.**16 Start the print server by typing the following from the console of the NetWare Server.**

If it is running, restart it after exiting it.

❖ To exit

```
CAREE: unload pserver
```

❖ To start

```
CAREE: load pserver print_server_name
```

 **Note**

If the printer works as configured, "Waiting for job" appears.

NetWare 4.x, 5/5.1 - Advanced Settings

The actual procedures for configuring the machine vary depending on whether the Network Interface Board is configured as a print server or as a remote printer. This section describes how to configure it in the NetWare 4.x, 5/5.1 environment.

❖ To use NetWare 5/5.1

- If you use Pure IP, configure the machine to use the TCP/IP protocol. For more information about how to make the settings, see the Setup Guide.

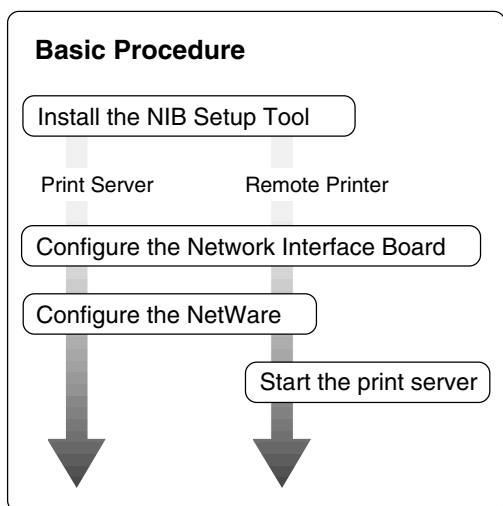

5

📁 Preparation

The following procedures use the Property Sheet method in configuring the Network Interface Board. If you configure the Network Interface Board as a NetWare print server for the first time, we recommend you use the Wizard method. See p.51 “Quick Setup Using the NIB Setup Tool Wizard”.

📌 Note

- ❑ This section assumes NetWare is functional and that the necessary environment for the NetWare Print Service is available.
- ❑ You should install the client software released from Novell in Windows before running the NIB Setup Tool for configuring in NDS mode or using Windows NT 4.0.

Setting Up as a Print Server

Important

- You can set up the print server using the NDS or Bindery mode in NetWare 4.x, 5/5.1. The following procedure is for setting up the print server using the NDS mode in NetWare 4.1. When you set up the print server using the Bindery mode, use the NIB Setup Tool Wizard. See p.51 “Quick Setup Using the NIB Setup Tool Wizard”.

Note

- If you use Pure IP in NetWare 5/5.1, follow the procedure on p.63 “Using Pure IP in the NetWare 5/5.1 environment”.

1 Log on to the file server as an Admin or an Admin equivalent.

2 Run the NIB Setup Tool.

Reference

See p.50 “Running the NIB Setup Tool”.

3 Click [Property Sheet] and click [OK].

4 Click [IPX protocol].

5 Click the IPX address of the Network Interface Board which is to be configured, and then click [Next >].

Note

- If you do not know which Network Interface Board you are configuring, see the network configuration page to check the MAC address (Network Address).

6 Make sure that the MAC address and IPX address are correct, and then click [Finish].

The [NIB Setup Tool] window appears.

7 Click [Configure].

The property sheet appears.

8 Click the [General] tab, and then type the name of the print server into the [Device Name] box.

9 Click the [NetWare] tab, and then make the following settings.

1 In the [Print Sever Name:] box, type the name of the print sever.

2 In the [File Sever Name:] box, type the name of the file sever in which a print server is to be created.

Clicking [Browse], you can select a file server among those listed in the [Browse] dialog box.

- 3 In the **[NDS Context:]** box, type the context in which the print server is to be created.

Clicking **[Browse]**, you can select a context among those listed in the **[Browse]** dialog box.

As a context, object names are typed from a lower object and divided by a period. For example, if you want to create a print server into NET under DS, type "NET.DS".



- 4 Click **[OK]** to close the property sheet.
 - 5 After the confirmation dialog box appears, click **[OK]**.
- 5**
- 10 On the **[NIB]** menu, click **[Exit]** to exit the NIB Setup Tool.
 - 11 From Windows, run NWAdmin.

Reference

For more information about NWAdmin, see the documentation that comes with the NetWare.

- 12 Create a print queue as follows:

- 1 Select the container object the print queue is located in among those in the directory tree, and then click **[Create]** on the **[Object]** menu.
- 2 In the **[Class of new object]** box, click "Print Queue", and then click **[OK]**.
- 3 In the **[Print Queue name]** box, type the name of the print queue.
- 4 In the **[Print Queue volume]** box, click the **[Browse]** button.
- 5 In the **[Available objects]** box, click the volume in which the print queue is created, and then click **[OK]**.
- 6 After checking the settings, click **[Create]**.

- 13 Create a printer as follows:

- 1 Select the container object the printer is located in, and then click **[Create]** on the **[Object]** menu.
- 2 In the **[Class of new object]** box, click "Printer", and then click **[OK]**. When you are using NetWare 5/5.1, click "Printer (Non NDPS)".
- 3 In the **[Printer name]** box, type the name of the printer.
- 4 Select the **[Define additional properties]** check box, and then click **[Create]**.

- 14** Assign print queues to the created printer as follows:
- 1 Click [Assignments], and then click [Add] in the [Assignments] group.
 - 2 In the [Available objects] box, click the queue created in step 12, and then click [OK].
 - 3 Click [Configuration], and in the [Printer type] box, select [Parallel] using the drop-down menu, and then click [Communication].
 - 4 Click [Manual load] in the [Communication type] group, and then click [OK].
 - 5 After checking the settings, click [OK].

- 15** Create a print server as follows:
- 1 Select the context specified using the NIB Setup Tool (step 9-1), and on the [Object] menu, click [Create].
 - 2 In the [Class of new object] box, click "Print Server", and then click [OK]. When you are using NetWare 5/5.1, click "Print Server (Non NDPS)".
 - 3 In the [Print Server name] box, type the name of the print server.

Important

- Use the same name as that specified using the NIB Setup Tool. (Step 8)
- 4 Select the [Define additional properties] check box, and then click [Create].
- 16** Assign the printer to the created print server as follows.
- 1 Click [Assignments], and then click [Add] in the [Assignments] group.
 - 2 In the [Available objects] box, click the printer created in step 13, and then click [OK].
 - 3 After checking the settings, click [OK].

Note

- If the printer works as configured, the name of the print server appears as an attached user.

Using Pure IP in the NetWare 5/5.1 environment

- 1 Log on to the file server as an Admin or an Admin equivalent.
- 2 Run the NIB Setup Tool.

Reference

See p.50 "Running the NIB Setup Tool".

- 3 Click [Property Sheet] and click [OK].
The [Network board list] dialog box appears.
- 4 Click [TCP/IP protocol].

- 5** Click the IP address of the Network Interface Board which is to be configured, and then click **[Next >]**.

 **Note**

- If you do not know which Network Interface Board you are configuring, see the network configuration page to check the MAC address (Network Address).

- 6** Make sure that the MAC address and IP address are correct, and then click **[Finish]**.

The **[NIB Setup Tool]** window appears.

- 7** Click **[Configure]**.

The property sheet appears.

- 8** Click the **[General]** tab, and then type the name of the print server into the **[Device Name:]** box.

- 9** Click the **[NetWare]** tab, and then make the following settings.

- 1** In the **[Print Server Name:]** box, type the name of the print server.
- 2** In the **[File Server Name:]** box, type the name of the file server in which a print server is to be created.

Clicking **[Browse]**, you can select a file server among those listed in the **[Browse File Server]** dialog box.

- 3** In the **[NDS Context:]** box, type the context of the print server.

Clicking **[Browse]**, you can select an NDS tree and an NDS context among those listed in the **[Browse Context]** dialog box.

As a context, object names are typed from a lower object and divided by a period. For example, if you want to create a print server into NET under DS, type "NET.DS".



- 4** In the **[Print Server Operation Mode]** group, click **[As Print Server]**.
- 5** Click **[OK]** to close the property sheet.
- 6** After the confirmation dialog box appears, click **[OK]**.

- 10** On the **[NIB]** menu, click **[Exit]** to exit the NIB Setup Tool.

After this step, go to step **11** on p.61 "Setting Up as a Print Server".

Setting Up as a Remote Printer

1 Log on to the file server as an Admin or an Admin equivalent.

2 Run the NIB Setup Tool.

 **Reference**

See p.50 “Running the NIB Setup Tool” .

3 Click [Property Sheet] and click [OK].

The [NIB Setup Tool - Network board list] dialog box of the Network Interface Board appears.

4 Click [IPX protocol].

5 Click the IPX address of the Network Interface Board which is to be configured, and then click [Next >].

 **Note**

If you do not know which Network Interface Board you are configuring, see the network configuration page to check the MAC address (Network Address).

6 Make sure that the MAC address and IPX address are correct, and then click [Finish].

The [NIB Setup Tool] window appears.

7 Click [Configure].

The property sheet appears.

8 Click the [General] tab, and then type the name of the print server into the [Device Name] box.

9 Click the [NetWare] tab, and then make the following settings.

1 In the [Print Server Name:] box, type the name of the print server.

2 In the [File Server Name:] box, type the name of the file server in which a print server is to be created.

Clicking [Browse], you can select a file server among those listed in the [Browse] dialog box.

- 3 In the [NDS Context:] box, type the context in which the print server is to be created.

Clicking [Browse], you can select a context among those listed in the [Browse] dialog box.

As a context, object names are typed from a lower level object and divided by a period. For example, if you want to create a print server into NET under DS, type "NET.DS".



- 4 In the [Print Server Operation Mode] group, click [As Remote Printer].
- 5 In the [Remote Printer No.] box, type the number of the printer.

Important

- Use the same number as that of the printer to be created in the print server.

- 6 Click [OK] to close the property sheet.
- 7 After the confirmation dialog box appears, click [OK].

- 10 On the [NIB] menu, click [Exit] to exit the NIB Setup Tool.

- 11 From Windows, run NWAdmin.

Reference

For more information about NWAdmin, see the documentation that comes with the NetWare.

- 12 Create a print queue as follows:

- 1 Select the container object the print queue is located in among those in the directory tree, and then click [Create] on the [Object] menu.
- 2 In the [Class of new object] box, click "Print Queue", and then click [OK].
- 3 In the [Print Queue name] box, type the name of the print queue.
- 4 In the [Print Queue Volume] box, click [Browse] button.
- 5 In the [Available objects] box, click the volume in which the print queue is created, and then click [OK].
- 6 After checking the settings, click [Create].

- 13 Create a printer as follows:

- 1 Select the container object the printer is located in, and then click [Create] in the [Object] menu.
- 2 In the [Class of new object] box, click "Printer", and then click [OK]. When you are using NetWare 5/5.1, click "Printer (Non NDPS)".

- ③ In the [Printer name] box, type the name of the printer.
- ④ Select the [Define additional properties] check box, and then click [Create].

14 Assign print queues to the created printer as follows:

- ① Click [Assignments], and then click [Add] in the [Assignments] group.
- ② In the [Available objects] box, click the queue created in step ⑫, and then click [OK].
- ③ Click [Configuration], and in the [Printer type] box, select [Parallel] using the drop-down menu, and then click [Communication].
- ④ Click [Manual load] in the [Communication type] group, and then click [OK].
- ⑤ After checking the settings, click [OK].

15 Create a print server as follows:

- ① Select the context specified using the NIB Setup Tool (Step ⑨-⑩), and on the [Object] menu, click [Create].
- ② In the [Class of new object] box, click "Print Server", and then click [OK]. When you are using NetWare 5/5.1, click "Print Server (Non NDPS)".
- ③ In the [Print Server name] box, type the name of the print server.

Important

- Use the same name as that specified using the NIB Setup Tool. (Step ⑧).

- ④ Select the [Define additional properties] check box, and then click [Create].

16 Assign the printer to the created print server as follows.

- ① Click [Assignments], and then click [Add] in the [Assignments] group.
- ② In the [Available objects] box, click the queue created in the step ⑬, and then click [OK].
- ③ In the [Printers] group, click the printer assigned in step ②, and then click [Printer Number].
- ④ Type the printer number and click [OK].

Important

- Use the same number as that specified as Remote Printer No. using the NIB Setup Tool. (Step ⑨-⑤).

- ⑤ After checking the settings, click [OK].

17 Start the print server by typing the following from the console of the NetWare Server.

If it is running, restart it after exiting it.

❖ To exit

```
CAREE: unload pserver
```

❖ To start

```
CAREE: load pserver print_server_name
```

Setting Up a Client Computer

This section describes how to set up a client computer when using a NetWare print server.

Note

- Use the version of Novell Client provided with your operating system or the latest version.
- This section assumes that the client has NetWare client applications installed and is correctly configured to communicate with a NetWare print server. If not, install the necessary applications before starting the setting up procedure.

Windows 95/98/Me

Follow the procedure to set up a Windows 95/98/Me client.

Preparation

Log on to the NetWare file server before starting the following procedure.

1 Install the printer driver you want to use as “Local printer”.

Reference

For more information about installing the printer driver, see the Setup Guide.

Note

- Any port can be selected during the installation, however, LPT1 is recommended.

2 Click [Start], point to [Settings], and then click [Printers].

3 In the [Printers] window, click the icon of the printer you want to use.

4 On the [File] menu, click [Properties].

5 Click the [Details] tab, and then click [Add Port].

6 Click [Network] and click [Browse].

7 On the network tree, double-click the name of the file server.

The queues are displayed.

8 Click the queue you want to print, and then click [OK].

9 Click [OK].

In the [Print to the following port] box, a network path to the printer appears.

- 10** Click **[OK]** to close the **Printer Properties**, and again, open it.
- 11** Click the **[Printer Settings]** tab.
- 12** Select to clear the **[Form feed]** and **[Enable banner]** check boxes.

 **Note**

- You should not select these boxes because they should be specified using the printer driver. If they are selected, the printer might not print correctly.

When using the PostScript printer driver

Follow these steps to set up for the PostScript printer driver.

- 1** Click the **[PostScript]** tab.
 - 2** Click **[Advanced]**.
 - 3** Click to clear the **[Send CTRL+D before job]** and **[Send CTRL+D after job]** check boxes.
- 13** Click **[OK]** to close the **Printer Properties**.

Windows 2000

Follow the procedure to set up a Windows 2000 client.

 **Preparation**

Log on to the NetWare file server before starting the following procedure.

- 1** Double-click the **[My Network Places]** icon on the desktop and navigate to the queue you want to use, and then double-click it.
The printers dialog box appears.
- 2** Click **[No]**.
- 3** Close all the applications that are currently running.
- 4** Insert the CD-ROM labeled "Printer Drivers and Utilities" into the CD-ROM drive.
If the setup menu starts automatically, you can go to the next step. If not, see the Setup Guide.
- 5** The **[Printer Installation]** dialog box appears.
- 6** From the **[Port]** list, select the queue you selected in step **1**, and then click **[Next >]**.
- 7** Follow the instructions on the screen to complete the installation of the printer driver.

Windows NT 4.0

Follow the procedure to set up a Windows NT 4.0 client.

Preparation

Log on to the NetWare file server before starting the following procedure.

- 1** Double-click the **[Network Neighborhood]** icon on the desktop and navigate to the queue you want to use, and then double-click it.

The **[Printers]** dialog box appears.

- 2** Click **[No]**.

- 3** Close all the applications that are currently running.

- 4** Insert the CD-ROM labeled “Printer Drivers and Utilities” into the CD-ROM drive.

5

If the setup menu starts automatically, you can go to the next step. If not, see the Setup Guide.

- 5** The **[Printer Installation]** dialog box appears.

- 6** From the **[Port]** list, select the queue you selected in step **1**, and then click **[Next >]**.

- 7** Follow the instructions on the screen to complete the installation of the printer driver.

6. Macintosh Configuration

Configuring Macintosh

This section describes how to configure a Macintosh computer to use EtherTalk. The actual procedures to configure a Macintosh may vary depending on the version of the Mac OS. The following procedure describes how to configure Mac OS 9.1. If you are not using Mac OS 9.1, see the manual that comes with your version of Mac OS for more information.

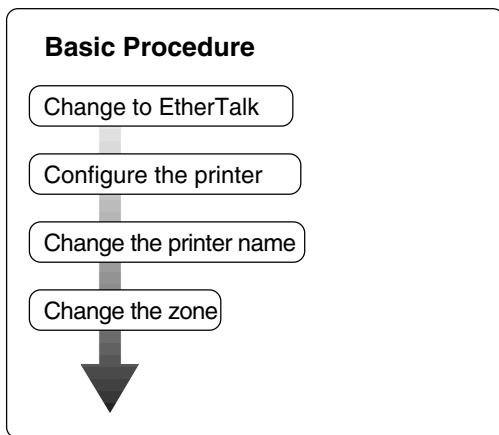

! Limitation

- The required version of Mac OS is 8.6 or later. (Mac OS X Classic environment is supported.)

Changing to EtherTalk

The following procedure is for configuring a Macintosh computer to use EtherTalk.

🔍 Reference

For more information about installing the software required for EtherTalk, see the Macintosh manuals.

- 1** Open [Control Panel], and then double-click the [AppleTalk] icon.
- 2** From the [Connect via:] pop-up menu, select "Ethernet".
- 3** If you change zones, select a name from the [Current zone:] pop-up menu.
- 4** Close the [AppleTalk] control panels.
- 5** Restart the Macintosh.

Configuring the Printer

Use the control panel to activate the EtherTalk protocol. (The default is active.)

Reference

For more information about configuration, see the Setup Guide.

Changing the Printer Name

If the network has several similar model printers, the names will be the same. Printers that have the same name will have their names slightly changed in the Chooser. For example, three printers named “printer” will appear in the chooser as “printer0”, “printer1” and “printer2”.

To change the printer name in the Macintosh EtherTalk environment, use the Printer Utility for Mac included on the CD-ROM labeled “Printer Drivers and Utilities”.

Changing the Zone

To change the zone configuration in the Macintosh EtherTalk environment, use the Printer Utility for Mac included on the CD-ROM labeled “Printer Drivers and Utilities”.

Reference

For more information about using Printer Utilities for Mac, see PostScript 3 Supplement provided as a PDF file on the CD-ROM labeled “Operating Instructions”.

Using SmartNetMonitor for Admin

Using SmartNetMonitor for Admin, you can not only monitor the status of network printers, but also allows you to change the configurations of the Network Interface Board using the TCP/IP protocol or IPX/SPX protocol.

SmartNetMonitor for Admin is equipped with the following functions.

- Limits the settings to be done from the control panel, and disables changes to be made to some of the items.
- Enables the selection of paper type loaded in the printer.
- Switches to the Energy Saver mode, and wakes up from the Energy Saver mode.
- Checks the information on printing, paper exhaustion, and such, on the computer.
- Monitors multiple printers at the same time. When there are many printers, you can create groups and classify the printers to facilitate management.
- Checks the printer's network settings and detailed information of devices.
- Enables you to change the printer's network settings.
- Checks the number of pages printed for each computer, using the user codes.

OS	Protocol Stack
Microsoft Windows 95/98/Me	TCP/IP provided with Windows 95/98/Me IPX/SPX provided with Windows 95/98/Me NetWare network client provided with Windows 95/98 Novell Client for Windows 95/98
Microsoft Windows 2000	TCP/IP provided with Windows 2000 IPX/SPX provided with Windows 2000 NetWare Client provided with Windows 2000 Novell Client for Windows NT/2000
Microsoft Windows XP	TCP/IP provided with Windows 2000 IPX/SPX provided with Windows 2000
Microsoft Windows NT 4.0	TCP/IP provided with Windows NT IPX/SPX provided with Windows NT Client Service for NetWare provided with Windows NT Novell Client for Windows NT/2000

Note

- Select the appropriate protocol stack for your operating system.

Changing the Network Interface Board Configuration

- 1** Run SmartNetMonitor for Admin.
- 2** Click the **[Group]** menu, point to **[Open LAN]**, and then select **[TCP/IP]** or **[IPX/SPX]**. A list of printers appears.

**Note**

- Select the protocol of the printer you want to change its configuration.

- 3** On the list, Select a printer you want to change its configuration.
- 4** From the **[Tools]** menu, select **[NIB Setup Tool]**.
The NIB Setup Tool starts up.
- 5** Select **[Wizard]** or **[Property Sheet]**, and then click **[Next]**.
 - When configuring the Network Interface Board for the first time, select **[Wizard]**.
 - When changing the configuration of the Network Interface Board or configuring it in detail, select **[Property Sheet]**.

Selecting **[Wizard]**

- 1** Fill in the necessary items, and then click **[Next]**.

Selecting **[Property Sheet]**

- 1** A configuration list appears on the dialog box.
For more information about each item on the dialog box, see Help.

Managing the User Information

1 Run SmartNetMonitor for Admin.

2 Click the [Group] menu, point to [Open LAN], and then select [TCP/IP] or [IPX/SPX].

A list of printer appears.

 **Note**

Select the protocol of the printer you want to change its configuration.

3 On the list, Select a printer whose statistics information you want to manage.

4 From the [Tools] menu, select [User Management Tool].

The screen that prompts you to type a password appears.

5 Type the password, and then click [OK].

 **Note**

The factory default password is "password".

The User Code Maintenance Tool starts up.

For more information about using the User Management Tool, see SmartNetMonitor for Admin Help.

Configuring the Energy Save Mode

1 Run SmartNetMonitor for Admin.

2 Click the [Group] menu, point to [Open LAN], and then select [TCP/IP] or [IPX/SPX].

A list of printer appears.

 **Note**

Select the protocol of the printer you want to change its configuration.

3 Click [Group], point to [Energy Save Mode], and select any energy saver mode from the menu that appears.

For more information about settings, see SmartNetMonitor for Admin Help.

Configuring the Network Interface Board with a Web Browser

The Network Interface Board functions as a Web server in addition to allowing a printer to function as a network printer. You can use a Web Browser to view the printer status and configure the Network Interface Board.

❖ Configuring the machine

This requires the TCP/IP protocol to be installed. After the machine has been configured to use the TCP/IP protocol, it will be possible to adjust the settings using a Web Browser.

Reference

For more information about configuring the machine to use the TCP/IP protocol, see the Setup Guide.

❖ Operating system browser requirements

OS	Browser
Windows 95/98/Me	Microsoft Internet Explorer 4.01 or later Netscape Navigator 4.06 or later
Windows NT 4.0	
Windows 2000	
Mac OS 8.6 ~ 9.1	
Solaris 2.5/2.6/2.7/7/8	

Limitation

- Sometimes after clicking [**Back**], the previous page may not appear. In this case, click [**Refresh**] or [**Reload**].
- The text on the screen may disappear or be aligned incorrectly if the font size settings of the browser are too large. It is recommended that you use a font size equal to or smaller than “10 point” with Netscape Navigator, and “Medium” or smaller with Internet Explorer.
- This machine information cannot reload automatically. Click [**Reload**] or [**Refresh**] on the Web browser when you want to reload this machine information.

Going to the Top Page

After launching the Web Browser, type the IP address of the machine. See the example below. This example is for the English version.

`http://192.168.15.16/`

(In this example, the IP address of the Network Interface Board is 192.168.15.16.)

Note

- ❑ If a DNS server is used on the network, you can type the host name as a URL. For example, `http://webmonitor.netprinter.com/`. In order to do this, you must register the IP address and the host name of the Network Interface Board with the DNS server. Consult the network administrator for information about how to do this.
- ❑ When you use the proxy server, you must set up the proxy server address for the Web browser you are using. Consult the network administrator for information about how to set the proxy server.

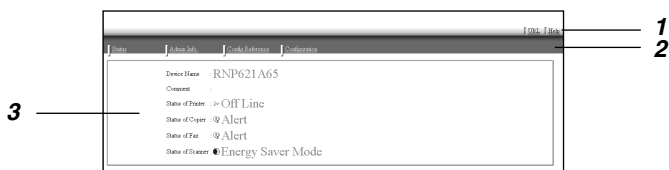

1. Header Buttons

You can register favorite URLs with [URL]. To view the Help section, click [Help].

Important

- ❑ When connecting via a dial-up connection, please be aware that there will be a communication charge as you are logging onto the Internet.

Note

- ❑ The Help files are stored on the CD-ROM labeled "Operating Instructions" in HTML format.

2. Menu Buttons

These Buttons are to configure the Network Interface Board and for checking the status of the machine.

Note

- ❑ When you click [Configuration], a dialog box appears requesting the user name and password. Type only the password in this dialog box. The default password is "password".
- ❑ The password is the same as that used for remote maintenance and that used in the NIB Setup Tool. If you change a password with the Web Browser, the other passwords are also changed.

3. Status

Displays the name and comments of the Network Interface Board, and the printer status.

Configuring the Network Interface Board Settings

1 Start the Web browser.

2 Point your browser at the URL or IP address of the printer (e.g. `http://XXX.XXX.XXX.XXX` where the Xs are the number of the IP address).

The status of the printer you chose appears on the Web browser.

3 Click **[Configuration]**.

The dialog box for entering the password and user name is displayed.

4 Enter your user name and password, and then click **[OK]**.

To use the factory default account, enter no user name and type "password" for the password.

5 Click the item you want to configure, and then make all the settings.

The following items can be configured:

❖ **[General]**

Configure the general settings for the machine here.

❖ **[TCP/IP]**

Configure the TCP/IP-related settings for the Network Interface Board, 802.11b Interface Unit, and 1394 Interface Unit.

❖ **[SNMP]**

Configure the appropriate community settings here. Up to 10 types of community names can be registered.

❖ **[NetWare]**

Configure the settings for printing in a NetWare environment here.

❖ **[AppleTalk]**

Configure the Network Interface Board or 802.11b Interface Unit settings related to the AppleTalk protocol.

❖ **[NetBEUI]**

Configure the Network Interface Board or 802.11b Interface Unit settings related to the NetBEUI protocol here.

❖ **[IEEE 1394]**

Configure the 1394 Interface Unit settings related to IP over 1394 and SCSI print (SBP-2).

🔴 **Limitation**

This page is displayed when the 1394 Interface Unit is installed.

❖ IPP Authentication

If using the IPP protocol, configure the authentication settings for printing here.

❖ Paper Type

Select the paper type loaded in the machine from the drop-down menu.

❖ Password

Follow the procedure below to change the password.

Enter the password to change the network and machine settings or delete spooled print jobs.

❖ IEEE 802.11b (Wireless LAN)

Configure the 802.11b Interface Unit settings related to communication.

🔔 Limitation

This page is displayed when the 802.11b Interface Unit is installed.

Verifying the Network Interface Board Settings

1 Start the Web browser.

2 Point your browser at the URL or IP address of the printer (e.g. <http://XXX.XXX.XXX.XXX> where the Xs are the number of the IP address).

The status of the printer you chose appears on the Web browser.

3 Click [Config. Reference].

The dialog box for entering the password and user name is displayed.

4 Click the item you want to check.

The following items can be checked:

❖ [General]

Shows general settings for the machine.

❖ [TCP/IP]

Shows the TCP/IP-related settings for the Network Interface Board, 802.11b Interface Unit, and 1394 Interface Unit.

❖ [NetWare]

Shows the settings for printing in a NetWare environment.

❖ [AppleTalk]

Shows the Network Interface Board or 802.11b Interface Unit settings related to the AppleTalk protocol.

❖ **[NetBEUI]**

Shows the Network Interface Board or 802.11b Interface Unit settings related to the NetBEUI protocol.

❖ **[IEEE 1394]**

Shows the 1394 Interface Unit settings related to IP over 1394 and SCSI print (SBP-2).

❖ **[IEEE 802.11b (Wireless LAN)]**

Shows the 802.11b Interface Unit settings related to communication.

 **Linking the address (URL) to the [Help] button**

You can link the address (URL) of the **[Help]** button to the Help files on the computer or on a Web server.

- ① Copy the Help files on the CD-ROM to the desired location. The Help files are located in folders labeled with abbreviated language names; for example, English Help files are in the **[EN]** folder. Make sure to copy the entire **[EN]** folder to the new location.
- ② Using a Web Browser, navigate to the Top Page and click **[Network config]**.
- ③ Type your password, (it is not necessary to type a user name) and click **[OK]**.
- ④ Type the path to the Help files in the **[Help URL]** box.
If you copied the Help files to "C:\HELP\EN", type "file:///C:/HELP/". For example if you copied the files to a Web server and the index URL is "http://a.b.c.d/HELP/EN/index.html", type "http://a.b.c.d/HELP/".
- ⑤ Click **[Apply]**.
When a warning message appears, select to continue configuration.

Monitoring and Configuring the Printer

Changing Names and Comments

You can change printer names and make a comment on printers to easily identify the printers listed on SmartNetMonitor for Client.

The following utilities are used to change printer names and comments.

❖ SmartNetMonitor for Admin

Allows you to change names and comments when the TCP/IP protocol or IPX/SPX protocol is available. You can install SmartNetMonitor for Admin from the CD-ROM that comes with the printer. For more information about installing SmartNetMonitor for Admin, see the Setup Guide.

❖ Web Browser

Allows you to change names and comments when the TCP/IP protocol is available.

Note

- Each of the names, in a TCP/IP protocol form (printer name) and in a Net-
BEUI protocol form, is changed individually. Comments are, however,
common to both of them.
- The factory default name consists of "RNP" and the last 3 bytes of the MAC
address on the Network Interface Board. For example, when the MAC ad-
dress is 00:00:74:62:7D:D5, the factory default name is "RNP627DD5".
Comments are not configured.

SmartNetMonitor for Admin

- 1** Run SmartNetMonitor for Admin.
- 2** Click the [Group] menu, point to [Open LAN], and select [TCP/IP] or [IPX/SPX].
A list of printers appears.
 -  Note
 - Select the protocol of the printer you want to change its configuration.
- 3** On the list, Select a printer whose Network Interface Board you want to
change its configuration.
- 4** From the [Tools] menu, select [NIB Setup Tool].
The NIB Setup Tool starts up.

5 Select **[Property Sheet]**, and then click **[OK]**.

TCP/IP

1 Click the **[General]** tab, and then type the device name into the **[Device Name]** box and comment into the **[Comment]** box.

- In the **[Device Name]** box, type the name of the printer in under 13 characters. The factory default name consists of "RNP" and the last 3 bytes of the MAC address on the Network Interface Board. For example, when the MAC address is 00:00:74:62:7D:D5, the factory default name is "RNP627DD5". No name of 9 characters is permitted if the prefix is "RNP". Also, when DHCP is selected as an IP address setting, the number of characters is limited to 13 characters.
- In the **[Comment]** box, type any comment on printers in under 31 characters.

NetBEUI

1 Click the **[General]** tab, and then type the comment into the **[Comment]** box.

In the **[Comment]** box, type any comment on printers in under 31 characters.

2 Click the **[NetBEUI]** tab.

3 Type the computer name into the **[Computer Name]** box.

- In the **[Computer Name]** box, type the name that helps you to identify printers using the NetBEUI protocol. The factory default name consists of "RNP" and the last 3 bytes of the MAC address on the Network Interface Board. For example, when the MAC address is 00:00:74:62:7D:D5, the factory default name is "RNP627DD5". A maximum of 13 characters consisting of uppercase English letters, numeric, or symbols (except "*+,/;<=>?[\]|. and space) can be used. No name is permitted if the prefix is "RNP". You must avoid the duplication of the same name on a network.
- In the **[Comment]** box, type any comment on printers in under 31 characters.

6 Click **[OK]**.

The NIB Setup Tool exits, and the setting is transmitted to the printer.

7 Exit SmartNetMonitor for Admin.

Web Browser

- 1** Run the Web browser.
- 2** Type the address "http:// (IP address of the printer you want to change the settings)".
The status of the selected printer is displayed on the Web browser.
- 3** Click **[Configuration]**.
A dialog box that prompts you to type the user name and a password appears.
- 4** Type the user name and the password, and then click **[OK]**.
Type only the password in this dialog box. The factory default password is "password".
- 5** Change names and comments.

TCP/IP

- 1** Click **[General]**, and then type the name into the **[Device Name:]** box and comment into the **[Comment]** box.
 - In the **[Device Name:]** box, enter the name of the printer in under 13 characters. The factory default name consists of "RNP" and the last 3 bytes of the MAC address on the Network Interface Board. For example, when the MAC address is 00:00:74:62:7D:D5, the factory default name is "RNP627DD5". No name of 9 characters is permitted if the prefix is "RNP". Also, when DHCP is selected as an IP address setting, the number of characters is limited to in under 13 characters.
 - In the **[Comment]** box, type any comment on printers in under 31 characters.
- 2** Click the **[IEEE 1394]**, and then type the name into the **[Device Name:]** box when you change the device name for **IEEE 1394 (IP over 1394) interface**.
 - In the **[Device Name:]** box, enter the name of the printer in under 13 characters. The factory default name consists of "RNP" and the last 5 bytes of the EUI-64 on the IEEE 1394 (IP over 1394) Interface. For example, when the EUI-64 is 00:00:74:00:02:01:0A:66, the factory default name is "RNP0002010A66". No name of 13 characters is permitted if the prefix is "RNP".

NetBEUI

- ❶ Click **[NetBEUI]**.
- ❷ Type the name into the **[Computer Name]** box and comment into the **[Comment]** box.
 - In the **[Computer Name]** box, type the name that helps you to identify printers using the NetBEUI protocol. The factory default name consists of "RNP" and the last 3 bytes of the MAC address on the Network Interface Board. For example, when the MAC address is 00:00:74:62:7D:D5, the factory default name is "RNP627DD5". A maximum of 13 characters consisting of uppercase English letters, numeric, or symbols (except "*+,:/;<=>?[\]|. and space) can be used. No name is permitted if the prefix is "RNP". You must avoid the duplication of the same name on a network.
 - In the **[Comment]** box, type any comment on printers in under 31 characters.

❸ Click **[Apply]**.

The setting is transmitted to the printer.

❹ Exit the Web browser.

7

Displaying the Status of Printer

You can view the status of printers using SmartNetMonitor for Admin, SmartNetMonitor for Client, or Web browser.

SmartNetMonitor for Admin

- ❶ Run SmartNetMonitor for Admin.
- ❷ Click the **[Group]** menu, point to **[Open LAN]**, and then select **[TCP/IP]** or **[IPX/SPX]**.

The status of printers is indicated with an icon in the list.

 **Note**

For more information about the status icons, see SmartNetMonitor for Admin Help.
- ❸ Getting further information, click the desired printer to select from the list, and then click **[Open]** on the **[Device]** menu.

The status of the printer is displayed on the dialog box.

 **Note**

- For more information about each item on the dialog box, see Help.

SmartNetMonitor for Client

Viewing the status of printers using SmartNetMonitor for Client, you must, in advance, configure SmartNetMonitor for Client so it monitors the printer whose status you want to view.

Monitoring Printers

1 Run SmartNetMonitor for Client.

The SmartNetMonitor for Client icon appears at the right end of the taskbar.

2 Right-click the SmartNetMonitor for Client icon, and check if the desired printer is configured on the pop-up menu that appears.

If it is configured, see SmartNetMonitor for Client Help.

3 If the desired printer is not configured, click [Options] on the pop-up menu.

The [SmartNetMonitor for Client - Options] dialog box appears.

4 Click the printer to be monitored, and select the [To Be Monitored] check box from the [Monitoring Information Settings] group.

Note

- Selecting the [Displayed on Task Bar] check box will bring up the status of a printer with an icon on the SmartNetMonitor for Client icon on the task tray.

5 Click [OK].

The dialog box closes and the configured printer is monitored.

Displaying the Status of Printers

1 Run SmartNetMonitor for Client.

2 The status of printers is displayed on the SmartNetMonitor for Client icon on the task tray.

Note

- For more information about the status icons, see SmartNetMonitor for Client Help.

3 Getting further information on the status, right-click the SmartNetMonitor for Client icon, and then click the desired printer.

The status of the printer is displayed on the dialog box.

Note

- For more information about each item on the dialog box, see Help.

Web Browser

- 1** Run the Web browser.
- 2** Type the address "http:// (IP address of the printer whose status you want to view)".
The status of the selected printer is displayed on the Web browser.
- 3** Click [Status] and you can check the status of the printer.

 **Note**

- For more information about each item, see Help.

Using the IEEE 802.11b (Wireless LAN)

Preparation

Use the WiFi authorized card for an access point and the IEEE 802.11b card in the computer.

Setting IEEE 802.11b (Wireless LAN)

Connect the printer and the computer in Ad hoc Mode. Then set up IEEE 802.11b (Wireless LAN) according to your network environment using the following procedure.

Limitation

- To connect in Infrastructure Mode, after connecting the printer and the computer in Ad hoc Mode, make settings using a Web browser and telnet by following procedures ❸ to ❹ in "Using in Infrastructure Mode".

Using in Ad hoc Mode	See p.88 "Using in Ad hoc Mode".
Using in Infrastructure Mode	❶ See p.88 "Using in Ad hoc Mode". ❷ See p.89 "Using in Infrastructure Mode". ❸ See p.90 "Setting SSID". ❹ See p.90 "Applying the Settings". ❺ See p.91 "Confirming the Connection".
Using WEP	When using WEP, the following procedures are required after ❸, "Setting SSID". ❸-❶ See p.90 "Setting the WEP Key". ❸-❷ See p.90 "Using WEP".

Using in Ad hoc Mode

1 Press [Menu].

"Menu" appears on the panel display.

2 Press [▲] or [▼] to display "Host Interface", and then click [OK].

```
Menu:
Host Interface
```

3 Press [▲] or [▼] to display "Network Setup", and then click [OK].

```
Host Interface:
Network Setup
```

The following is displayed when installing the 802.11b Interface Unit in the printer with Ethernet as standard equipment.

If the 802.11b Interface Unit has been installed in the printer with Ethernet as standard equipment, go to step 6.

4 Press [▲] or [▼] to display "LAN Type", and then click [OK].

```
Network Setup:
LAN Type
```

5 Press [▲] or [▼] to display "IEEE 802.11b ", and then click [OK].

```
LAN Type:
IEEE 802.11b
```

6 Make the network settings. The following items must be set:

- IP Address
- Subnet Mask
- Gateway Address
- Network Boot
- Frame Type (NW)
- Active Protocol

For more information about how to make the settings, see the Setup Guide.

7 Make setting for the computer.

Set the transmission mode of the IEEE 802.11b card installed in the computer to ad hoc mode and the channel to 11. Make the computer network settings. The following items must be set:

- IP Address
- Subnet Mask

Reference

For more information about how to make setting for the IEEE 802.11b card installed in the computer and the computer in use, see the appropriate operating instructions or consult your network administrator.

Note

- Depending on the client software of the IEEE 802.11b card installed in the computer, the channels might not be able to be set. In this case, set the printer channel to the channel specified by the computer.

- ❑ Depending on the client software of the IEEE 802.11b card installed in the computer, setting IBSS (Independent Base Service Set or Network Name) may be required. If you have to make settings, set the value as "ASSID".
- ❑ In an IEEE 802.11b environment using the access point set as "ASSID" in SSID, you may not be able to connect the computer and the printer in ad hoc mode.

8 Press **[On Line]**.

9 Make sure the computer and the printer are connected.

Reference

See p.91 "Confirming the Connection".

Using in Infrastructure Mode

Make setting for infrastructure mode from the control panel of the printer, telnet, or a Web browser.

For more information about how to make settings from the control panel of the printer, see the Setup Guide.

For more information about how to use telnet and a Web browser, see p.76 "Configuring the Network Interface Board with a Web Browser" or p.92 "Remote Maintenance by telnet".

The following procedure uses a Web browser.

Preparation

When using the printer in infrastructure mode, you need the access point in use or information (SSID and WEP key) about the access point that will be used. Make SSID and WEP key settings at the same time.

For access point information, see the appropriate operating instructions, or consult your network administrator.

Changing to Infrastructure Mode

1 Start the Web browser of a wireless LAN client connected in ad hoc mode.

2 Point your browser at the URL or IP address of the printer (e.g. `http://XXX.XXX.XXX.XXX` where the Xs are the number of the IP address).

The status of the printer you chose appears on the Web browser.

3 Click **[Configuration]**.

The dialog box for entering the password and user name is displayed.

4 Enter your user name and password, and then click **[OK]**.

5 Click **[IEEE 802.11b]**.

6 Change **[Communication Mode]** to **[Infrastructure mode]**.

If using SSID, see p.90 "Setting SSID".

If not using SSID, see p.90 "Applying the Settings".

Setting SSID

1 Click [IEEE 802.11b].

2 Enter a value in [SSID].

Important

- If you cannot connect after making SSID and WEP key settings, select "WL.LAN Defaults" from the control panel, and then set IEEE 802.11b (wireless LAN) from the beginning. For more information about how to use the control panel, see the Setup Guide.

Note

- The character strings to be set are in the range ASCII 0x20-0x7e and the SSID is case-sensitive to 32 bytes.

If using the WEP key, see p.90 "Setting the WEP Key".

If not using the WEP key, see p.90 "Applying the Settings".

Setting the WEP Key

1 Click [IEEE 802.11b].

2 Enter a value in [WEPKey].

Note

- You can set only 10 hexadecimal character strings.

3 Change to enable use of WEP.

See p.90 "Using WEP".

Using WEP

Important

- To enable the WEP key, be sure to first enter a value for the WEP key. See p.90 "Setting the WEP Key".
- With some products, depending on the access point or IEEE 802.11b card in use, it is possible to set more than one WEP key. In this case, make the first key the same as the WEP key set in the printer.

1 Click [IEEE 802.11b].

2 Change [Encryption] to [Enable].

3 Apply all the settings.

See p.90 "Applying the Settings".

Important

- If you cannot connect after making SSID and WEP key settings, select "WL.LAN Defaults", and then make setting for IEEE 802.11b (wireless LAN) from the beginning. For more information about how to use the control panel, see the Setup Guide.

Applying the Settings

1 Click [Refresh] or [Reload].

The settings are transmitted.

Note

- To verify the settings, click [Config Reference], and then click [IEEE 802.11b].

2 Exit the Web browser.

Confirming the Connection

- 1** Make sure the LED of the IEEE 802.11b card is lit.

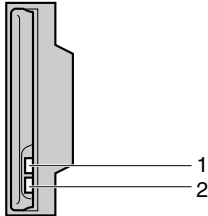

ZGDH600J

1. If the IEEE 802.11b card is on, it lights in orange. If the IEEE 802.11b (wireless LAN) is not selected, it does not light, even if the printer power is on.

2. If it is connected properly to a network, the LED lights in green with infrastructure mode, it is not connected to a network. Check the network environment.

2 Use a Web browser to check that the printer is connected properly. See p.76 "Configuring the Network Interface Board with a Web Browser".

3 Print the configuration page to verify the settings.

For information about how to print the configuration page, see the Setup Guide.

Remote Maintenance by telnet

You can view the printer status and configure the Network Interface Board using telnet.

Note

- You should specify a password so that only the network administrator, or a person having network administrator privileges, can use remote maintenance.

Using telnet

The following is a sample procedure using telnet.

Limitation

- Only one person at a time can be logged on to do remote maintenance.

1 Using the IP address or host name of the machine, start telnet.

```
% telnet IP_address
```

Note

- In order to use the host name instead of the IP address, you must write it to the hosts file.

2 Type the password.

Note

- The default is "password".

3 Type a command.

Reference

For more information about telnet commands, see p.93 "Commands List".

4 Exit telnet.

```
msh> logout
```

When the configuration is changed, a message requests whether or not the changes should be saved.

5 Type "yes" to save the changes, and then press the **[ENTER]** key.

If you do not want to save the changes, type "no", and then press the **[ENTER]** key. If you want to make additional changes, type "return" at the command line, and then press the **[ENTER]** key.

Note

- If the "Cannot write NVRAM information" message appears, the changes are not saved. Repeat the steps above.
- The Network Interface Board is reset automatically when the settings are changed.

- When the Network Interface Board is reset, the active print job which has already been sent to the machine will finish printing. However, jobs that have not been sent yet will be canceled.

Commands List

Use this command to display remote maintenance use.

Note

- Type “help” to see a list of commands that can be used.

```
msh> help
```

- Type “help command_name” to display information about the syntax of that command.

```
msh> help command_name
```

TCP/IP address

Use the ifconfig command to configure TCP/IP (IP address, subnet mask, broadcast address, default gateway address) for the machine.

◆ Reference

```
msh> ifconfig
```

◆ Configuration

```
msh> ifconfig interface_name parameter address
```

Interface name	Interface to be configured
ether naf0	Ethernet Interface *1
ip1394 *2 fwip0 *2	IEEE 1394 Interface
wlan *3 wi0 *3	IEEE 802.11b Interface

*1 If you did not enter the interface name, it will be automatically set to the Ethernet interface.

*2 Available when the 1394 Interface Unit Type 4510 is installed.

*3 You can specify an interface when installing the optional 802.11b Interface Unit Type A.

Parameter	Meaning
(no parameter)	IP address
netmask	subnet mask
broadcast	broadcast address

❖ **Changing the Interface**

You can specify either the LAN interface or IEEE 802.11b interface when using the optional 802.11b Interface Unit.

```
msh> ifconfig interface up
```

 **Note**

- You cannot specify the optional IEEE 1394 Interface Unit.

The following is an example for configuring an IP address of 192.168.15.16 on Ethernet interface.

```
msh> ifconfig ether 192.168.15.16
```

The following is an example for configuring a subnet mask of 255.255.255.0 on Ethernet interface.

```
msh> ifconfig ether netmask 255.255.255.0
```

 **Note**

- This affects the configuration of the Network Interface Board of the IP address that is used.
- The TCP/IP setting is the same as that for the LAN interface and IEEE 802.11b interface.
- To type an address using hexadecimal, prefix it by "0x".



 **Address**

❖ **Subnet Mask**

A number used to mathematically “mask” or hide the IP address on the network by eliminating those parts of the address that are alike for all the machines on the network.

 **Note**

- To get the above addresses, contact your network administrator.
- The subnet mask is the same as that for the LAN interface and IEEE 802.11b interface.
- When installing the optional 1394 Interface Unit, set the subnet so that it does not overlap with the LAN interface or the 1394 interface.



Access Control

Use the access command to view and configure access control. You can also specify two or more access ranges.

❖ Reference

```
msh> access
```

❖ Configuration

```
msh> access ☆ range start-address end-address
```

- ☆ represents a target number between 1 and 5. (Up to five access ranges can be registered and selected.)

Example: To specify accessible IP addresses between 192.168.0.10 and 192.168.0.20:

```
msh> access 1 range 192.168.0.10 192.168.0.20
```

Note

- The access range restricts the workstations from which printing is possible by means of an address. If you do not need to restrict printing, make the setting "0.0.0.0".
- The entry is invalid if the start address is greater than the end address.
- Up to five access ranges can be specified. The entry is invalid if the target number is omitted.
- When using a Web browser, telnet or SmartNetMonitor for Client/Admin, you can use an IP address that has not been restricted by access control.

❖ Access Control Initialization

```
msh> access flush
```

Note

- This restores the factory-default settings so that all access ranges become "0.0.0.0".

Network Boot

Use the set command to configure the boot method.

```
msh> set parameter {on | off}
```

"on" means active and "off" means inactive.

Parameter	Meaning
dhcp	DHCP (Dynamic Host Configuration Protocol)

Note

- When you use DHCP, the server also needs to be configured.
- DHCP takes precedence over all other settings.

Protocol

Use the set command to allow/prevent remote access for each protocol.

```
msh> set protocol {up | down}
```

Protocol	
appletalk tcpip netware netbeui scsiprint *1 ip1394 *1 lpr ftp rsh diprint web snmp ipp	"up" means active and "down" means inactive.

*1 Available when the 1394 Interface Unit Type 4510 is installed.

 **Note**

- If you prohibit remote access using TCP/IP and then log out, you cannot use remote access. If this was a mistake, you can use the control panel to allow access by TCP/IP.
- When you prevent access via TCP/IP, you are also prevented from using ip1394, lpr, ftp, rsh, diprint, web, snmp and ipp.

Printer status

The following commands can be used to get information about the current status of the printer.

```
msh> command
```

Command	Information that is displayed
status	Status of printer. Information about the print jobs.
info	Information about the paper tray, output tray, printer language of printer.
prnlog [ID]	Lists the last 16 print jobs.

 **Note**

- More information about any print job is displayed when the ID number is added after the prnlog command.

Reference

For more information about the meaning of the data returned with these commands, see p.110 “Configuring the Network Interface Board”.

Network Interface Board configuration settings information

Use the show command to display the Network Interface Board configuration settings.

```
msh> show [-p]
```

Note

- Add “-p” to the show command to have the information displayed one screen at a time.

Reference

For more information about the meaning of the data returned with this command, see p.110 “Configuring the Network Interface Board”.

System log information

Use the syslog command to display information stored in the machine's system log.

```
msh> syslog
```

Reference

For more information about the displayed information, see p.113 “System Log Information”.

SNMP

Use the snmp command to display and edit SNMP configuration settings such as the community name.

Note

- The 1394 Interface Unit Type 4510 supports TCP/IP only.
- You can configure from ten SNMP access settings numbered 1–10.
- Default access settings 1 and 2 are as follows.

Number	1	2
Community name	public	admin
IP address	0.0.0.0	0.0.0.0
Access type	read-only trap off	read-write trap off

❖ Display

Shows the SNMP information and available protocols.

```
msh> snmp ?
msh> snmp [-p] [registered_number]
```

Note

- If the -p option is added, you can view the settings one by one.
- Omitting the number displays all access settings.

❖ Community name configuration

You can set the community name of the registered number.

```
msh> snmp number name community_name
```

Note

- The community name must consist of 15 characters or less.

❖ Access type configuration

You can select the access type from those listed below.

```
msh> snmp number type access_type
```

Access type	Type of access which is permitted
read	Read only
write	Read and write
trap	User is notified of trap messages.
no	All access is denied.

❖ Protocol configuration

You should use the following command to set the protocols to active or inactive. If you set a protocol to inactive, all access settings set to use that protocol will be disabled.

```
msh> snmp {ip | ipx} {on | off}
```

- “on” means active and “off” means inactive

To change the protocol of an access settings, use the following command. However, if you disabled a protocol with the above command, making it active here will have no effect.

```
msh> snmp number active {ip | ipx} {on | off}
```

❖ Access configuration

You can configure the address of a host depending on the protocols used.

The Network Interface Board accepts requests only from hosts having addresses with access types of “read-only” or “read-write”. Type “0” to have the Network Interface Board accept requests from any host without requiring a specific type of access.

Command syntax:

```
msh> snmp number {ip | ipx} address
```

Note

- ❑ To specify the TCP/IP protocol, type `ip` followed by a space, and then the IP address.
- ❑ To specify the IPX/SPX protocol, type `ipx` followed by a space, and then the IPX address followed by a decimal, and then the MAC address of the Network Interface Board.

The following is an example of how to configure registration number 3 with the IP address 192.168.15.16.

```
msh> snmp 3 ip 192.168.15.16
```

The following is an example of how to configure registration number 3 with the IPX address 7390A448, and the MAC address 00:00:74:62:5C:65.

```
msh> snmp 3 ipx 7390A448:000074625C65
```

IPP

Use the `ipp` command to configure the IPP settings.

❖ Viewing setting

The following command displays the current IPP settings.

```
msh> ipp
```

Example output:

```
timeout=900(sec)
auth basic
```

- The “timeout” setting specifies how many seconds the computer keeps trying to access the network printer to send print jobs when no connection can be made.
- The “auth” setting indicates the user authorization mode.

❖ IPP timeout configuration

Specify how many seconds to wait before canceling a print job if it has been interrupted for some reason. The range of time can be changed between 30 to 65535 seconds.

```
msh> ipp timeout {30 - 65535}
```

❖ IPP user authorization configuration

Use the IPP user authorization to restrict users that can print with IPP. The default is “off” .

```
ipp auth {basic|digest|off}
```

- “basic” and “digest” are user authorization setting.
- “off” removes the user's authorization.

Note

- ❑ If you select “basic” or “digest”, see next section “Entry the IPP User Authorization” for how to configure the user name. Up to ten user names are available.

❖ Configuring the IPP user authorization

Use the following command:

```
ipp user
```

The following message appears.

```
Input user number (1 to 10):
```

Type the number, user name and password.

```
IPP user name:user1
```

```
IPP password:*****
```

After configuring the settings, the following message appears.

```
User configuration changed.
```

Direct Printing Port

The direct printing port allows printing directly from a computer, connected to the network, to the printer.

Use the `diprint` command to change the direct printing port settings.

❖ View settings

The following command displays the current direct printing port settings.

```
msh> diprint
```

Example output:

```
port 9100
```

```
timeout=300(sec)
```

```
bidirect off
```

- The “Port” specifies the port number of the direct printing port.
- The “bidirect” setting indicates whether the direct printing port is bidirectional.

❖ Setting timeout

You can specify the timeout interval to use when receiving data from the network.

```
msh> diprint [0~65535]
```

Note

- The factory default is 300 seconds.
- If 0 is set, timeout is disabled.

❖ Bidirectional configuration for the direct printing port

Use this setting to configure whether the direct printing port is bidirectional. The factory default is “off”.

```
msh> diprint bidirect {on|off}
```

Note

- If you select “on”, SmartNetMonitor for Client or Standard TCP/IP on Windows 2000 might not work correctly.

SMB

Use the `smb` command to configure or delete the computer name or workgroup name for NetBEUI.

msh> smb parameter

Parameter	Settings
comp	Your computer name consisting of up to 13 characters
group	Workgroup name consisting of up to 15 characters
comment	Comment consisting of up to 31 characters
clear comp	Clears the computer name
clear group	Clears the Workgroup name
clear comment	Clears comment

ROUTE

Use the `route` command to control the routing table.

This command allows you to configure and display routing information. You can change the network configuration from remote PCs using this command.

Note

- ❑ The maximum number of routing tables are 16.

Commands	Topics of setting
route add {host net} destination * ¹ gateway * ¹	Adds a host/network route to "destination", and a gateway address to "gateway" in the table. Host becomes the default setting.
route delete {host net} destination * ¹	Deletes a host/network route from the table. Host becomes the default setting.
route get {destination * ¹ }	Displays only route information corresponding to a specified destination. When the destination is unspecified, all routing information is displayed.
route active {host net} destination * ¹ on/off	You can turn the specified destination on or off. Host becomes the default setting.
route add default gateway * ¹	You can set the default gateway address.
route flush	Deletes all routing information.

*¹ IP address

SLP

Use this command to configure SLP settings.

You can search the NetWare server using SLP in the PureIP environment of NetWare5/5.1. To use the `slp` command, you can configure the value of TTL which can be used by the SLP multi-cast-packet.

 **Note**

- The default value of TTL is "1". A search is executed only within a local segment. If the router does not support multi-cast, the settings are not available even if the TTL value is increased.
- The acceptable TTL value is 1 - 255.

```
msh> slp ttl {1 - 255}
```

Setting IEEE 802.11b

To make setting for IEEE 802.11b, use the `wiconfig` command.

 **Limitation**

- You can make settings when installing the optional 802.11b Interface Unit.

 **View settings**

The IEEE 802.11b settings are displayed.

```
msh> wiconfig
```

The IEEE 802.11b card information is displayed.

```
msh> wiconfig cardinfo
```

 **Note**

- If the IEEE 802.11b interface is not working correctly, the IEEE 802.11b card information is not displayed.

 **Configuration**

Parameter	Value to be configured
mode [ap adhoc]	You can set infrastructure mode (ap) or ad hoc mode (adhoc). The default is ad hoc mode.
ssid <i>ID value</i>	You can set for SSID in infrastructure mode. The characters that can be used are ASCII 0x20-0x7e (32 bytes). A SSID value is set automatically to the nearest access point if the setting has not been made. If the setting has not been made for ad hoc mode, the same value as for infrastructure mode or an "ASSID" value is set automatically if the setting has not been made.

Parameter	Value to be configured
channel frequency <i>channel no.</i>	You can set the channel. You can specify from following channel. <ul style="list-style-type: none"> • Metric Version :1-13 • Inch Version :1-11 Set the same channel for all the machines you are using.
enc [on off]	You can enable or disable the WEP function. To enable the WEP function, specify [on]; to disable it, specify [off]. To start the WEP function, enter the correct WEP key.
key [<i>key value</i>]	Only 10 hexadecimal characters can be used. To use this function, set the same WEP key for all the ports that transmit to each other.
auth [open shared]	You can set the authorized mode when using WEP. The specified value and the authorized mode are as follows: open: Open system authorized (default) shared: Shared key authorized
rate [auto 11m 5.5m 2m 1m]	You can set the IEEE 802.11b transmitting speed. The transmitting speed you specify here is the speed at which data is sent. You can receive data at any speed. auto: automatically set (default) 11m: 11 Mbps fixed 5.5m: 5.5 Mbps fixed 2m: 2 Mbps fixed 1m: 1 Mbps fixed

Job Spool

Use this command to configure Job Spool settings.

Limitation

- You can only specify the LPR and IPP protocol.

Note

- This machine information cannot reload automatically when you confirm the Job spool settings on the Web browser. Click **[Reload]** or **[Refresh]** on the Web browser when you want to reload this machine information.

Reference

The job spool setting appears.

```
msh> spoolsw
```

❖ Job Spool Setting

```
msh> spoolsw spool {on | off}
```

Note

Specify "on" to enable the job spool function or "off" to disable it.

❖ Clearing Spool Job

If the printer is turned off accidentally during a spool job, you can specify whether the job will be reprinted when the printer is turned back on.

```
msh> spoolsw clearjob {on | off}
```

❖ Protocol Configuration

To change the protocol settings, use the following command. You can specify the setting for [lpr] or [ipp].

- lpr

```
msh> spoolsw lpr {on | off}
```

- ipp

```
msh> spoolsw ipp {on | off}
```

Changing the Host Name

Use the hostname command to change the printer name.

```
msh> hostname [interface_name ] printer_name
```

interface name	Interface to be configured
ether	Ethernet interface *1
wlan *2	IEEE 802.11b interface
ip1394 *3	IEEE 1394 interface

*1 If you did not enter the interface name, it will be automatically set to the Ethernet interface.

*2 If you install the 802.11b Interface Unit Type A, you can set the command.

*3 If you install the 1394 Interface Unit Type 4510, you can set the command.

Note

- Enter the printer name using up to 13 characters.
- You cannot use a printer name starting with RNP or rnp.
- The Ethernet interface and IEEE 802.11b interface will have the same printer name.

WINS

Use the `wins` command to configure the WINS server settings

For more information about WINS server settings, see p.122 “Configuring a WINS Server”.

❖ Viewing setting

The following command displays the WINS server IP address.

```
msh> wins
```

Example out put:

```
wins: primary server 0.0.0.0 secondary server 0.0.0.0
DHCP current config:
  primary server 192.168.10.1 secondary server
192.168.10.2
  hostname RNP620B47 ScopeID
```

Note

- If DHCP is used to start from the network, the current WINS server address is displayed. This address, however, is not displayed if DHCP is not used.
- If the IP address obtained from DHCP differs from the WINS IP address, the DHCP address is the valid address.

❖ Configuration

Use the `set` command to make WINS active or inactive.

```
msh> set wins {on|off}
```

- "on means active and "off" means inactive.

❖ Address configuration

Use this command to configure a WINS server IP address.

```
msh> wins {primary|secondary} IP_address
```

Note

- Use the "primary" to configure a primary WINS server IP address.
- Use the "secondary " to configure a secondary WINS server IP address.

AutoNet

Use the `set` command to configure AutoNet.

Note

- For more information about AutoNet, see p.121 “Using AutoNet”.

```
msh> set autonet {on|off}
```

"on" means active and "off" means inactive.

SNTP

The printer clock can be synchronized with a NTP server clock using the Simple Network Time Protocol (SNTP). To change the SNTP settings, use the `sntp` command. Confirm with the network administrator that the NTP server settings are correct.

Limitation

- SNTP supports the NTP servers running `xnptd V3` and `V4`.

❖ Reference

```
msh> sntp
```

❖ NTP Server Address Configuration

You can specify the IP address of the NTP server.

```
msh> sntp server IP_address
```

❖ Interval Configuration

You can specify the interval at which the printer synchronizes with the operator-specified NTP server.

```
msh> sntp interval polling_time
```

Note

- The factory default setting is 3600 seconds.
- You can set the interval from 16 to 16384 seconds.
- If you set 0, the printer synchronizes with the NTP server only when you turn the printer on. After that, the printer does not synchronize with the NTP server.

❖ Time-zone Configuration

You can specify the time difference between the printer clock and the NTP server clock.

```
msh> sntp timezone +/-hour_time
```

Example: To set the time-zone difference to +8 hours:

```
msh> sntp timezone +08:00
```

Note

- The time is in 24-hour notation.

Changing the password

Use the `passwd` command to change the remote maintenance password.

Important

- Be sure not to forget or lose the password.

Note

- The default password is “password”.

1 Type “passwd”.

```
msh> passwd
```

2 Type the current password.

```
Old password:
```

3 Type the new password.

```
New password:
```

Note

- The password must consist of 3 to 8 alphanumeric characters and symbols. Upper and lower case characters are considered unique. For example, R is different from r.
- The password is the same as that used in the configuration of the Network Interface Board using a Web Browser and that used in the NIB Setup Tool. If you change a password from telnet, the other passwords are also changed.

4 Type the new password once again.

```
Retype new password:
```

SNMP

The Network Interface Board functions as an SNMP (Simple Network Management Protocol) agent using the UDP and IPX protocols. Using the SNMP manager you can get information about the printer.

The default community names are “public” and “admin”. You can get MIB information using these community names.

Reference

You can configure SNMP from the command line using telnet. See p.97 “SNMP”.

You can configure SNMP from SmartNetMonitor for Admin using the NIB Setup Tool. See Help for SmartNetMonitor for Admin.

You can configure SNMP from your Web browser. See Help on the CD-ROM.

Limitation

- The kinds of supported MIBs vary depending on the printer.

Supported MIBs

- MIB-II
- PrinterMIB
- HostResourceMIB
- RicohPrivateMIB

Understanding the Displayed Information

This section describes how to read the status information returned by the Network Interface Board.

Print Job Information

The status of the print job can be viewed using the following commands.

- telnet : Use the status command. See p.96 “Printer status” .

Item name	Meaning
Rank	Print job status. <ul style="list-style-type: none"> • Active Printing or preparing for printing. • Waiting Waiting to be transferred to the printer.
Owner	Print request user name.
Job	Print request number.
Files	The name of the document.
Total Size	The size of the data (spooled). The default is “0 bytes”.

Print Log Information

This is a record of the most recent 16 jobs that have been printed.

This log can be displayed with the following commands.

- telnet : Use the prnlog command. See p.96 “Printer status” .

Name	Meaning
ID	Print request ID.
User	Print request user name.
Page	The number of pages that is printed.
Result	The result of the print request.
Time	The time when the print request was received
UserID ^{*1}	User ID that is to be configured in the printer driver.
JobName ^{*1}	The name of the document for printing.

^{*1} Appears the UserID and JobName information when entering the info command with the ID.

Item name	Meaning
TCP/IP Mode ftp lpr rsh diprint web telnet snmp ipp EncapType Network boot Address Netmask Broadcast Gateway Access Range[☆] *2 Primary WINS Secondary WINS Time server Time Zone Time server polling time Home page URL Home page link name Help page URL SNMP protocol	Up means active, Down means inactive. Frame type. Network boot. IP address. Subnet mask. Broadcast address. Default gateway address. Access Control Range. Primary WINS server address. Secondary WINS server address. NTP server address NTP server time difference Synchronizes interval URL of homepage. URL name of homepage. URL of help page. Protocol used with SNMP.
NetWare EncapType RPRINTER number Print server name File server name Context name Switch Mode NDS/Bindery Packet negotiation Print job timeout	Frame type. Remote printer number. Print server name. Name of the connect file server. Context of print server. Active mode. (this value is fixed) Time of the job timeout.

Item name	Meaning
NetBEUI Switch Mode diprint Notification Workgroup name Computer name Comment Share name[1]	(this value is fixed) (this value is fixed) Notification of print job completion. Name of the workgroup. Name of the computer. Comment. Share name (name of the printer type).
IEEE 802.11b ^{*3} SSID Channel range Channel Communication mode Rate WEP encryption Auth Encryption key	SSID being used. Channels available for use. Channel being used. IEEE 802.11b interface transmitting mode. IEEE 802.11b interface speed. Whether WEP is enabled or disabled. Validity or invalidity of the authorized mode setting when using WEP. WEP key.
IP over 1394 ^{*4} Device name Address Netmask Broadcast	IP address. Subnet mask. Broadcast address.
SCSI print ^{*4} Bidi.	Bidirectional setting (on/off).
Shell mode	Mode of the remote maintenance tool.

^{*1} The 1394 Interface Unit Type 4510 supports TCP/IP only.

^{*2} ☆ represents a target number between 1 and 5.

^{*3} You can display the item names when installing the optional 802.11b Interface Unit Type A.

^{*4} You can display the item names when installing the optional 1394 Interface Unit Type 4510.

Message List

This is a list of messages written to the machine's system log. The system log can be viewed using the syslog command.

System Log Information

You can use the following methods to view the system log.

- telnet : Use the syslog command. See p.97 “System log information” .

Message	Description and Solutions
Access to NetWare server <file server name> denied. Either there is no account for this print server on the NetWare server or the password was incorrect.	(In print server mode) Cannot log in to the file server. Make sure that the print server is registered on the file server. If a password is specified for the print server, delete it.
add_sess: community<community name> already defined.	The same community name already exists. Use another community name.
add_sess: session<community name> not defined.	A requested community name is not defined.
add_sess: bad trap addr:<IpAddress>, community:<community name>	The IP address (0.0.0.0) is unavailable when the community access type is TRAP. Specify the host IP address for the TRAP destination.
add_sess_ipx: bad trap addr: <IPX address>, community:<community name>	The IPX address (00:00:00:00:00:00) is unavailable when the community access type is TRAP. Specify the host IPX address for the TRAP destination.
add_sess_ipx: community <community name> already defined.	The same community name already exists. Use another community name.
add_sess_ipx:session_ipx<community name> not defined.	A requested community name is not defined.
ANONYMOUS FTP LOGIN FROM <IP address>, <password>	An anonymous login has been made with a password <password> from the host <IP address>.
anpd start. (AppleTalk)	An anpd (AppleTalk Network Package Daemon) has started.
Attach FileServer =<file server name>	Attached to the file server as a nearest server.
Attach to print queue <print queue name>	(In print server mode) Attached to the print queue name.
Cannot create service connection	(In remote printer mode) Cannot establish a connection with the file server. The number of file server users may exceed the maximum number that the file server can handle.

Message	Description and Solutions
Cannot find rprinter (<print server name>/<printer number>)	The printer having the number displayed on the print server does not exist. Make sure that the number of the printer is registered in the print server.
Change IP address from DHCP Server.	The IP address changes when DHCP LEASE is renewed. To always assign the same IP address, set a static IP address to the DHCP server.
child process exec error! (process name)	Failed to start the network service. Turn the printer off and then on. If this does not work, contact your service or sales representatives.
Connected DHCP Server(<DHCP server address>).	The IP address was successfully received from the DHCP server.
connection from <IP address>	Logged on from the host <IP address>.
Could not attach to FileServer<error number>	(In remote printer mode) Cannot attach to the file server. For some reason, the file server refuses the connection. Check the file server configuration.
Could not attach to PServer<print server>	(In remote printer mode) Cannot attach to the print server. For some reason, the print server refuses the connection. Check the print server configuration.
Current Interface Speed:xxxMbps	The speed of the network (10 Mbps or 100 Mbps).
Current IP address <current IP address>	The IP address <current IP address> was received from the DHCP server.
Current IPX address<IPX address>	The current IPX address.
DHCP lease time expired.	DHCP lease time has expired. The printer tries to discover the DHCP server again. The IP address used up to now becomes invalid.
DHCP server not found.	The DHCP server cannot be found. Make sure the DHCP server is running on the network.
dhcpcd start.	A dhcpcd (DHCP client service) has started.
Duplicate IP=<IP address>(from <MAC address>).	The same IP address is used. An IP address must be unique. Check the address of the device indicated in <MAC address>.
Established SPX Connection with PServer, (RPSocket=<socket number>, connID=<connection ID>)	(In remote printer mode) A connection with the print server has been established.
exiting	lpd service has ended and the system is exiting the process.

Message	Description and Solutions
Exit pserver	(In print server mode) Exits the print server because the necessary print server settings have not been made.
Frametype =<frame type name>	The <frame type name> is configured to be used on NetWare.
httpd start.	An httpd has started.
IEEE 802.11b current channel <Channel>	The current channel is displayed. The value chosen by the user is displayed in ad hoc mode. The channel used in the access point is displayed in infrastructure mode. (Example: Current channel is 11.) IEEE 802.11b current channel 11
IEEE 802.11b MAC Address = <MAC Address>	The IEEE 802.11b I/F MAC address is displayed. (Example: Current MAC address is 00:00:74:XX:XX:XX.) IEEE 802.11b MAC Address = 00:00:74:XX:XX:XX
IEEE 802.11b SSID <ssid> (AP MAC Address <MAC Address>)	The SSID of the access point used in infrastructure mode and the MAC address of the access point are displayed. (Example: Current MAC address is xx:xx:xx:xx:xx:xx and SSID value is "test-ssid".) IEEE 802.11b SSID test-ssid (AP MAC Address xx:xx:xx:xx:xx:xx)
IEEE 802.11b Tx Rate <Transfer Speed>	The IEEE 802.11b transmitting speed (set speed) is displayed. (Example: Current Tx Rate is 11Mbps.) IEEE 802.11b Tx Rate 11Mbps
inetd start.	An inetd has started.
<interface> started with IP: <IP address>	<IP address> has been set for <Interface> and <Interface> started.
<Interface>: Subnet overlap.	Subnet from Netmask and the IP address you tried to set for <Interface> overlap the subnet for another interface. Set Subnet so that it does not overlap with another interface.
IPP cancel-job: permission denied.	The printer could not authenticate the name of the user attempting to cancel a job.
ipp disable.	Printing with ipp is disabled.
ipp enable.	Printing with ipp is enabled.

Message	Description and Solutions
IPP job canceled. jobid=%d.	The spooled job has been canceled due to an error or by user request.
job canceled. jobid=%d.	The spooled job has been canceled due to an error or by user request.
LeaseTime=<lease time>(sec), Renew-Time=<renew time>(sec).	The resource lease time that was received from the DHCP server is <lease time> in seconds. The renewal time is also <renew time> in seconds.
Login to fileserver <file server name> (<IPX IP>,<NDS BINDERY>)	(In print server mode) Logged in to the file server with NDS or BINDERY mode.
multid start.	Data transmission service for multiprotocols has started.
nbstart start. (NetBEUI)	The service for NetBEUI protocol stack setting has started.
NBT Registration Broadcast(<NetBIOS name>)	Use a local broadcast to map <NetBIOS name> with the IP address.
nbttd start.	A nbttd (NetBIOS over TCP/IP Daemon) has started. (Available only in DHCP mode)
NetBEUI Computer Name =<computer name>	The NetBEUI Computer Name is defined as <computer name>.
nmsd start. (NetBEUI)	A nmsd (Name Server Daemon) has started.
npriter start. (NetWare)	(In remote printer mode) NetWare service has started.
nwstart start. (NetWare)	The service for NetWare protocol stack setting has started.
Open log file <file name>	(In print server mode) The specified log file has been opened.
papd start. (AppleTalk)	AppleTalk print service has started.
permission denied.	Job cancellation was determined to be unauthorized after checking the user name and host address (except for ROOT authorization).
phy release file open failed.	Replacing the Network Interface Board is required. Contact your sales or service representatives.
Print queue <print queue name> cannot be serviced by printer 0, <print server name>	(In print server mode) The print queue name cannot be serviced. Make sure that print queue volume exists on the specified file server.
Print server <print server name> has no printer.	(In print server mode) The printer object is not assigned to the print server <print server name>. Using NWAdmin, assign the printer object, and then restart the printer device.
Print session full	Cannot accept the print session.

Message	Description and Solutions
Printer <printer name> has no queue	(In print server mode) The print queue is not assigned to the printer. Using NWAdmin, assign the print queue to the printer, and then restart it.
pserver start. (NetWare)	(In print server mode) NetWare service has started.
Required computer name (<Computer name>) is duplicated name	The same computer name is detected on the network. The start job determines the computer name by adding the computer name to the suffix (0,1,...). Configure a new computer name that is unique.
Required file server (<file server name>) not found	Cannot find the required file server.
restarted.	LPD has started.
sap enable, saptyp=<SAP type>, sapname=<SAP name>	The SAP function has started. The SAP (SAP type and SAP name) packet is issued to advertise the service on the SAP table on the NetWare server.
Set context to <NDS context name>	A <NDS context name> has been set.
shutdown signal received. network service rebooting...	Rebooting the network service.
smbd start. (NetBEUI)	An smbd (SMB (Server Message Block) service) has started.
Snmp over ip is ready.	Communication over TCP/IP with SNMP is available.
Snmp over IP over 1394 is ready.	Communication over IP over 1394 with SNMP is available.
Snmp over ipx is ready.	Communication over IPX with SNMP is available.
snmpd start.	SNMP service has started.
started.	Direct print service has started.
The print server received error <error number> during attempt to log in to the network. Access to the network was denied. Verify that the print server name and password are correct.	Cannot log in to the file server. The print server is not registered or the password is specified. Register the print server without specifying a password.
win2kspd protocol-DOWN (APPEXIT).	NVRAM setting ioctl (SPIO CAPPEXIT) of device SBP2TSP was set by protocol-DOWN. SCSI print is not receiving data.
win2kspd protocol-UP (APPENTRY).	NVRAM setting ioctl (SPIO CAPPEXIT) of device SBP2TSP was set by protocol-UP. SCSI print is not receiving data.

Message	Description and Solutions
win2kspd started.	SCSI print (SBP-2) service has started.
WINS name refresh :Server No Response	There has been no response to the update request from the server. Confirm that the WINS server address is correct and the WINS server is working properly.
WINS name registration:Server No Response	There has been no response to the registration request from the server. Confirm that the WINS server address is correct and the WINS server is working properly.
WINS server address0.0.0.0	The WINS server address has not been specified. Specify the WINS server address to match the printer name with WINS.
WINS Server=< WINS server address > NetBIOS Name=<NetBIOS name>	The printer name has been successfully registered in <WINS server address>.
WINS wrong scopeID	The scope ID is wrong. Specify the correct scope ID.
write error occurred. (diskfull)	The hard disk became full while the spool file was being written. Wait until enough HDD space becomes available as printing proceeds.
write error occurred. (fatal)	A fatal error occurred while the spool file was being written. Turn the printer off and then on. If this does not work, contact your service or sales representative.

Precautions

Please pay attention to the following when using the Network Interface Board. When configuration is necessary, follow the appropriate procedures below.

Connecting a Dial-Up Router to a Network

When the NetWare file server and the printer are on the opposite side of a router, packets are continuously sent back and forth, possibly causing communications charges to increase. Because the packet transmission is a specification of NetWare, you need to change the configuration of the router. If the network you are using does not allow you to configure the router, configure the machine.

Configuring the router

Filter the packets so that they do not pass over the dial-up router.

 **Note**

- The MAC address of the printer doing the filtering is printed on the printer configuration page. For more information about printing a configuration page, see the Setup Guide.
- For more information about configuring the printer if the router cannot be configured, see the instructions below.

Configuring the printer with NetWare

- 1** Following the setup method in this manual, configure the file server.
- 2** Set the frame type for a NetWare environment.

 **Reference**

For more information about selecting a frame type, see the Setup Guide.

Configuring the printer without NetWare

- 1** While not printing, the Network Interface Board sends packets on the network. Set the NetWare to inactive.

 **Reference**

For more information about selecting a protocol, see the Setup Guide.

PostScript Printing from Windows

When printing PostScript from Windows, see the PostScript 3 Operating Instructions Supplement provided as a PDF file on the CD-ROM labeled “Operating Instructions”.

NetWare Printing

Form Feed

You should not configure the form feed on NetWare. The form feed is controlled by the printer driver on Windows. If the NetWare form feed is configured, the printer might not work properly. If you want to change the form feed setting, always configure it on Windows.

- With Windows 95/98/Me, clear the **[Form feed]** check box on the **[Printer Settings]** tab in the printer properties dialog box.
- With Windows 2000, clear the **[Form feed]** check box on the **[NetWare Settings]** tab in the printer properties dialog box.
- With Windows NT 4.0, clear the **[Form feed]** check box on the **[NetWare Settings]** tab in the printer properties dialog box.

7

Banner Page

You should not configure a banner page on NetWare. If you want to change the banner page setting, always configure it on Windows.

- With Windows 95/98/Me, clear the **[Enable banner]** check box on the **[Printer Settings]** tab in the printer properties dialog box.
- With Windows 2000, clear the **[Enable banner]** check box on the **[NetWare Settings]** tab in the printer properties dialog box.
- With Windows NT 4.0, clear the **[Enable banner]** check box on the **[NetWare Settings]** tab in the printer properties dialog box.

Printing after resetting the machine

After resetting the remote printer, the connection from the print server will be cut off for about 30-40 seconds before re-connecting. Due to the NetWare specification, print jobs may be accepted, but they will not be printed during this interval.

When using the machine as a remote printer, wait about 2 minutes after resetting the printer before attempting to print.

Using DHCP

You can use the printer under a DHCP environment. You can also register the printer NetBIOS name on a WINS server when it is running.

Limitation

- DHCP cannot be used with IEEE 1394 (IP over 1394). Set a fixed IP address with the control panel, telnet or a Web browser.
 - See the Setup Guide.
 - See p.93 “TCP/IP address”.
 - See p.78 “Configuring the Network Interface Board Settings”.

Note

- Printers that register the printer NetBIOS name on a WINS server must be configured for the WINS server. See p.105 “WINS”.
- Supported DHCP server is Windows NT 4.0 Server Service Pack 4 or later, Windows 2000 Server and NetWare 5.
- If you do not use the WINS server, reserve the printer's IP address in the DHCP server so that the same IP address is assigned every time.
- DHCP relay-agent is not supported. If you use DHCP relay-agent on a network via an ISDN line, it will result in expensive line charges. This is because your computer connects to the ISDN line whenever a packet is transferred from the printer.

Using AutoNet

If the printer IP address is not assigned by a DHCP server automatically, a temporary IP address starting with 169.254 which is not used on the network can be selected automatically by the printer.

Note

- The IP address assigned by the DHCP server is given priority to that selected by AutoNet.
- You can confirm the current IP address on the configuration page. For more information about the configuration page, see the Printer Reference.
- When AutoNet is running, the NetBIOS name is not registered on the WINS server.

Configuring a WINS Server

The printer can be configured to register its NetBIOS name with a WINS server when power is turned on. This enables the NetBIOS name of the printer to be specified from SmartNetMonitor for Admin even under a DHCP environment.

This section describes how to configure the WINS server.

Note

- The WINS Server is supported with Windows NT 4.0 Server Service Pack 4 or later, and Windows 2000 Servers WINS Manager.
- For more information about the WINS Server settings, see Windows Help.
- If there is no reply from the WINS Server, the NetBIOS name will be registered by broadcast.
- The NetBIOS name consists of up to 13 alphanumeric characters.

Using a WWW browser

1 Start the Web browser.

2 Point your browser at the URL or IP address of the printer (e.g. `http://XXX.XXX.XXX.XXX` where the Xs are the number of the IP address).

The status of the printer you chose appears on the Web browser.

3 Click Network Config.

The dialog box for entering the password and user name is displayed.

4 Enter your user name and password, and then click OK.

To use the factory default account, enter no user name and type "password" for the password.

5 Click TCP/IP.

6 Set WINS to active and enter the IP address of the WINS server in Primary WINS Server and Secondary WINS Server.

7 Click Refresh.

8 Exit the Web browser.

Using telnet

1 Connect to the remote printer using telnet.

2 Use the "set" command to make WINS active.

```
msh> set wins on
```

3 Specify the IP addresses (primary and secondary) using the following commands.

```
msh> wins primary Ipaddress msh> wins secondary Ipaddress
```

 **Note**

To confirm the current configuration, use the "show" command.

4 Log out from telnet.

When Using the NIB Setup Tool

If the Network Interface Board cannot browse using the TCP/IP protocol, make sure that the TCP/IP environment is correctly configured in your computer.

When Using IPP with SmartNetMonitor for Client

When using IPP with SmartNetMonitor for Client, note the following:

- The network printer can only receive one print job from SmartNetMonitor for Client at a time. While the network printer is printing a job, another user cannot access the network printer until it completes the job. In this case, SmartNetMonitor for Client tries to access the network printer until the retry interval expires.
- If SmartNetMonitor for Client cannot access the network printer and times out, SmartNetMonitor for Client stops sending the print job. In this case, you should cancel the paused status from the print queue window. SmartNetMonitor for Client will resume access to the network printer. You can delete the print job from the print queue window, but canceling a print job that has been printed by the network printer might cause the next print job sent from another user to be incorrectly printed.
- If a print job that is sent from SmartNetMonitor for Client is interrupted and the network printer cancels the job because something went wrong, launch the print job again.
- Print jobs sent from another computer do not appear in the print queue window regardless of the protocol.
- If various users send print jobs using SmartNetMonitor for Client to network printers, the printing order might not be in the order in which the jobs were sent.
- An IP address cannot be used for the IPP port name because the IP address is used for the SmartNetMonitor for Client port name.

Specifications

Interface	100BASE-TX, 10BASE-T, IEEE 1394 (IP over 1394) ^{*1} , IEEE 802.11b
Frame type	EthernetII, IEEE 802.2, IEEE 802.3, SNAP
Protocol	<ul style="list-style-type: none"> • TCP/IP Windows 95 Windows 98 Windows Me Windows 2000 Windows XP Windows NT 4.0 • IPX/SPX NetWare 3.12, 3.2, 4.1, 4.11, 4.2, 5, 5.1 IntranetWare • NetBEUI ^{*2} Windows 95 Windows 98 Windows Me Windows 2000 Windows NT 4.0 • IPP Windows 95 Windows 98 Windows Me Windows 2000 Windows XP Windows NT 4.0 • AppleTalk Mac OS 8.6 or later (Mac OS X Classic environment is supported.)
SNMP	MIB-II, PrinterMIB, HostResourceMIB, RicohPrivateMIB

^{*1} The 1394 Interface Unit 4510 supports TCP/IP and IPP.

^{*2} To use NetBEUI, use the SmartNetMonitor for Client port.

INDEX

A

Access Control, 95
AutoNet, 121
 telnet, 105

B

BOOT, 95

C

Changing Names and Comments, 81
 SmartNetMonitor for Admin, 81
 Web Browser, 83
client computer, setup
 Windows 2000, 23
 Windows 95/98/Me, 10
 Windows NT 4.0, 47
 Windows XP, 35
community name, 98
configuration
 LPR port printing, Windows 2000, 22
 LPR port printing, Windows NT 4.0, 46
 LPR port printing, Windows XP, 34
 Macintosh, 71
 NetWare, 49
 NetWare 3.x, 54
 NetWare 4.x, 5/5.1, 60
 Web Browser, 76
 Windows 2000, 13
 Windows 95/98/Me, 1
 Windows NT 4.0, 37
 Windows XP, 25
Configuring, 81

D

DHCP, 95, 121
dial-up router, 119
Direct Printing Port, 100
Displaying the Status of Printer, 84
 SmartNetMonitor for Admin, 84
 SmartNetMonitor for Client, 85
 Web Browser, 86

E

EtherTalk, 71

H

Host Name, 104

I

IEEE 802.11b, 102
information
 Network Interface Board configuration,
 97, 110
 print job, 109
 print log, 109
 system log, 97, 113
install
 NIB Setup Tool, 49
 SmartNetMonitor for Client, Windows
 2000, 18
 SmartNetMonitor for Client, Windows
 95/98/Me, 6
 SmartNetMonitor for Client, Windows
 NT 4.0, 42
 SmartNetMonitor for Client, Windows
 XP, 30
IP address, 93
IPP, 99, 123

J

Job Spool
 telnet, 103

L

LAN adapter number (Lana Number), 39
LPR port printing, 22, 34, 46

M

Macintosh, 71
message, 113
MIB, 108
Monitoring, 81

N

- NetWare, 49
- NetWare 3.x, 54
- NetWare 4.x, 5, 60
- network boot, 95
- NIB Setup Tool, 51
 - install*, 49
 - install, SmartNetMonitor for Admin*, 50
 - precautions*, 123
 - Run NIB Setup Tool*, 50

P

- password, 77, 107
- precautions, 119
- printer name, 72
- printer status, 96
- Pure IP, 63

R

- remote printer, setup
 - NetWare 3.x*, 57
 - NetWare 4.x, 5/5.1*, 65
- ROUTE, 101

S

- setup
 - client computer, Windows 2000*, 23
 - client computer, Windows 95/98/Me*, 10
 - client computer, Windows NT 4.0*, 47
 - client computer, Windows XP*, 35
- SLP, 102
- SmartNetMonitor for Client, 123
 - Windows 2000*, 17
 - Windows 95/98/Me*, 5
 - Windows NT 4.0*, 41
 - Windows XP*, 29
- SmartNetMonitor for Client, *delete the port*
 - Windows 2000*, 18
 - Windows 95/98/Me*, 6
 - Windows NT 4.0*, 42
 - Windows XP*, 30
- SmartNetMonitor for Client, *install*
 - Windows 2000*, 18
 - Windows 95/98/Me*, 6
 - Windows NT 4.0*, 42
 - Windows XP*, 30

- SmartNetMonitor for Client, *printer port*
 - Windows 2000*, 19
 - Windows 95/98/Me*, 7
 - Windows NT 4.0*, 43
 - Windows XP*, 31

- SmartNetMonitor for Client, *uninstall*
 - Windows 2000*, 19
 - Windows 95/98/Me*, 6
 - Windows NT 4.0*, 42
 - Windows XP*, 31

- SMB, 101
- SNMP, 97, 108
- sntp, 106
- specifications, 124
- subnet mask, 94

T

- telnet, 92
 - AutoNet*, 105
 - WINS, 105

U

- uninstall
 - SmartNetMonitor for Client, Windows 2000*, 19
 - SmartNetMonitor for Client, Windows 95/98/Me*, 6
 - SmartNetMonitor for Client, Windows NT 4.0*, 42
 - SmartNetMonitor for Client, Windows XP*, 31
- Using SmartNetMonitor for Admin, 73

W

- Web Browser, 76
- Windows 2000, 13
- Windows 95/98/Me, 1
- Windows NT 4.0, 37
- Windows XP, 25
- WINS, 122
 - telnet*, 105

Z

- zone, 72



Network Printing Guide





PostScript 3

Operating Instructions Supplement

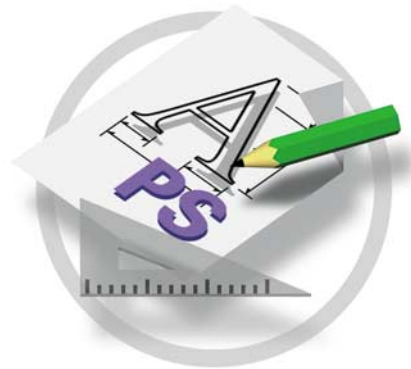

For safety, please read this manual carefully before you use this product and keep it handy for future reference.

Introduction

To get maximum versatility from this machine all operators should carefully read and follow the instructions in this manual. Please keep this manual in a handy place near the printer.

Please read the Safety Information before using this printer. It contains important information related to USER SAFETY and PREVENTING EQUIPMENT PROBLEMS.

Important

Contents of this manual are subject to change without prior notice. In no event will the company be liable for direct, indirect, special, incidental, or consequential damages as a result of handling or operating the machine.

Trademarks

Microsoft®, Windows® and Windows NT® are registered trademarks of Microsoft Corporation in the United States and/or other countries.

Adobe® and PostScript® are registered trademarks of Adobe Systems Incorporated.

Appletalk, Apple, Macintosh is a registered trademark of Apple Computer, Incorporated.

Other product names used herein are for identification purposes only and might be trademarks of their respective companies. We disclaim any and all rights in those marks.

Notes:

Some illustrations in this manual might be slightly different from the machine.

Certain options might not be available in some countries. For details, please contact your local dealer.

TABLE OF CONTENTS

1. Using PostScript 3

Setting up Options	1
Job Type	1
Collate	6
Duplex Printing.....	6
Paper Selection.....	7
Paper Size.....	8
Media Type	8
Paper source.....	8
Destination Tray.....	9
Resolution	9
Toner Saver	9
User Code.....	10
Options.....	10

2. Printer Utility for Mac

Installing Printer Utility for Mac	13
Starting Printer Utility for Mac.....	14
Printer Utility for Mac Functions.....	15
Downloading PS Fonts.....	16
Displaying Printer's Fonts.....	17
Deleting Fonts.....	17
Initializing the Printer Disk.....	18
Page Setup	18
Printing Font Catalog	18
Printing Font Sample.....	19
Renaming the Printer	19
Restarting the Printer	20
Downloading PostScript Files	20
Selecting the Zone	20
Displaying the Printer Status.....	21
Launching the Dialogue Console	21
INDEX.....	23

1. Using PostScript 3

Setting up Options

This documentation describes the specific printer functions and menus that are added by installing the PPD file. For more information about the functions and menus of the Windows 95/98/Me PostScript printer driver, see the printer driver's Help.

Job Type

Use this to select the type of print job.

The following table shows the tabs or menus where you can select this function.

Windows 95/98/Me	[Job Type] on the [Setup] tab.
Windows 2000/Windows XP	[Job Type] on the [Job/Log] tab in the Printing Preferences Properties.
Windows NT 4.0	[Job Type] on the [Job/Log] tab in the Document Defaults dialog box.
Macintosh	[Job Type] on [Job Log] in the print dialog box.

You can select the following items.

❖ Normal

Select this for normal printing. The print job starts immediately after the print command is given.

Note

- If you want to use an User ID, click the [Detail] button.

❖ Sample Print

Use this function to print only one set of a multiple print jobs.

The other sets are saved in the machine. The saved job can be printed from the machine's control panel. You can also delete the saved job.

Limitation

- To use this function, the optional Hard Disk Drive must be installed on the printer.

Note

- The "User ID" can consist of up to eight alphanumeric (a-z, A-Z, 0-9) characters.
- Entering the "User ID" helps you to distinguish the print job from others.

Reference

For more information about how to use Sample Print, see p.2 "How to Use Sample Print".

❖ **Locked Print**

Use this function to save documents in the machine memory with a password, and then edit and print them as you want.

📌 **Limitation**

- To use this function, the optional Hard Disk Drive must be installed on the printer.

📝 **Note**

- The "User ID" can consist of up to eight alphanumeric (a-z, A-Z, 0-9) characters. The "Password" must be four digits.

🔍 **Reference**

For more information about how to use Locked Print, see p.4 "How to Use Locked Print".

How to Use Sample Print

Follow the procedures to print a document using the "Sample Print" function.

📝 **Note**

- If the application has a collate option, make sure that it is not selected before sending a print job. By default, sample print jobs are automatically collated by the printer driver. If the collate option is selected in the application print dialog box, more prints than intended may be printed.

Windows 95/98/Me

1 From an application, select the menu command to print.

The print dialog box appears.

2 Open the Printer Properties to set the Sample Print.

3 Click to select the [Setup] tab.

4 Select [Sample Print] in [Job Type].

5 Click [Details...].

6 Enter the "User ID" in [User ID]. This can consist of up to eight alphanumeric (a- z, A- Z, 0- 9) characters.

📝 **Note**

- Select this to identify the user associated with the job.

7 Click [OK].

Windows 2000/Windows XP, Windows NT 4.0

- 1** From an application, select the menu command to print.

The print dialog box appears.

- 2** Open the Printer Properties to set the Sample Print.

- 3** Click to select the [Job/ Log] tab.

- 4** Select [Sample Print] in [Print Job].

- 5** Enter the "User ID" in [User ID]. This can consist of up to eight alphanumeric (a- z, A- Z, 0- 9) characters.

 **Note**

Select this to identify the user associated with the job.

- 6** Click [OK] to close the Printer Properties.

- 7** Start printing from the application's print dialog box.

The Sample Print job is sent to the machine and one set is printed.

- 8** Check the sample print to confirm that the settings are correct.

If the settings are correct, see "*Printing a Sample Print File*" in the Printer Reference.

If not, you can delete the saved job. See "*Deleting a Sample Print File*" in the Printer Reference.

Macintosh

- 1** From an application, select the menu command to print.

The print dialog box appears.

- 2** Click to select [Job Log] from the pop up menu.

- 3** Select [Sample Print] in [Job Type], and then select the appropriate setting.

- 4** Enter the "User ID" in [User ID]. This can consist of up to eight alphanumeric (a-z, A-Z, 0-9) characters.

 **Note**

This is used to identify the user associated with a job.

The "User ID" can consist of up to eight alphanumeric (a-z, A-Z, 0-9) characters.

- 5** After making all of the settings you want, click [Print].

The Sample Print job is sent to the machine and one set is printed.

6 Check the sample print to confirm that the settings are correct.

If the settings are correct, see "Printing a Sample Print File" in the Printer Reference.

If not, you can delete the saved job. See "Deleting a Sample Print File" in the Printer Reference.

How to Use Locked Print

Follow the procedures to print a document using the "Locked Print" function.

 **Note**

- If the application has a collate option, make sure that it is not selected before sending a print job. By default, locked print jobs are automatically collated by the printer driver. If the collate option is selected in the application print dialog box, more prints than intended may be printed.

Windows 95/98/Me

1 From an application, select the menu command to print.

The print dialog box appears.

2 Open the Printer Properties to set the locked print.

3 Click to select the [Setup] tab.

4 Select [Locked Print] in [Job Type].

5 Click [Details...].

6 Enter the "User ID" in [User ID]. This can consist of up to eight alphanumeric (a-z, A-Z, 0-9) characters. Then enter a password in [Password], up to four digits.

 **Note**

- Select this to identify the user associated with the job.

7 Click [OK].

Windows 2000/Windows XP, Windows NT 4.0

1 From an application, select the menu command to print.

The print dialog box appears.

2 Open the Printer Properties to set the locked print.

3 Click to select the [Job/ Log] tab.

- 4** Select **[Locked Print]** in **[Print Job]**.
- 5** Enter the "User ID" in **[User ID]**. This can consist of up to eight alphanumeric (a-z, A-Z, 0-9) characters. Then enter a password in **[Password]**, up to four digits.

 **Note**

- Use this to identify the user associated with the job.

- 6** Click **[OK]** to close the **Printer Properties**.
- 7** Start printing from the application's print dialog box.
The Locked Print job is sent to the machine.

Macintosh

- 1** From an application, select the menu command to print.
The print dialog box appears.
- 2** Click to select **[Job Log]** from the pop up menu.
- 3** Select **[Locked Print]** in **[Job Type]**, and then select the appropriate setting.
- 4** Enter the "User ID" in **[User ID]**. This can consist of up to eight alphanumeric (a-z, A-Z, 0-9) characters. Then enter a password in **[Password]**, up to four digits.

 **Note**
 - This is used to identify the user associated with a job.
- 5** After making all of the settings you want, click **[Print]**.

Collate

Use this function to enable collation. With this feature, the printer can efficiently print collated sets of multiple-page documents.

! Limitation

- To use this function, the optional Memory Unit of 96MB in total or Hard Disk Drive must be installed on the printer.
- If you select Upper Tray as an output tray, it is shift collated automatically.

The following table shows the tabs or menus where you can select this function.

Windows 95/98/Me	[Collate] on the [Setup] tab.
Windows 2000/Windows XP	[Printer Features] on [Advanced...] on the [Paper/Quality] tab in the Printing Preferences Properties.
Windows NT 4.0	[Printer Features] on [Document Options] on the [Advanced] tab.
Macintosh	[Collate:] on [Printer Specific Options] in the print dialog box.

Duplex Printing

Use this function to select duplex printing.

! Limitation

- To use this function, the optional Duplex Unit must be installed on the printer.

The following table shows the tabs or menus where you can select this function.

Windows 95/98/Me	[Duplex] on the [Setup] tab.
Windows 2000/Windows XP	[Print on Both Sides (Duplex)] on the [Layout] tab in the Printing Preferences Properties.
Windows NT 4.0	[Print on Both Sides (Duplex Printing)] on the [Page Setup] tab in the Document Defaults dialog box.
Macintosh	[Print on Both Sides] on [Layout] in the print dialog box.

You can select the following items. The following items may vary depending on the operating system you are using.

Windows 95/98/Me

❖ Off

Disables Duplex Printing.

❖ Open to Left

Prints output so that you can open it to the left when bound along the left edge.

❖ Open to Top

Prints output so that you can open it to the top when bound along the top edge.

Windows 2000/Windows XP, Macintosh

 **Note**

- When you use the Macintosh, click to select the button that means **[Flip on Long Edge]** or **[Flip on Short Edge]**.

❖ None

Disables Duplex Printing.

❖ Flip on Short Edge

Prints output so that you can open it to the short edge when bound along the short edge.

❖ Flip on Long Edge

Prints output so that you can open it to the long edge when bound along the long edge.

Windows NT 4.0

 **Note**

- When you use the Macintosh, click to select the button that means **[Flip on Long Edge]** or **[Flip on Short Edge]**.

❖ Short Side

Prints output so that you can open it to the short edge when bound along the short edge.

❖ Long Side

Prints output so that you can open it to the long edge when bound along the long edge.

Paper Selection

Paper Sources and Output Tray Tabs

Use this to select the media type, input tray, and output tray on the following tabs.

 **Limitation**

- This function is for Windows 95/98/Me only.

 **Reference**

For more information about the **[Paper Sources and Output Tray]** tabs. See the Help file for the printer driver.

Paper Size

Use this to select the size of paper you want to use.

The following table shows the tabs or menus where you can select this function.

Windows 95/98/Me	[Size:] on the [Paper] tab.
Windows 2000/Windows XP	[Paper/Output] on [Advanced...] on the [Paper/Quality] tab in the Printing Preference Properties.
Windows NT 4.0	[Paper Size:] on the [Page Setup] tab in the Document Defaults.
Macintosh	[Paper:] on the [Page Attributes] tab in the Page Setup dialog box.

Reference

For more information about the paper sizes supported by this printer, see "*Paper and Other Media Supported by This Printer*" in the Printer Reference.

Media Type

Use this to select the paper type.

The following table shows the tabs or menus where you can select this function.

Windows 95/98/Me	[Type:] on [All Pages] on the [Paper] tab.
Windows 2000/Windows XP	[Media:] on the [Paper/Quality] tab in the Printing Preference Properties.
Windows NT 4.0	[Paper/Output] on the [Advanced] tab in the Document Defaults.
Macintosh	[Paper Type:] on [Printer Specific Options] in the print dialog box.

Reference

For more information about the media type supported by this printer, see "*Paper and Other Media Supported by This Printer*" in the Printer Reference.

Paper source

Use this to select the paper sources.

The following table shows the tabs or menus where you can select this function.

Windows 95/98/Me	[All Pages] on the [Paper] tab.
Windows 2000/Windows XP	The [Paper/Quality] tab in the Printing Preferences Properties.
Windows NT 4.0	The [Page Setup] tab.
Macintosh	[Paper Source:] on [General] in the print dialog box.

Destination Tray

Use this to select the output tray.

The following table shows the tabs or menus where you can select this function.

Windows 95/98/Me	[Destination] on the [Paper] tab.
Windows 2000/Windows XP	[Printer Features] on [Advanced...] on the [Paper/Quality] tab in the Printing Preferences Properties.
Windows NT 4.0	[Printer features] on [Document Options] on the [Advanced] tab.
Macintosh	[Destination:] on [Printer Specific Options] in the print dialog box.

Resolution

Use this to set the resolution to **[600dpi]** or **[1200dpi]**.

The following table shows the tabs or menus where you can select this function.

Windows 95/98/Me	[Advanced] on the [Print Quality] tab
Windows 2000/Windows XP	[Printer Features] on [Advanced...] on the [Paper/Quality] tab in the Printing Preferences Properties
Windows NT 4.0	[Printer Features] on [Document Options] on the [Advanced] tab
Macintosh	[Printer Specific Options] in the print dialog box

Toner Saver

Use this function to reduce the amount of toner used when printing.

The following table shows the tabs or menus where you can select this function.

Windows 95/98/Me	[Toner Saver] on the [Print Quality] tab.
Windows 2000/Windows XP	[Printer Features] on [Advanced...] on the [Paper/Quality] tab in the Printing Preferences Properties.
Windows NT 4.0	[Printer Features] on [Document Options] on the [Advanced] tab.
Macintosh	[Toner Saver:] on [Printer Specific Options] in the print dialog box.

Note

- When you use Windows 2000/Windows XP/NT 4.0, this function is called "Toner Saving".

User Code

Use this to set a user code for print logging.

Enter a user code using up to eight digits. A user code identifies a group of users and allows you to check the number of sheets printed under each code with SmartNetMonitor for Admin.

The following table shows the tabs or menus where you can select this function.

Windows 95/98/Me	[User Code] on the [Statistics] tab.
Windows 2000/Windows XP	[User Code] on the [Job/ Log] tab in the Printing Preferences Properties.
Windows NT 4.0	[User Code] on the [Job/ Log] tab in the Document Defaults dialog box.
Macintosh	[User Code] on [Job Log] in the print dialog box.

Reference

For more information about using SmartNetMonitor for Admin, see the Help file.

Options

See “Setting Up Options” in the Setup Guide for the installation method appropriate to your printing environment.

The following table shows the tabs or menus where you can select this function.

Windows 95/98/Me	[Option] on the [Accessories] tab.
Windows 2000/Windows XP	[Installable Options] on the [Device Setting] tab.
Windows NT 4.0	[Option] on the [Device Setting] tab.
Macintosh	[Chooser] on the Apple Menu.

❖ Tray 2

- You can select the tray with the following menu for Paper Feed Unit Type 2600:
Paper Source ⇒ p.8

❖ Tray 3

- You can select the other tray with the following menu for an additional Paper Feed Unit Type 2600:
Paper Source ⇒ p.8

❖ Duplex Unit

- You can use the following function with AD410:
“Duplex Printing” ⇒ p.6

❖ Hard Disk

- You can use the following function with Hard Disk Drive Type 2600:
Collate⇒ p.6
Job Type⇒ p.1

❖ Mailbox** Note**

- The optional Mailbox and Upper Tray can not be installed at the same time.
- You can select the following menu for CS380:
Destination⇒ p.9

❖ Upper Tray** Note**

- The optional Mailbox and Upper Tray can not be installed at the same time.
- You can select the following menu for 1-bin Shift Sort Tray Type 2600:
Destination⇒ p.9

❖ Total Memory

- You can use the following function with Memory Unit TypeB 64MB:
Collate⇒ p.6

2. Printer Utility for Mac

By using Printer Utility for Mac, you can download fonts, change the name of the printer and so on.

Limitation

- If a Macintosh and printer are connected by USB, you cannot use Printer Utility for Mac.

Note

- Printer Utility for Mac is included on the CD-ROM labeled “Drivers and Utilities”.
- Printer Utility for Mac requires Mac OS 8.1 or later. (Mac OS X Classic environment is supported.)

Installing Printer Utility for Mac

Follow these steps to install Printer Utility for Mac on the machine.

1 Start the Macintosh.

2 Insert the CD-ROM into the CD-ROM drive.

The CD-ROM icon appears.

3 Double-click the icon of hard disk to open it.

4 Double-click the CD-ROM icon.

The contents of the CD-ROM appear.

5 Double-click the [PS Utility] folder on the CD-ROM, and then drag the [Printer Utility for Mac] file, and then drop it into the Macintosh hard disk.

6 Drag the CD-ROM icon and drop it into [Trash] to eject the CD-ROM.

Printer Utility for Mac is installed.

Starting Printer Utility for Mac

The following instructions describe how to start Printer Utility for Mac.

Important

- Before starting Printer Utility for Mac, confirm that the printer is selected with **[Chooser]** on the Apple menu.

2

1 Double-click the icon of **Printer Utility for Mac**.

The Printer Utility for Mac dialog box appears.

2 Click **[OK]**.

Printer Utility for Mac will take a few seconds to start.

Reference

For more information, see “Printer Utility for Mac Functions”.

Printer Utility for Mac Functions

Printer Utility for Mac functions are described below.

❖ File menu

- **[Download PS Fonts...]**
Download fonts (PostScript Type 1) to the printer. See p.16 “Downloading PS Fonts”.
- **[Display Printer's Fonts...]**
Display and delete the fonts in printer memory and the printer's hard disk drive. See p.17 “Displaying Printer's Fonts”.
- **[Initialize Printer's Disk...]**
Initialize the printer's hard disk drive. See p.18 “Initializing the Printer Disk”.
- **[Page Setup...]**
Set up the paper size to print “Printer Font Catalog” and “Printer Font Sample”. See p.18 “Page Setup”.
- **[Print Font Catalog...]**
Print the names of available fonts. See p.18 “Printing Font Catalog”.
- **[Print Font Sample...]**
Print a sample of fonts. See p.19 “Printing Font Sample”.
- **[Rename Printer...]**
Change the printer's name when viewed via Appletalk. See p.19 “Renaming the Printer”.
- **[Restart Printer]**
Restart the printer. See p.20 “Restarting the Printer”.

❖ Utility menu

- **[Download PostScript File...]**
Download a PostScript File. See p.20 “Downloading PostScript Files”.
- **[Select Zone...]**
Change the zone the printer belongs to via Appletalk. See p.20 “Selecting the Zone”.
- **[Display Printer Status...]**
Display the status of the printer. See p.21 “Displaying the Printer Status”.
- **[Launch Dialogue Console...]**
Create and edit a PostScript file, and download it to the printer. See p.21 “Launching the Dialogue Console”.

Downloading PS Fonts

You can download the PS fonts to the printer's memory or hard disk drive.

Important

- The following procedures to download the fonts assume that you are a system administrator. If you are not, be sure to consult your system administrator.
- If the printer restarts, all the printer settings return to their defaults.
- Confirm that Macintosh and the printer are connected with Appletalk.

Note

- Some fonts cannot be downloaded.
- Before downloading, read the documentation about the fonts you want to use.

1 Select **[Download PS Fonts...]** on the **[File]** menu.

2 Click **[Add to list]**.

The dialog box to select fonts appears.

3 Click to select the desired font files, and then click **[Open]**.

The list of selectable font names appears.

4 After adding all the fonts you want to download, click **[OK]**.

The dialog box of selected fonts to download appears.

5 Click **[Download]**.

The fonts begin to download, and the download status is shown.

Important

- During the download, do not turn off the power switch, operate the panel or open or close the cover.

6 When the completion message appears, click **[OK]**.

7 Click **[Cancel]**.

Displaying Printer's Fonts

You can display the available fonts currently downloaded to the printer. Fonts in the printer's memory and hard disk drive can be displayed.

Note

The fonts displayed in italics are the default fonts.

1 Select **[Display Printer's Fonts...]** on the **[File]** menu.

A dialog box appears.

2 Select **[Printer's memory]** or **[Printer's disk]**.

3 Click **[OK]**.

Deleting Fonts

You can delete fonts from the printer's memory or hard disk drive.

1 Select **[Display Printer's fonts]** on the **[File]** menu.

A dialog box appears.

2 Select **[Printer's memory]** or **[Printer's disk]**.

3 Select the fonts you want to delete.

Limitation

You cannot delete the fonts displayed in italic.

4 Click **[Delete]**.

A confirmation message appears.

5 Confirm the fonts you want to delete and the printer name from which you want to delete the fonts.

6 Click **[Continue]**, and then click **[OK]**.

7 Click **[OK]**.

Initializing the Printer Disk

When initializing the printer's hard disk, all the fonts downloaded to the printer's hard disk drive are deleted. Before initializing, be sure to check the fonts on the hard disk drive.

Important

- When initializing the printer's hard disk drive from the operation panel, all of the data on the printer's hard disk drive is deleted. Before initializing, be sure to check the data on the hard disk drive.

1 Select [Initialize Printer's Disk...] on the [File] menu.

The confirmation message appears.

Note

- To cancel initialization, click [Cancel].

2 Click [Execute].

Initializing starts.

Important

- Do not turn off the power switch until initializing is completed, otherwise the hard disk drive might be damaged.

3 When the completion message appears, click [OK].

Page Setup

You can set the paper size on which to print "Print Fonts Catalogue" and "Prints Fonts Sample".

1 Select [Page Setup...] on the [File] menu.

2 Choose the paper size.

Printing Font Catalog

Print the names of fonts available on the printer.

Note

- The paper selected under [Page Setup] is used.

1 Select [Print Fonts Catalogue] on the [File] menu.

2 Click [Print].

Printing Font Sample

You can print samples of fonts downloaded to the hard disk drive or memory.

 **Note**

Print by using the paper selected on [Page Setup].

1 Select [Print Fonts Sample...] on the [File] menu.

2 Click [Print].

Renaming the Printer

You can change the printer's name displayed under Appletalk. If you connect several printers on the network, assign different names so you can identify them. If several printers have the same name, a digit appears next to the printer name in [Chooser].

1 Select [Rename Printer...] on the [File] menu.

2 Type a new name in the [New Name:] field.

 **Limitation**

You can enter up to 31 digits and letters.

Do not use symbols, for example "*", ":", "=", "@", "~".

3 Click [Rename].

The printer name is changed.

4 Press [OK].

5 Select [Chooser] on the Apple menu.

6 Click the [AdobePS] icon.

7 Click to select the printer name renamed in step **2**, and then close [Chooser].

 **Note**

If there are several Appletalk zones, select the zone the printer belongs to.

Restarting the Printer

You can restart the printer.

- 1** Select **[Restart Printer]** on the **[File]** menu.
- 2** Confirm the message that appears on the screen, and then click **[Restart]**.

The printer restarts.

 **Note**

- The fonts that you downloaded in the printer's memory will be deleted.
- If the printer restarts, all the printer settings return to their defaults.

Downloading PostScript Files

You can download a Postscript file to the printer.

- 1** Select **[Download PostScript File...]** on the **[Utility]** menu.
- 2** Select the file name to download and click the file name, and then click **[Open]**.
- 3** Type the log file name, and then click **[Save]**.

The selected file is downloaded.

 **Note**

- Errors are recorded in the log file.

Selecting the Zone

You can change the zone to which the printer belongs under Appletalk.

 **Important**

- Confirm that the printer and a Macintosh are connected in an Appletalk environment.

- 1** Select **[Select Zone...]** on the **[Utility]** menu.
The zone to which the printer belongs and the available zone list appear.
- 2** Select the zone to which you want to switch the printer, and then click **[Change]**.
A confirmation message appears.
- 3** Click **[Continue]**.
A confirmation message appears.

- 4** Press [OK].
- 5** Select [Chooser] on the Apple menu.
- 6** Click the [AdobePS] icon.
- 7** Select the zone selected in step **2** on the [Appletalk zone:] list.
- 8** Click to select the printer you want to use on the [Select a PostScript Printer:] list.
- 9** Close [Chooser].

Displaying the Printer Status

You can display and confirm the current status of the printer.

- 1** Select [Display Printer Status...] on the [Utility] menu.
The current status of the printer appears.

- 2** Confirm the current status of the printer.

You can confirm the memory capacity, the VM (Virtual Memory) space, the hard disk drive status and available space on the hard disk drive. You can also confirm the zone to which the printer belongs.

- 3** Click [OK].

Launching the Dialogue Console

You can create and edit a PostScript file for printing, and download it to the printer.

Important

- “Launch Dialogue Console” is recommended for users with an understanding of PostScript.
- Do not download any file other than PostScript files to the printer.
- “Launch Dialogue Console” must be used at your own responsibility.

- 1** Select [Launch Dialogue Console...] on the [Utility] menu.

Open the editing screen. The Dialogue Console menu bar appears.

- 2** Type the PostScript command in the editor screen.

Note

- To edit a PostScript file, select [Open] on the [File] menu to open it.
- You can search or replace a character string by using the [Search] menu.

- 3** After editing the PostScript file, select **[Download Top Window]** on **[Console]** menu to start printing.

The PostScript file is sent to the printer.

 **Note**

- The **[Reply from Printer]** box opens, depending on the PostScript file you sent.

2

- 4** Select **[Return To Main Menu]** on the **[Console]** menu to close the PostScript file.

INDEX

C

Collate, 6

D

Deleting Fonts, 17
Destination Tray, 9
Displaying Printer's Fonts, 17
Displaying the Printer Status, 21
Downloading PostScript Files, 20
Downloading PS Fonts, 16
Duplex Printing, 6

F

Functions
Printer Utility for Mac, 15

I

Initializing Printer Disk, 18
Installing, 13
Printer Utility for Mac, 13

J

Job Type, 1

L

Launching the Dialogue Console, 21

M

Media Type, 8

O

Options, 10

P

Page Setup, 18
Paper Selection, 7
Paper Size, 8
Paper source, 8
Printer Utility for Mac, 13
Functions, 15
Printing Font Catalog, 18
Printing Font Sample, 19

R

Renaming the Printer, 19
Resolution, 9
Restarting the Printer, 20

S

Selecting the Zone, 20
Setting up Options, 1

T

Toner Saver, 9

U

User Code, 10



UNIX Supplement

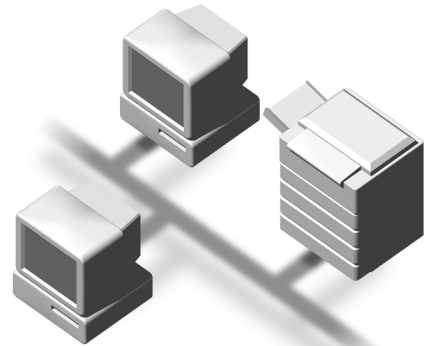

Read this manual carefully before you use this product and keep it handy for future reference.

For safety, please follow the instructions in this manual.

Introduction

To get maximum versatility from this machine all operators should carefully read and follow the instructions in this manual. Please keep this manual in a handy place near the machine.

Please read the Safety Information in the "Printer Reference" before using this machine. It contains important information related to USER SAFETY and PREVENTING EQUIPMENT PROBLEMS.

Important

Parts of this manual are subject to change without prior notice. In no event will the company be liable for direct, indirect, special, incidental, or consequential damages as a result of handling or operating the machine.

Further Information

Please consult your authorized reseller concerning additional UNIX support.

Trademarks

PostScript is a registered trademark of Adobe Systems, Incorporated.

PCL is a registered trademark of Hewlett-Packard Company.

Sun, SunOS, Solaris are trademarks or registered trademarks of Sun Microsystems, Inc. in the United States and other countries.

HP-UX is a registered trademark of Hewlett-Packard Company.

LINUX is a trademark of Linus Torvalds.

RED HAT is a registered trademark of Red Hat, Inc.

Other product names used herein are for identification purposes only and might be trademarks of their respective companies. We disclaim any and all rights in those marks.

Manuals for This Printer

The following manuals describe the operational procedures and maintenance of this machine.

To enhance safe and efficient operation of this printer, all users should read and follow the instructions carefully.

❖ **Quick Installation Guide**

Describes how to install the printer.

❖ **Setup Guide**

Provides information about setting up the printer and its options. This manual is provided as a printed manual, and also as a PDF file on the CD-ROM labeled "Operating Instructions".

❖ **Printer Reference**

Provides information about using the printer and its options. This manual provided as a PDF file on the CD-ROM labeled "Operating Instructions".

❖ **Network Interface Board Operating Instructions**

Provides information about setting up and using the printer in a network environment. This manual provided as a PDF file on the CD-ROM labeled "Operating Instructions".

❖ **PostScript 3 Operating Instructions Supplement**

Describes the menus and features for the PostScript 3 printer driver. This manual provided as a PDF file on the CD-ROM labeled "Operating Instructions".

❖ **UNIX Supplement (this manual)**

Provides information about setting up and using the printer in a UNIX environment. This manual provided as a PDF file on the CD-ROM labeled "Operating Instructions".

Note

- ❑ There are two CD-ROMs that come with this printer. One is labeled "Operating Instructions" and the other is "Drivers and Utilities".

How to Read This Manual

Symbols

In this manual, the following symbols are used:

WARNING:

This symbol indicates a potentially hazardous situation which, if instructions are not followed, could result in death or serious injury.

CAUTION:

This symbol indicates a potentially hazardous situation which, if instructions are not followed, may result in minor or moderate injury or damage to property.

* The statements above are notes for your safety.

Important

If this instruction is not followed, paper might be misfed, originals might be damaged, or data might be lost. Be sure to read this.

Preparation

This symbol indicates the prior knowledge or preparations required before operating.

Note

This symbol indicates precautions for operation, or actions to take after misoperation.

Limitation

This symbol indicates numerical limits, functions that cannot be used together, or conditions in which a particular function cannot be used.

Reference

This symbol indicates a reference.

[]

Keys that appear on the machine's panel display.

Keys and buttons that appear on the computer's display.

【 】

Keys built into the machine's operation panel.

Keys on the computer's keyboard.

TABLE OF CONTENTS

1. UNIX Configuration

- Using the Installation Shell Script 1**
 - Assigning the IP Address 1
 - Executing the Installation Shell Script 2
 - Setup 5
- Printing Method 10**
 - Printing with lpr, lp 10
 - Printing with rsh, rcp, ftp 11
- Printer Status 13**
 - Viewing the Printer Status with lpq and lpstat 13
 - Viewing the Printer Status with rsh and ftp 13
 - Copying Information to a File 14
- INDEX..... 15**

1. UNIX Configuration

This section explains how to set up a network printer and check the print status using UNIX.

Limitation

- To print from a UNIX workstation, use the file that the printer supports.

Using the Installation Shell Script

The installation shell script helps with the setup process. The installation shell script automates some of the tasks in configuring `/etc/hosts`, `/etc/printcap`, and in creating the spool directory for BSD UNIX, and in running `lpadmin` command for System V UNIX.

Preparation

The installation shell script can be used on the following three kinds of the workstations. Do not use this installation shell script with other types of workstations.

- Solaris 2.5.1, 2.6, 7, 8
- HP-UX 8.x, 9.x, 10.x, 11.0
- Red Hat Linux 6.2

When you use NIS (Network Information Service) or DNS, you should configure the server before running this installation shell script.

For more information about the configuration utility of your OS, see the manual that came with the utility.

Assigning the IP Address

Preparation

Configure the printer to use the TCP/IP protocol.

- Confirm that the TCP/IP protocol on the printer is set to be active. (The factory default is active.)
- Assign an IP address to the printer and configure the other settings required for using the TCP/IP protocol.

Reference

For more information about how to make above settings, see the Setup Guide that comes with the printer.

Confirming the IP address

Follow the procedure below to confirm that the IP address has been configured correctly.

- Following procedure uses sample IP address: 192.168.15.16.

1 Enter the following:

```
# ping 192.168.15.16
```

If the address has been configured correctly, the following message appears.

```
192.168.15.16 is alive
```

If the address has been configured incorrectly, the following message appears.

```
no answer from 192.168.15.16
```

Note

- When you use NIS, the IP address and host name are written to `/etc/hosts` on the master server. When you use DNS, the information is written to a data file on the name server. After writing the host name and IP address to the file, confirm the configuration by pinging the host name.

```
# ping host_name
```

- If the host name is registered with an IP address, the server can access the printer using its host name instead of its IP address.

Executing the Installation Shell Script

After having configured the printer IP address, follow the procedure below to execute the installation shell script and set up the workstation printing environment.

Preparation

Before executing the installation shell script, the IP address, the host name and the printer name must be required.

Following procedures use sample IP address: 192.168.15.16, sample host name: `nphost` and sample printer name: `np`.

Note

- Use `ftp` to get the installation shell script from the printer.

1 Log on to the workstation as root.

Note

- If you do not log on as root, the installation shell script will not run.

2 Get the installation shell script from the printer.

- 1 Move to the directory you want to copy the installation shell script to.
- 2 Use ftp to connect to the printer with the IP address that you just configured.

```
# ftp 192.168.15.16
Connected to 192.168.15.16
220 printer FTP server ready.
name (192.168.15.16:root:)
```

- 3 When a user name is requested, ignore and press the **[RETURN]** key.

```
331 Password required for root.
Password:
```

- 4 When a password is requested, ignore and press the **[RETURN]** key.

```
230 User root logged in.
ftp>
```

- 5 Type the following to get the installation shell script.

```
ftp> get install
```

- 6 Close the ftp session.

```
ftp> bye
221 Goodbye.
#
```

3 Run the installation shell script.

```
# sh ./install
```

 **Note**

- Insert a period and slash before the current directory.

4 Enter a number to select the workstation OS that you are using.

```
Network printer install shell
Copyright RICOH CO.,LTD. 1994-2000
Select your workstation OS type.
1. SunOS 4.x.x
2. Solaris 2.x, Solaris 7-8 (SunOS5.x)
3. HP-UX 8.x,9.x,10.x,11.x
4. UnixWare
5. Linux
6. other
```

```
Enter <1-6>:
```

```
2
```

 **Note**

- SunOS and UnixWare appear on the screen, but they are not supported. Use Solaris, HP-UX or Linux.
- If you select "6", the installation shell script exits.

5 Enter the IP address of the printer.

```
Enter Printer host IP address <xxx.xxx.xxx.xxx> [return=skip]:
192.168.15.16
```

 **Note**

- The IP address will be added to the /etc/hosts file.
- If the host name of the printer has already been configured, ignore and press the **[RETURN]** key. Nothing is added to the /etc/hosts file.

6 Enter the host name of the printer.

```
Enter Printer host name : nphost
```

 **Note**

- The host name will be added to the /etc/hosts file.
- If no IP address was entered in step **5**, nothing is added to the /etc/hosts file.

7 Configure the printer name.

```
Enter logical printer name [default nphost_prn]
```

If you want to use the default name, press the **[RETURN]** key. If you want to change this name, enter a new name.

 **Note**

- The host name entered in step **6** followed by “_prn” appears in “default”.

8 Set the print option.

```
Enter remote printer name [default lp]:
```

- Press the **[RETURN]** key, print with PCL or PostScript is enabled.
- If you enter “text”, text printing is enabled.
If you enter “text”, printing with PCL and PostScript is unavailable.

```
Enter remote printer name [default lp]:text
```

 **Limitation**

- You can enter up to 14 characters for HP-UX 11.0, 256 for Solaris 8, and 51 for Red Hat Linux 6.2.

Setup with the installation shell script is finished. If you enter the IP address in step **5**, the following message appears.

```
hosts file is modified
```

9 Make a test print to confirm that the settings are correct.

```
# lpr -Pnp file_name
```

```
# lp -d np file_name
```

For more information about lpr and lp, see P.10 “Printing Method”.

Deleting the printer

To print using the `lp` or `lpr` command, the option specified when the Installation Shell Script is executed is used. Change the option in accordance with the workstation you are using.

❖ BSD UNIX workstation, Linux

Delete the printer entry from `/etc/printcap`, then execute the installation shell script again. Select options during the setup process.

Or, search the printer entry from `/etc/printcap`, change its `rp` capability to option setting.

❖ Solaris, HP-UX

Delete the printer entry, and then execute the installation shell script again. Select options during the setup process. To delete the printer entry, follow the procedure below.

① Stop the scheduler.

```
# /usr/sbin/lpshut
```

② Delete the printer.

```
# /usr/sbin/lpadmin -x printer_name
```

③ Restart the scheduler.

```
# /usr/lib/lpsched
```

Setup

The printing environment is set up automatically when the installation shell script is executed.

This section describes the set up contents when the installation shell script is executed under Red Hat Linux, Solaris and HP-UX.

Linux

❖ Adding the IP address and host name to the `/etc/hosts` file

The following line is added to the `/etc/hosts` file.

```
192.168.15.16 nphost # Network Printer
```

- **192.168.15.16** is the IP address, **nphost** is the host name, from **#** to the end of the line is a comment.

Note

- The `/etc/hosts` file contains a list of the IP addresses and their host names of all of the hosts communicating on the network. Each entry is delimited with a space or a tab, and each line is separated with a return.
- If you do not use NIS or DNS, you must manually enter the IP address and host name of each workstation using the network printer in the `/etc/hosts` file.

❖ Adding an entry to the /etc/printcap file

The following entry is added to the /etc/printcap file.

This is the configuration for printing with the lpr command. In order to use the lpr command to print, you need to edit the /etc/hosts file, add an entry for the network printer to the /etc/printcap file and create a spool directory.

```
##PRINTTOOL3## REMOTE
np|Network Printer:\
    :rm=nphost:\
    :rp=lp:\
    :sd=/var/spool/lpd/npd:\
    :lf=/var/log/npd-errs:\
    :sh:\
    :mx#0:
```

Note

- The /etc/printcap file is used to register the name and attributes of a printer. You must make an entry for the network printer in the /etc/printcap file of all workstations using the network printer.
- Each entry is separated with colons into several fields. The syntax is to begin each entry with a colon, the entry, and then end the entry with a colon, a back slash, and then a return.
- The first line of the field is the name of the printer. You use this name when logging on to a network printer from a workstation. You can define several different names by separating each name with the “|” character.
- The second, and the following lines, contain the printer's attributes. Attributes of the printer are represented by two character names referred to as capabilities. For more information about capabilities, see the following table.

Capability	Explanation	Value Required for the Network Printer.
lp	Device name of the printer	Nothing.
rm	Host name of the printer	The host name that was registered with the /etc/hosts file.
rp	Optional specification	Select options for printing. For printing with PCL or PostScript, select “lp”. For text printing, select “text”.
sd	Path name of the spool directory.	Path name of the spool directory that is to be created.
lf	Path name of the log file.	Path name of log file. For example /var/log/lpd-errs.
mx	Maximum file size which the directory can copy. When set to 0, the size is unlimited. If nothing is entered, the size is set to 1024 k.	Nothing or something suitable.

❖ Making the spool directory

Create a spool directory under `/var/spool/lpd`. The name of spool directory should be the name of the printer followed by a “d”.

Note

- ❑ The spool directory is used to control the data used for a print job. For example, when a print job is created, a temporary copy of the file data used for printing is created in the spool directory. All workstations accessing the network printer need to have a spool directory for the network printer.
- ❑ A spool directory should be made for every network printer entry listed in the `/etc/printcap` file.
- ❑ The spool directory should normally be made under `/var/spool/lpd` and the name should match that listed under the `sd` capability in `/etc/printcap`. Change the owner and group of the directory to `root` and `lp`. The following examples show how to make a `/var/spool/lpd/npd` spool directory.

```
# cd /var/spool/lpd
# mkdir npd
# chown root np
# chgrp lp np
```

❖ Making the log file

Error messages are logged to a file created in the `/var/log` directory. The log file name is the printer name followed by “d-errs”.

Solaris

❖ Adding the IP address and host name to the `/etc/hosts` file

The following line is added to the `/etc/hosts` file.

```
192.168.15.16  nphost  # Network Printer
```

- **192.168.15.16** is the IP address, **nphost** is the host name, from **#** to the end of the line is a comment.

Note

- ❑ The `/etc/hosts` file contains a list of the IP addresses and their host names of all of the hosts communicating on the network. Each entry is delimited with a space or a tab, and each line is separated with a return.
- ❑ If you do not use NIS or DNS, you must manually enter the IP address and host name of each workstation using the network printer in the `/etc/hosts` file.

❖ **Registering the printer**

The installation shell script registers the printer as a remote printer.

- ① If your workstation is Solaris 2.5.1, register the print server and print client to the print service.

```
# lpsystem -t bsd -R 0 -y "Network Printer" nphost
```

- ② Register the printer as a remote printer.

```
# lpadmin -p np -s nphost!option -T dump -I any
```

- **np** is the printer name, **nphost** is the host name. **options** is "lp" or "text". For printing with PCL or PostScript, enter "lp". For text printing, enter "text".

- ③ If your workstation is Solaris 2.5.1, set the print job enable to be accepted by print queue.

```
/usr/lib/accept np
```

- ④ If your workstation is Solaris 2.5.1, set the print job enable to print.

```
/usr/lib/enable np
```

HP-UX❖ **Adding the IP address and host name to the /etc/hosts file**

The following line is added to the /etc/hosts file.

```
192.168.15.16 np # Network Printer
```

- **192.168.15.16** is the IP address, **np** is the host name, from # to the end of the line is a comment.

 **Note**

- The /etc/hosts file contains a list of the IP addresses and their host names of all of the hosts communicating on the network. Each entry is delimited with a space or a tab, and each line is separated with a return.
- If you do not use NIS or DNS, you must manually enter the IP address and host name of each workstation using the network printer in the /etc/hosts file.

❖ **Registering the printer**

The installation shell script registers the printer as a remote printer following the procedure below.

- ① Stop the scheduler.

```
/usr/lib/lpshut
```

- ② Register the printer.

```
/usr/lib/lpadmin -Pnp -v/dev/null -mrmmodel  
-ormnphost -oroption -ob3
```

- **np** is the printer name, **nphost** is the host name. **options** is "lp" or "text". For printing with PCL or PostScript, enter "lp". For text printing, enter "text".

- ③ Set the printer so that the print job is listed in the print queue.

```
/usr/lib/accept np
```

- ④ Set the printer to perform the print job.

```
/usr/lib/enable np
```

- ⑤ Restart the scheduler.

```
/usr/lib/lpsched
```

Printing Method

1

Printing with lpr, lp

Depending on the type of the workstation being used, execute one of the following commands:

❖ BSD UNIX workstation

```
% lpr -Pprinter_name file_name [file_name...]
```

For example:

printer name is np, file names are file1 and file2

```
% lpr -Pnp file1 file2
```

❖ Solaris, HP-UX

```
% lp -d printer_name file_name [file_name...]
```

For example:

printer name is np, file names are file1 and file2

```
% lp -d np file1 file2
```

Note

- "printer_name" is the name that was entered when executing the installation shell script.
- You can use wild cards (* or ?) for the file name.
- The message "print session full" appears when the maximum number of print requests has been reached ^{*1}. You should try to print again when the number of requests becomes less than five. You can confirm the number of print requests using telnet. For more information about using telnet, see the Network Interface Board Operating Instructions provided as a PDF file on the CD-ROM labeled "Operating Instructions".

^{*1} The maximum number of print session differ depending on printer's total memory size. When the printer has standard memory (32MB), one print session is available. When the printer has optional memory (total 96MB), the maximum number of print session is five.

Printing with rsh, rcp, ftp

You can also print using the rsh, rcp and ftp commands.

Note

- Print using the format that the printer can support.
- The message “print session full” appears when the maximum number of print requests has been reached ^{*1}. You should try to print again when the number of requests becomes less than five. You can confirm the number of print requests using telnet. For more information about using telnet, see Network Interface Board Operating Instructions provided as a PDF file on the CD-ROM labeled “Operating Instructions”.

^{*1} The maximum number of print session differs depending on printer's total memory size. When the printer has standard memory (32MB), one print session is available. When the printer has optional memory (total 96MB), the maximum number of print sessions available is five.

rsh

```
% rsh host_name print < file_name [file_name...]
```

For example:

host name is nphost, file names are file1 and file2

```
% rsh nphost print < file1 file2
```

Note

- “host_name” is the name entered when executing the installation shell script.
- If you use a HP-UX, use the remsh command instead of rsh.

rcp

◆ To specify the file and print it

```
% rcp file_name [file_name...] host_name:
```

For example:

host name is nphost, file names are file1 and file2

```
% rcp file1 file2 nphost
```

◆ To print all of the files in a directory

```
% rcp -r directory_name host_name:
```

For example:

host name is nphost, directory name is directory1

```
% rcp -r directory1 nphost
```

Note

- “host_name” is the name entered when executing the installation shell script.
- You can use wild cards (* or ?) for the file name.

ftp

Depending on the number of files to be printed, use the put or mput commands.

 **Limitation**

- File names cannot contain “=” or “,”.

 **To print one file**

```
ftp> put file_name
```

 **To print several files**

```
ftp> mput file_name [file_name...]
```

 **Note**

- You can use wild cards (* or ?) for the file name with the mput command.

The following procedure shows an example of how to print a file using ftp.

1 Start ftp using the IP address or host name of the printer.

```
% ftp IP_address
```

 **Note**

- “host_name” is the name entered when executing the installation shell script.

2 Enter the user name. Ignore the password, and then press the [RETURN] key.

```
Name:
```

```
Password:
```

3 Set the file transfer mode to binary.

```
ftp> bin
```

 **Note**

- If the file transfer mode is not set to binary, the image might not be printed correctly.

4 Print the file. **Note**

- For example, to print one file named file1:

```
ftp> put file1
```

- For example, to print two files named file1 and file2:

```
ftp> mput file1 file2
```

5 Exit ftp.

```
ftp> bye
```

Printer Status

You can use the following commands to have information and the printer status displayed or copied to a file.

Use the `lpq` or `lp` command to display the status of the printer or information about print jobs.

Use the `rsh`, `rcp` or `ftp` commands to get more detailed information from the printer.

Viewing the Printer Status with `lpq` and `lpstat`

❖ BSD UNIX workstation, Linux

```
% lpq -Pprinter_name
For example: Printer name is np
% lpq -Pnp
```

❖ System V UNIX, Solaris, HP-UX

```
% lpstat -o printer_name
For example: Printer name is np
% lpstat -o np
```

Viewing the Printer Status with `rsh` and `ftp`

Use the `rsh` or `ftp` command to display the status of printer or information about print jobs using specified parameters.

You can use these commands for BSD and System V UNIX.

Note

❑ If your workstation is HP-UX, use the `remsh` command instead of the `rsh`.

```
% rsh host_name parameter
```

```
% ftp host_name
User user_name
password:
ftp> get parameter -
```

 **Note**

- ❑ For the user name and password input nothing, and then press the **[RETURN]** key.

Parameters that can be used with rsh, rcp and ftp:

Parameter	Information returned	Reference
status	Status of the printer. Information about print jobs.	Network Interface Board Operating Instructions provided as a PDF file on the CD-ROM labeled "Operating Instructions"
info	Information about the paper tray, output tray and printer language of the printer.	Printer Reference provided as a PDF file on the CD-ROM labeled "Operating Instructions".
prnlog	Record of the last 16 jobs printed.	Network Interface Board Operating Instructions provided as a PDF file on the CD-ROM labeled "Operating Instructions".
syslog	Record of messages about the Network Interface Board.	

Copying Information to a File

Use the rcp or ftp command to copy information about the specified parameters to a file.

You can use these commands for BSD and System V UNIX.

 **Note**

- ❑ The same parameters are used as those above.

```
% rcp host_name:parameter file_name
```

```
% ftp host_name
User: user_name
password:
ftp> get parameter file_name
```

 **Note**

- ❑ For the user name and password input nothing, and then press the **[RETURN]** key.

INDEX

B

BSD UNIX workstation
 Printing Method, 10
BSD UNIX workstation, Linux
 Deleting the printer, 5
 Printer Status, 13

C

configuration
 UNIX, 1

D

Deleting the printer, 5

F

ftp
 Printing, 12

I

installation shell script, 1, 2

N

Network Interface Board
 Operating Instructions, i

P

PostScript 3 Operating Instructions
 Supplement, i
Printer Reference, i
Printer Status, 13
Printing Method, 10
Printing with rsh, rcp, ftp, 11

R

rcp
 Printing, 11
rsh
 Printing, 11

S

Setup Guide, i
Solaris, HP-UX
 Deleting the printer, 5
 Printing Method, 10
System V UNIX, Solaris, HP-UX
 Printer Status, 13

U

UNIX, 1
UNIX Supplement, i

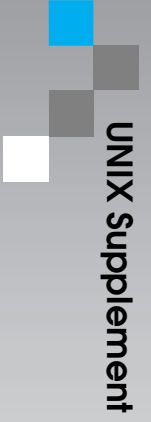

QUICK INSTALLATION GUIDE <G074-8627>

Please read the Safety Information in the Setup Guide or Printer Reference before using this machine. It contains important information related to USER SAFETY and PREVENTING MACHINE PROBLEMS.

1

WHERE TO PUT THE PRINTER

The printer's location should be carefully chosen because environmental conditions greatly affect its performance.

Warning

- Confirm that the wall outlet is near the machine and freely accessible, so that in event of an emergency, it can be unplugged easily.
- Only connect the machine to the power source described on this sheet.
- Avoid multi-wiring.
- Do not damage, break or make any modifications to the power cord. Do not place heavy objects on it, pull it hard or bend it more than necessary. These actions could cause an electric shock or fire.

Caution

- Keep the machine away from humidity and dust. A fire or an electric shock might occur.
- Place the machine on a strong and level surface. Otherwise, the machine might fall and cause personal injury.
- If you use the machine in a confined space, confirm that there is a continuous flow of air.

Optimum Environmental Conditions

Recommended temperature and humidity

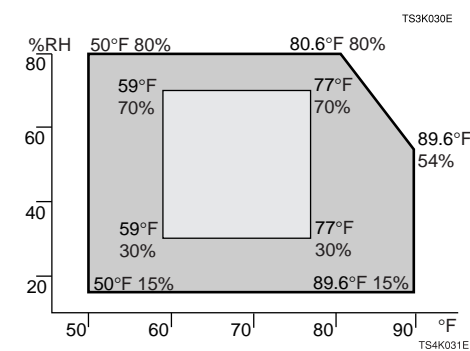
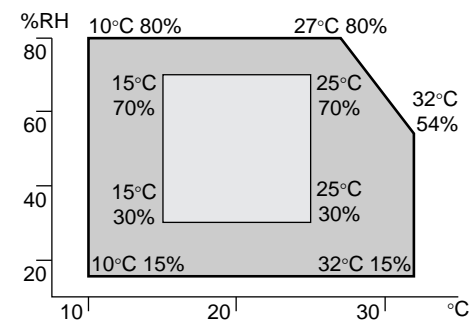

Legend: Possible operation range (shaded), Recommended range (darker shaded)

The machine must be level within 5 mm, 0.2" both front to rear and left to right.

2 Environments to Avoid

Important

- Locations exposed to direct sunlight or strong light
- Dusty areas
- Areas with corrosive gases
- Areas excessively cold, hot, or humid
- Locations near an air conditioner or humidifier
- Locations near other electronic equipment
- Locations where the printer might be subjected to frequent strong vibration

2

UNPACKING THE PRINTER AND CHECKING THE CONTENTS OF THE BOX

- 1 Check the contents of the box according to the following list. If one or some items are missing, please contact your sales or service representative.

Important

- The interface cable is not included in the box. Make sure that the interface cable you use is appropriate for your computer.

- Quick Installation Guide (this sheet)
- Setup Guide
- CD-ROM (3)
- Printer (including a starter toner cartridge)
- Additional Documentation

- 2 Remove the plastic bag. Lift the printer and move it to the place where you want to install it.

When lifting the machine, use the inset grips on both sides. Otherwise the machine could break or cause injury if dropped.

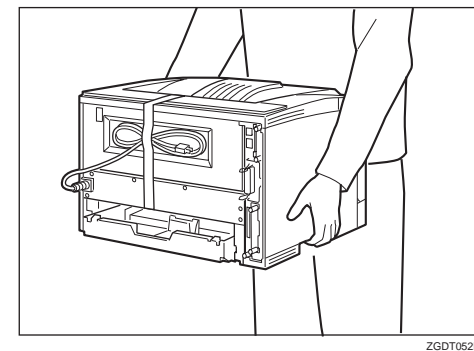

- 3 Remove the orange adhesive tape (7 pieces).

3

INSTALLING THE TONER CARTRIDGE

Warning

- Do not incinerate spilled toner or used toner. Toner dust might ignite when exposed to an open flame.
- Disposal can take place at our authorized dealer or at appropriate collection sites.
- If you dispose of the used toner cartridge yourself, dispose of them according to your local regulations.

Caution

- Do not eat or swallow toner.
- Keep toner (used or unused) and the toner cartridge out of reach of children.
- Our products are engineered to meet the highest standards of quality and functionality. When purchasing expendable supplies, we recommend using only those provided by an authorized dealer.

Important

- Do not expose the toner cartridge to a light for a long time. If you do, the toner cartridge will be damaged and the print quality might be reduced.

- 1 Open the front cover by pushing the front cover release button.

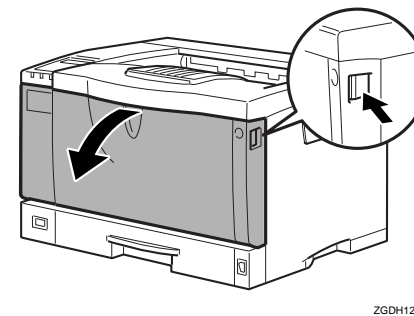

- 2 Remove the fixing material inserted between toner cartridge and the printer.

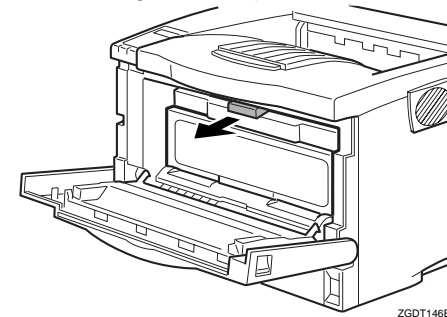

- 3 While lifting the front side of the toner cartridge, pull it out of the printer.

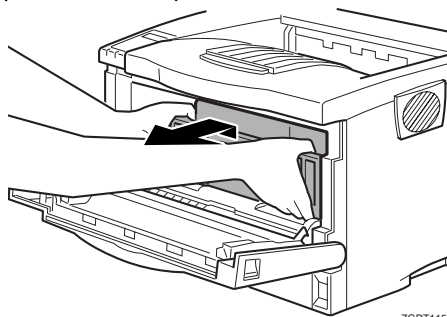

Note

- Do not hold the toner cartridge upside down or stand it vertically.
- Do not put the toner cartridge on an unstable or tilted surface.

4

INSTALLING THE PAPER TRAY

The default paper settings size are as follows:
Metric version: A4 (long-edge feed)
Inch version: 8 1/2" x 11" (long-edge feed)

For settings other than the default paper size, see "Loading Paper and Other Media" in the Printer Reference provided as a PDF file on the CD-ROM labeled "Operating Instructions".

For more information about the paper sizes that can be set in the paper tray, see "Paper and Other Media Supported by this Printer" in the Printer Reference provided as a PDF file on the CD-ROM labeled "Operating Instructions".

- 1 Lift the paper tray slightly then pull it out until it stops.

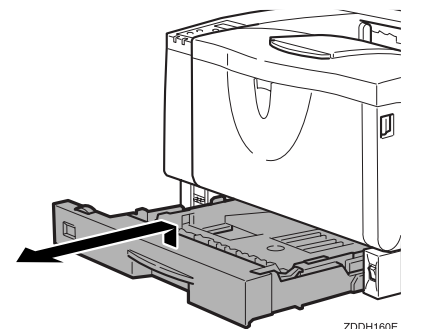

Note

- Do not touch the three white pins on the left front side of the printer.

- 2 While lifting the front side of the tray, pull it out of the printer.

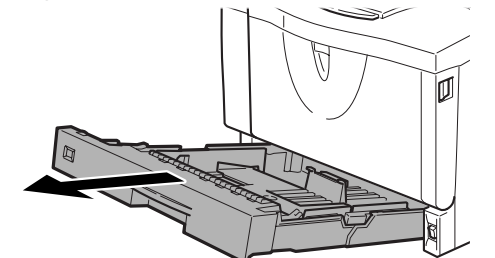

- 3 Load paper into the paper tray with the print side up.

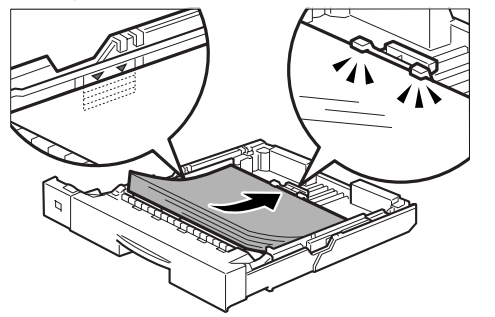

Important

- Confirm that the top of the stack is not higher than the limit mark inside the tray.
- Confirm that the paper fits under the rear guide.

- 4 Place the toner cartridge on a flat surface. Pull out the tape inside the unit horizontally while holding the cartridge with one hand as shown in the illustration.

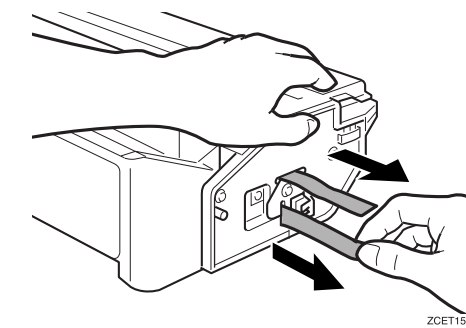

Important

- Be sure to remove the tape completely before installing the toner cartridge. Otherwise, the printer might be damaged.
- If you pull out the strips when the toner cartridge is slant or standing on its side, the cartridge might cause trouble with the printer.
- Be sure to pull the tape horizontally. Pulling it upward or downward may cause the toner to scatter.
- Be careful not to make your cloths dirty with toner.
- After pulling the tape out of the cartridge, toner scatters easily. Do not shake the cartridge.

- 5 Holding the grips of the toner cartridge, insert it into the printer until it stops.

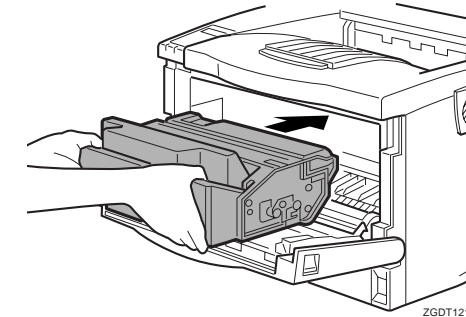

- 6 Insert the toner cartridge in its appropriate position by gently pushing down.

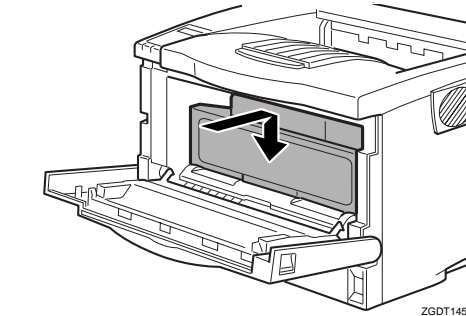

- 7 Close the front cover.

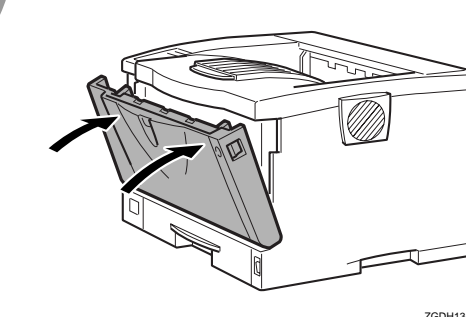

Important

- Do not close the front cover with force. If you cannot close the cover easily, pull out the toner cartridge from the printer and insert it again. After that, close the front cover again.

- 4 Carefully slide the paper tray into the printer until it stops.

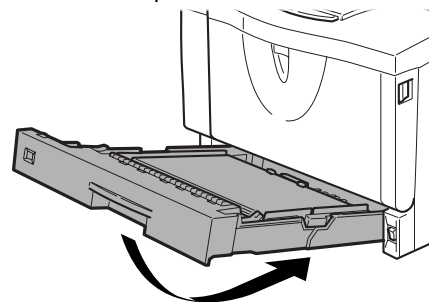

ZDDH190E

Important

- Confirm that the setting of the paper size dial matches the size and feed direction of the paper in the tray. Otherwise, the printer might be damaged or a printing problem might occur.
- Do not slide the paper tray in and out with force. If you do, the front and side paper guides will move out of the place.

5

CONNECTING THE POWER CORD

Caution

- When you pull the plug out of the socket, grip the plug to avoid damaging the cord and causing a fire or an electric shock.
- It is dangerous to handle the plug with wet hands. An electric shock might occur.

- 1 Check that the power switch is turned off.

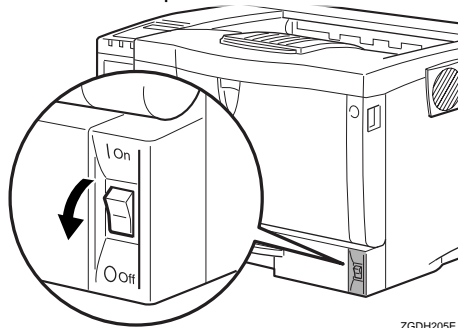

ZGDH205E

- 2 Securely insert the power cord plug into the wall socket.

6

SELECTING THE PANEL DISPLAY LANGUAGE

Select a language following the procedures described.
The message for the selected language will appear on the panel display.

Note

- The default setting is English.
- If you want to use the English panel display, the following procedures are unnecessary.

- 1 Check that the power switch is turned on.

- 2 Press the [Menu] key.

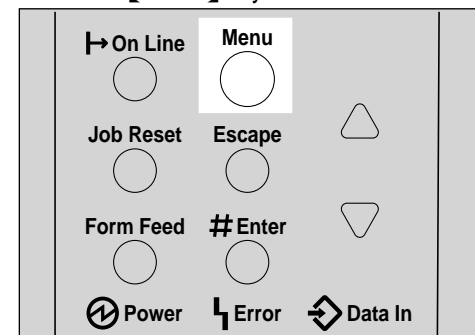

ZDSS020N

"Menu" appears on the panel display.

- 3 Press the [▲] or [▼] key until the following message appears on the panel display.



- 4 Press the [Enter #] key.

- 5 Press the [▲] or [▼] key until the language you want to select appears on the panel display.

- 6 Press the [Enter #] key.

- 7 Press the [On Line] key.
The settings are applied and the ready message appears on the panel display.

7

PRINTING A CONFIGURATION PAGE

You can check if the printer works properly by printing a configuration page.
However, you cannot check the connection between the printer and the computer by printing the configuration page.

- 1 Check that the power switch is turned on.

- 2 Press the [Menu] key.
"Menu" appears on the panel display.

- 3 Press the [▲] or [▼] key until the following message appears on the panel display.



- 4 Press the [Enter #] key.
The following message appears on the panel display.

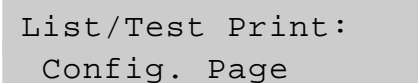

- 5 Press the [Enter #] key.
The test printing will start.

Important

- If you cannot complete the test printing correctly, check if an error message appears on the panel display. For more information about error messages, see "Troubleshooting" in the Printer Reference provided as a PDF file on the CD-ROM labeled "Operating Instructions".

8

CONNECTING THE PRINTER TO A COMPUTER

Network connection

If your printer is installed with the Network Interface Board, follow the procedures below.

- 1 Turn off the power switch.

- 2 Loop the network interface cable and attach the ferrite core.

Note

- The network interface cable loop should be about 15 cm (6") (1) from the end of the cable (on the end closest to the printer). The ferrite core at the end of the cable should be a ring type ferrite core.

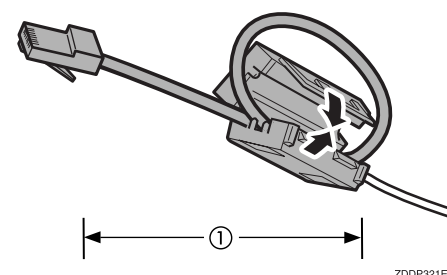

ZDDP321E

- 3 Attach the network interface cable to the jack on the board.

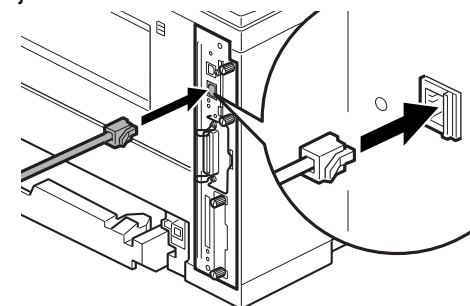

ZDDT290E

- 4 Connect the other end of the network interface cable to the network.

- 5 Turn on the power switch.
Check the LEDs on the ethernet port.

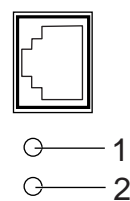

ZGDH260J

- 1 is lit when the printer is securely connected to the network.
- 2 is lit when 100BASE-TX is in use and not lit when 10BASE-T is in use.

Parallel connection

Important

- The parallel interface cable is not provided with the printer. Make sure that the interface cable you use is appropriate for your computer.
- The printer's parallel connection is a standard bi-directional interface. It requires a standard 36-pin parallel cable compliant with IEEE 1284 and an available parallel port on your computer.
- To avoid electrical interference, use a shielded cable.

Note

- Do not use a parallel cable more than 2.5 meters (8.2 feet) long.

- 1 Turn off the power switch.

- 2 Turn the computer off.

- 3 Attach the interface cable to the interface connector of the printer. Secure the cable with the metal fittings as shown in the illustration.

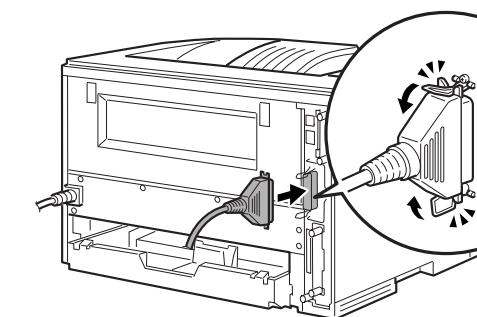

ZGDH115E

- 4 Attach the other end of the interface cable to the interface connector of the computer. Secure the cable.

Important

- Rating voltage of the parallel interface connector for the computer ; Max. DC5V.

USB connection

Important

- The USB interface cable is not provided with the printer. Make sure that the USB interface cable you use is appropriate for your computer.

- 1 Attach the USB interface cable to the USB interface connector of the printer. Secure the cable.

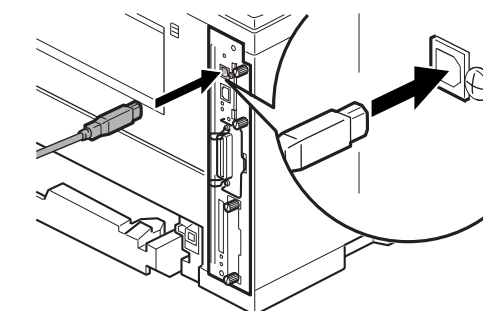

ZGD7300E

- 2 Attach the other end of the interface cable to the USB interface connector of the computer or the USB Hub. Secure the cable.

9

SETTING UP FOR PRINTING

Printing requires installation of a printer driver for the operating system.

Reference

- See "Printer Drivers for This Printer" in the Setup Guide.
- If you want to install options, see "Installing Options" in the Setup Guide.